

UNITED STATES DEPARTMENT OF THE INTERIOR

GEOLOGICAL SURVEY

Data Report For The 1985 TACT Seismic-Refraction Survey,
South-Central Alaska

by

JEFFERY M. WILSON, Patricia Meador, and Gary Fuis¹

OPEN-FILE REPORT 87-440

This report is preliminary and has not been reviewed for conformity with U.S. Geological Survey editorial standards (and stratigraphic nomenclature). Any use of trade names is for descriptive purposes only and does not imply endorsement by the U.S.G.S.

¹All at U.S.G.S. Menlo Park, California

1987

Table of Contents

	Page
Introduction	1
Aquisition of Data	1
Instrumentation and Data Reduction	4
Seismic Recorders	4
Field Operations.....	4
Data Reduction	5
Archive Tape.....	5
References Cited	6
Acknowledgements.....	6
Appendix A: Field Data Sheets and Tape Grade Scale	34
Appendix B: Archive Tape Data Format	77

Figures

1. Geologic Map Showing Tectonostratigraphic Terranes in Alaska.....	2
2. Location Map Showing Shotpoint and Recorder Locations.....	3
3. Record Sections of Shots 1 and 2 - Lake Louise Line.....	7
4. Record Sections of Shots 3 and 4 - Tok Cutoff Line.....	8
5. Record Sections of Shots 5 and 7 - Tok Cutoff Line.....	9
6. Record Section of Shot 6 - Tok Cutoff Line.....	10
7. Record Sections of Shots 8 and 9 - Tok Cutoff Line.....	11
8. Record Section of Shot 10 - Tok Cutoff Line.....	12
9. Record Section of Shot 11 - Tok Cutoff Line.....	13
10. Record Sections of Shots 12 and 13 - Montague Line.....	14
11. Record Sections of Shots 14 and 16 - Montague Line..	15
12. Record Section of Shot 15 - Montague Line.....	16
13. Record Section of Shot 17 - Montague Line.....	17
14. Record Section of Shot 18 - Montague Line.....	18
15. Record Section of Shot 19 - Cordova Peak Line.....	19
16. Record Sections of Shots 20 and 21 - Cordova Peak Line.....	20
17. Record Sections of Shots 22 and 23 - Cordova Peak Line.....	21
18. Record Sections of shots 24 and 25 - Cordova Peak Line.....	22
19. Record Section of Shot 26 - Cordova Peak Line.....	23
20. Record Section of Shot 27 - Cordova Peak Line.....	24
21. Record Section of Shot 28 - NTS-Event line.....	25
22. Schematic Diagram of Seismic Recorders	27
23. System Response Curve for Seismic Recorders	28

Tables

1. Shot Locations and Times	26
Seismic Recorder Locations	29
Lake Louise Deployment.....	29
Tok Cutoff Deployment.....	30
Montague Deployment.....	31
Cordova Peak Deployment.....	32
NTS Event Deployment.....	33

INTRODUCTION

In June, 1985, the U.S. Geological Survey conducted a seismic-refraction survey in south-central Alaska as part of the Trans-Alaska Crustal Transect (TACT) program. TACT is a multi-disciplinary investigation of the deep crust of Alaska along a corridor parallel to the Trans-Alaska Oil Pipeline from Prince William Sound to Prudhoe Bay (see Fig. 1 for location of seismic refraction and reflection surveys). Data from a 1984 seismic-refraction survey is open-filed in Daley and others, (1985), and Meador and others (1986). The 1985 data were acquired in five separate deployments (Figs. 1 and 2).

- 1 The Lake Louise deployment was located west of Glennallen on the Glenn Highway and was designed to provide near-surface velocity control for the sedimentary rocks of the Copper River basin that overlie the Peninsular terrane (Fig. 1: see Jones and others 1981 for a description of Alaskan terranes). These data also supplement the West Glenn Highway deployment of 1984.
- 2 The Tok Cutoff deployment was located east of Glennallen on the Tok Cutoff and abuts the West Glenn Highway deployment to the northeast. The data acquired through this deployment sample the deep structure of the Peninsular and Wrangellia terranes as well as the nature of their mutual contact.
- 3 The Montague deployment was located west-southwest of Cordova and the islands of Montague, Hinchinbrook, and Hawkins. This deployment was oriented parallel to strike and thus solely samples the deep structure of the Prince William terrane.
- 4 The Cordova Peak deployment was located in the Chugach Mountains east of Valdez. This deployment partially overlaps the 1984 South Richardson deployment and also extends it further to the south. The data collected investigate the across strike, deep structure of the Chugach and Prince William terrane and the nature of their boundary, the Contact Fault.
- 5 The NTS-Event deployment was located north of Glennallen on the Richardson Highway. This experiment was designed solely to record the June 12, 1985, Nevada Test Site event.

Data Acquisition

Survey Layout

A total of 27 shots (Table 1, Fig. 1), ranging in size from 245 to 1850 kg of explosive, were detonated in boreholes 0.2 x 45-70 m deep, in lakes 5-53 m deep, or in the ocean (approximately 45 m below the surface). For each

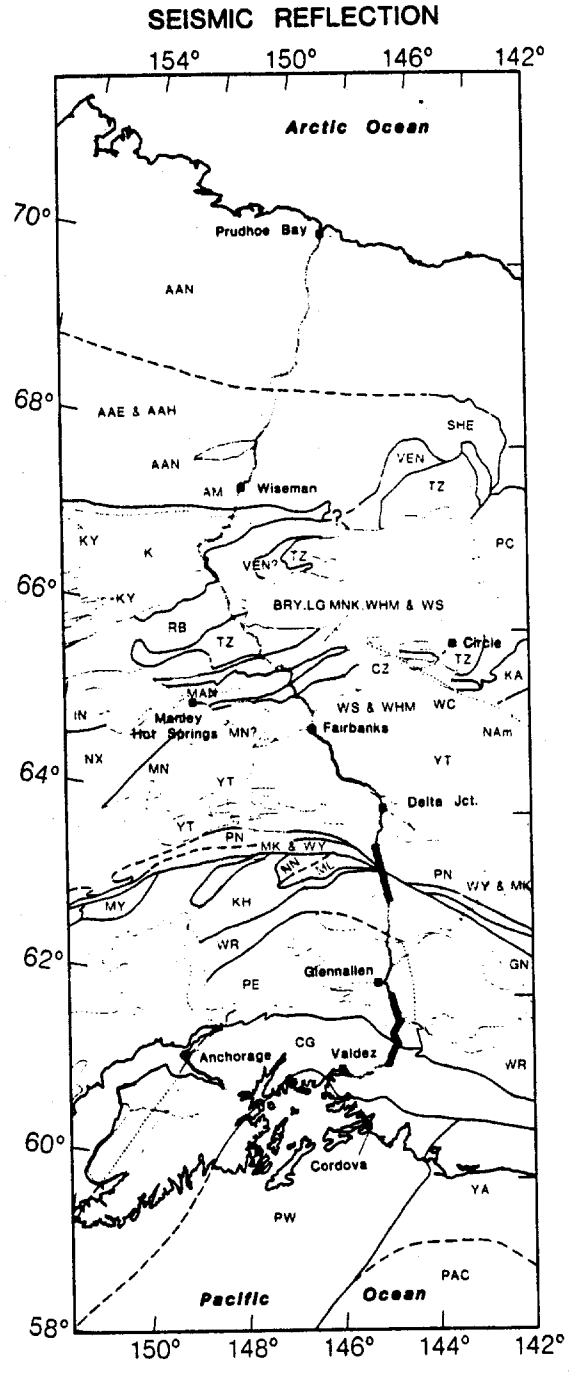
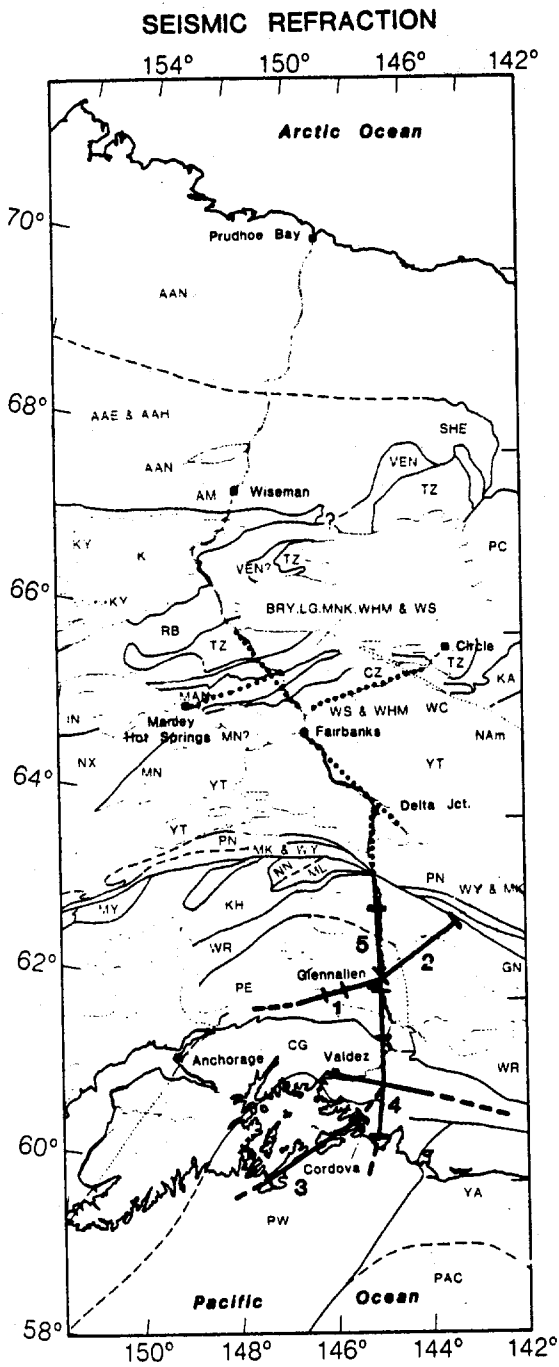

1985 Deployments **▬▬▬**
 1984 Deployments **▬▬▬**

Completed to Date **▬▬▬**

- 1 Lake Louise Deployment
- 2 Tok Cutoff Deployment
- 3 Montague Deployment
- 4 Cordova Peak Deployment
- 5 NTS Event Deployment

- Pertinent Terranes**
- CG Chugach Terrane
 - PE Penninsular Terrane
 - PW Prince William Terrane
 - WR Wrangellia Terrane

Figure 1: Map showing tectonostratigraphic terranes, completed and planned TACT seismic refraction and reflection profiles.

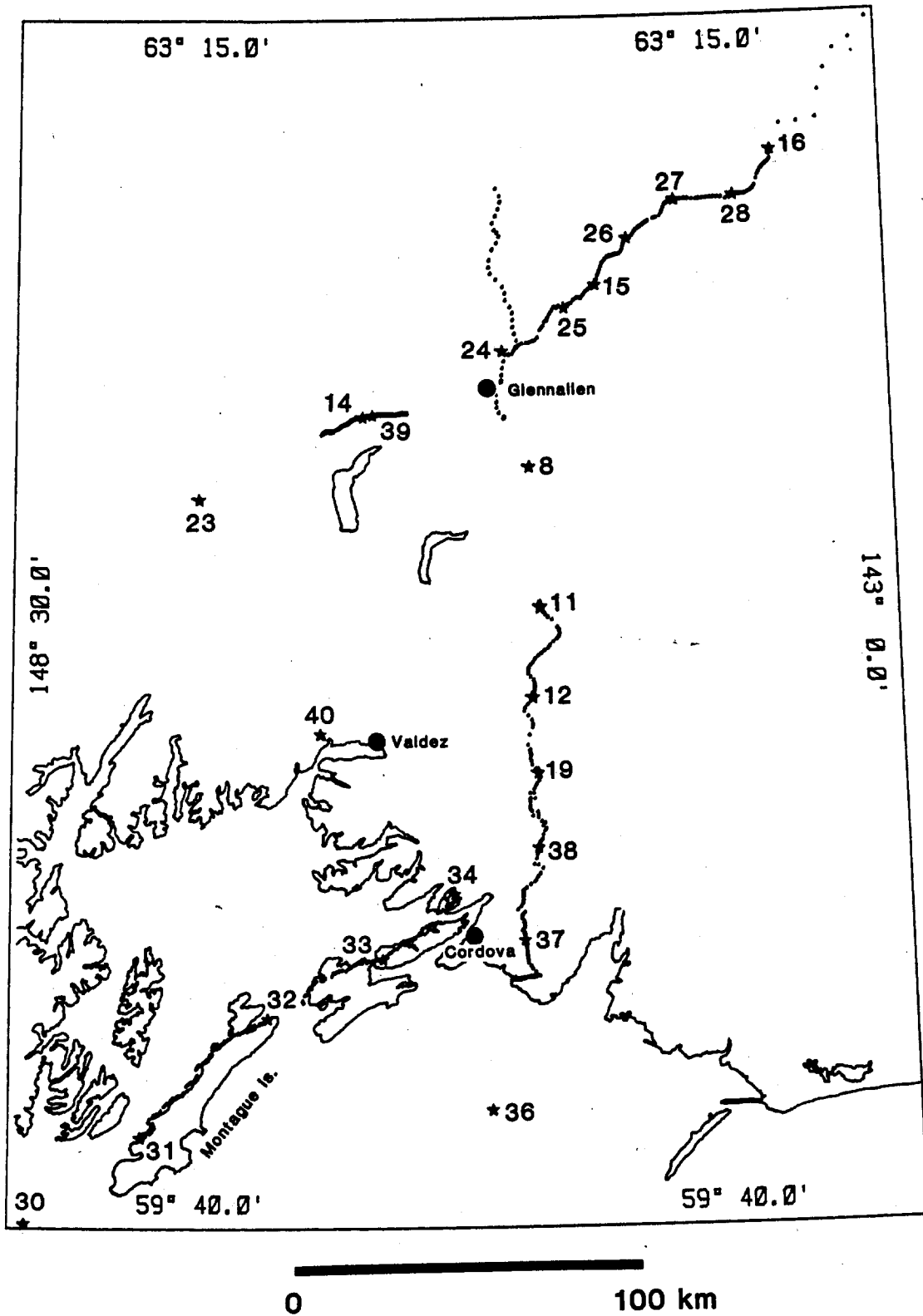

Figure 2: Recorder locations (·), Shotpoints (stars with numbers).

line, 120 instruments were deployed (Table 1, Fig. 2). The Lake Louise line, 30 km long, had an average instrument spacing of 250 m and 2 shots, shots 1 and 2. The Tok Cutoff line, 170 km long, had an average instrument spacing of 1 km for the southwestern 110 km and 10 km for the remaining 60 km. Shots 3-11 were fired into this line, including two offset shots southwest of the line, shots 6 and 10, with maximum offsets of 110 km and 50 km, respectively. For both the Lake Louise and Tok Cutoff lines instruments were deployed along highways and shots were fired in drill holes. The Montague line, 130 km long, had an average instrument spacing of 1 km except for a 12 km gap across the water gap between Hinchinbrook and Montague Islands (Hinchinbrook Entrance). Instruments were deployed exclusively by helicopter and shots 12-18 were fired exclusively in water, including one ocean shot. The shots include offset shots on either end with maximum offsets of 50 km (northeast and southwest end). The Cordova Peak line, 130 km long, had an average instrument spacing of 1 km. The north 60 km of the line was a reoccupation of the south part of the 1984 South Richardson Highway deployment. Most of the line was deployed by helicopter. The northern 4 shots (shots 19,20,23,24) were fired in drill holes and the rest in lakes or in the ocean (shots 21,22,25,26,27). Shots included 2 offset shots on the north end of the line (maximum offset (maximum offsets 45 km and 85 km) and one offset on the south end of the line (maximum offset 50 km). The NTS Event line, 45 km long, involved reoccupation of 28 sites spaced 2 km apart on the 1984 North Richardson Highway line. Three instruments with staggered recording intervals were placed at each site to maximize the chances of recording the NTS event.

Instrumentation and Data Reduction

Seismic Recorders

The seismic recorders (Healy and others, 1982) are portable, weigh approximately 18 kg, are powered by two 6-volt rechargeable batteries and contain 30-minute cassette tapes to record data. Packaged with each seismic recorder is a single vertical-component 2-Hz geophone, that is removed, oriented, and buried when the seismograph is deployed. Each recorder also includes a chronometer, three independent amplifiers with pre-set attenuation settings, a calibrator, a tape deck, and a tape-speed-compensation tone generator (Fig. 22). Ten minutes prior to the expected seismic energy arrival time, a pre-programmed microprocessor in the seismic recorder performs a geophone release test, an amplification check, and a calibration sequence consisting of a sine wave with a frequency of 10 Hz and an amplitude of 1, 10, 100, and 1000 millivolt. The response curve for the system peaks at about 20-hz (Figure 23).

Field Operations

Preparing the instruments includes synchronizing the clocks, preprogramming their microprocessors with up to 10 distinct recording times, and establishing accurate site locations. For this experiment, recorder locations were surveyed prior to deployment of seismic recorders. After the shots were fired, the seismic recorders were retrieved and, chronometer drifts were recorded.

Data Reduction

Data reduction was carried out in a field office in Cordova, Alaska. Subsequent data cleanup was performed in the office in Menlo Park, California. Data reduction involved entering shot times and locations and recorder locations and then digitizing the data for each shot on each recorder tape. Shot times are picked from a paper record on which WWVB, the master clock time code, and the detonation pulse are recorded. Shot times are generally accurate to ± 2 milliseconds. Shotpoints and recorder locations and elevations were determined with an estimated accuracy of ± 25 meters using color infrared aerial photos and 1:63,360 orthophoto and topographic quadrangle maps. The seismic signals from the cassette tapes were digitized for a total of 20 seconds at a rate of 200 samples/second (except for shot 28, the NTS event, where a total of 200 seconds at a rate of 20 samples/second were digitized; Appendix A). Digitization began at time = shot time - 2.0 sec. + distance/6.0 km/s + clock calculated drift. For offset shots, digitization began at time = shot time - (4.0 or 6.0 sec. depending on amount of offset) + distance/6.0 km/s + clock calculated drift. The record sections (Figs. 3 through 21) are plotted with maximum trace amplitudes normalized to a common value and a reducing velocity of 6.0 km/s.

ARCHIVE TAPE

These data are available on SEG-Y-format tapes recorded at 1600 BPI (Appendix A) from the following:

National Geophysical Data Center
NOAA/EGC1
325 Broadway
Boulder, CO 80303
Telephone: (303) 497-6123

References cited

- Barry, K.M., Cravers, D.A., and Kneale, C.W., (1975), Recommended standards for digital tape formats: *Geophysics* 40, 344-352.
- Daley, M.A., Ambos, E.L., and Fuis, G., (1985), Seismic Refraction Data Collected in the Chugach Mountains and along the Glenn Highway in southern Alaska in 1984: U.S. Geological Survey Open File Report USGS-OF-85-531.
- Healy, J.H., Mooney, W.D., Blank, H.R., Gettings, M.E., Kohler, W.M., Lamson, R.J., and Leone, L.E., 1982, Saudi Arabian Seismic Deep-refraction Profile: Final Project Report, U.S. Geological Survey Open-File Report USGS-OF-02-37, 429 pp.
- Jones, D.L., Silberling, N.J., Berg, H.C., and Plafker, G., 1981, Map Showing Tectonostratigraphic Terranes of Alaska, Columnar Sections, and Summary, Descriptions of Terranes: U.S. Geological Survey Open-File Report USGS-OF-81-792.
- Meador, P.J., Ambos, E.L., and Fuis, G., 1986, Data Report for the North and South Richardson Highway Profiles, TACT, Seismic-refraction Survey, southern Alaska: U.S. Geological Survey Open File Report USGS-OF-86-274.

Acknowledgements

The authors wish to express their appreciation to E. Ambos, R. Benbow, P. Berge, R. Colburn, E. Criley, C. Gilbert, E. Goodwin, M. Green, S. Johnson, R. Kaderabek, the late D. Knapp, K. La Joie, J. Lahr, A. Levander, N. MacGregor-Scott, C. Stephens, B. McClearn, W. Mooney, S. Nelson, B. Page, D. Reneau, D. Ruggery, J. Van Shaack, J. Shemeta, and J. Taber for their assistance in field work, data processing, and administration. Also special thanks to J. McCarthy for the review of this data report.

We also wish to thank numerous persons in other federal and private agencies who expediated our permitting process or actively helped in field (or ocean) work. These include L. Lau of Ahtna, Inc., R. Anderson of Airlogistics, Inc., H. Richardson and R. Legg of the Federal Aviation Administration, R. Morris of National Marine Fisheries Service, R. Yetka of Temsco, Inc., K. Kotler of U.S. Bureau of Land Management, J. Underwood and G. Trucks of the U.S. Coast Guard, F. Arbogast and L. Keeler of U.S. Forest Service, C. Budd and R. Martin of U.S. Park Service.

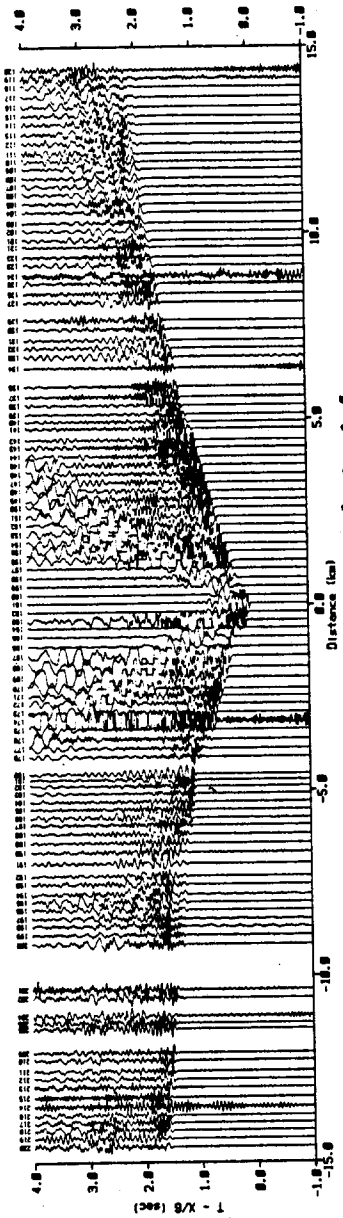

Shot 1, Shotpoint 14

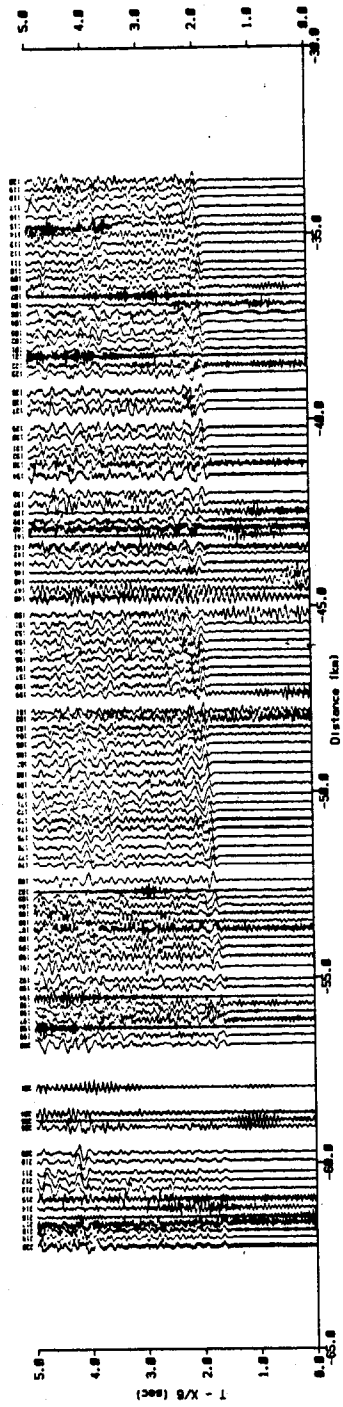

Shot 2, Shotpoint 7 (Offset)

Figure 3: Record Sections from the Lake Louise Line.

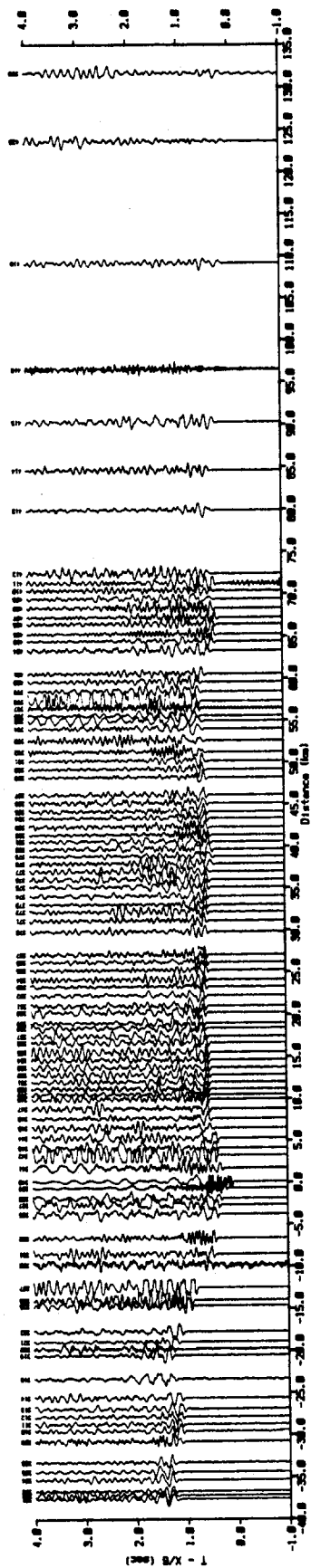

Shot 3, Shotpoint 15

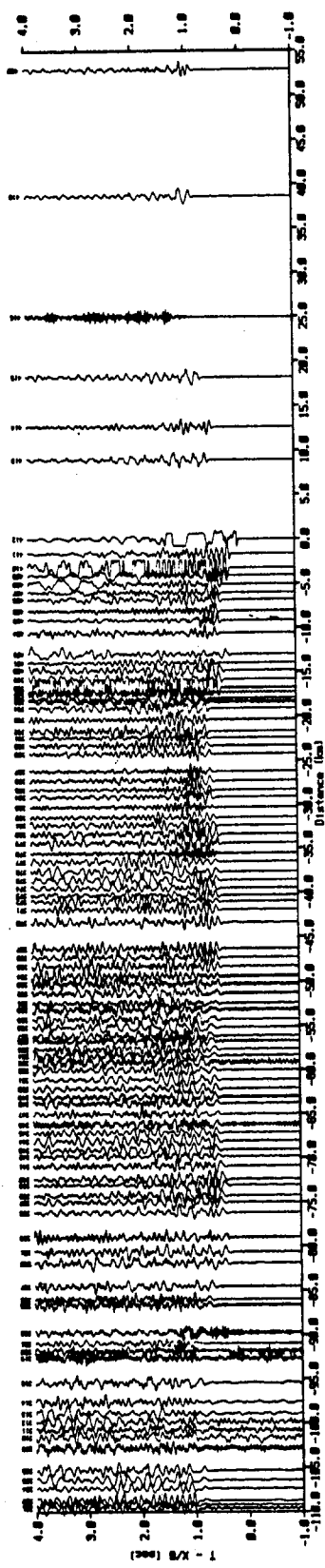

Shot 4, shotpoint 16

Figure 4: Record Sections from the Tok Cutoff Line.

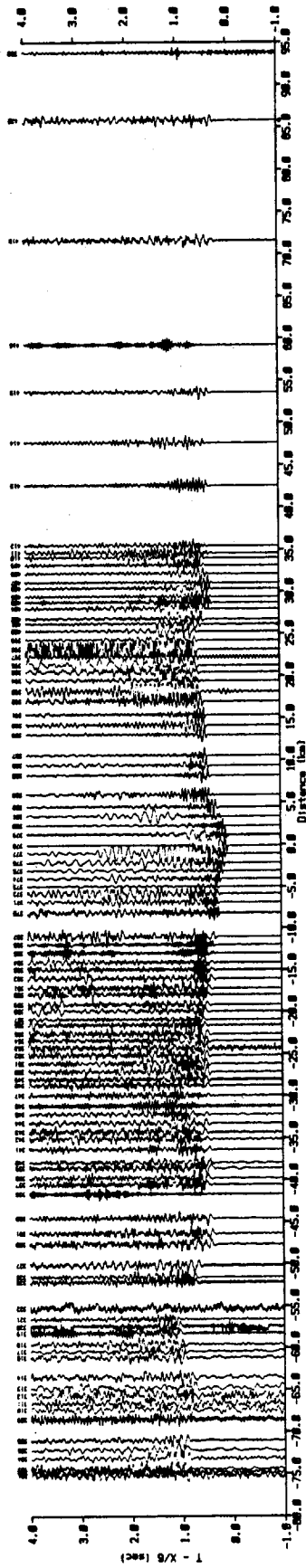

Shot 5, Shotpoint 27

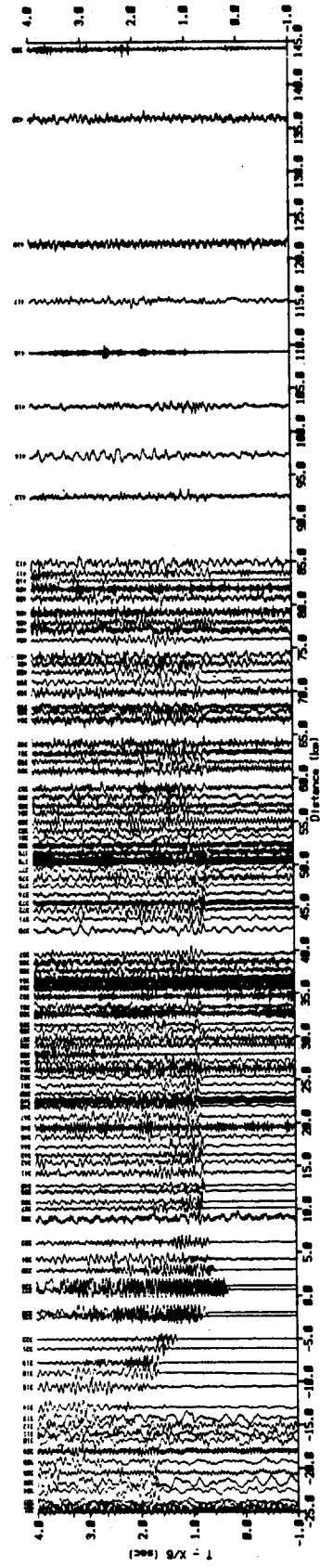

Shot 7, Shotpoint 25

Figure 5: Record Sections From the Tok Cutoff Line.

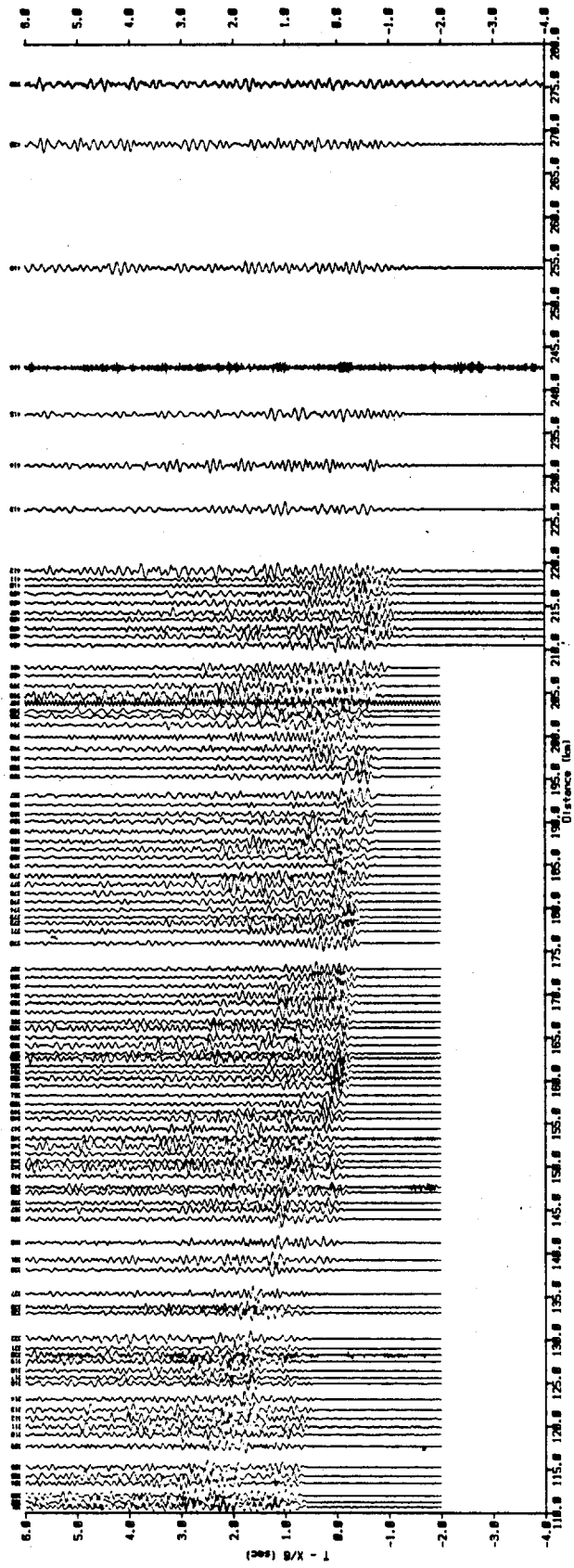

Shot 6, Shotpoint 23 (Offset)

Figure 6: Record Section from the Tok Cutoff Line.

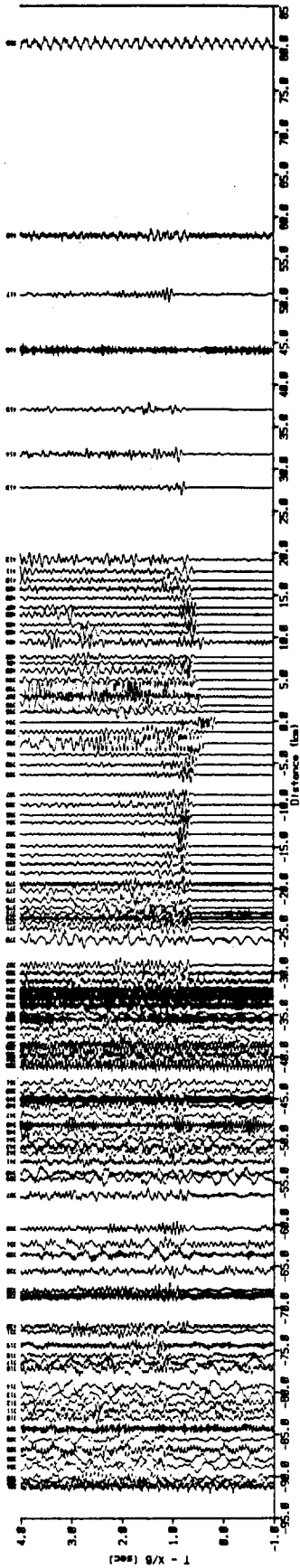

Shot 8, Shotpoint 28

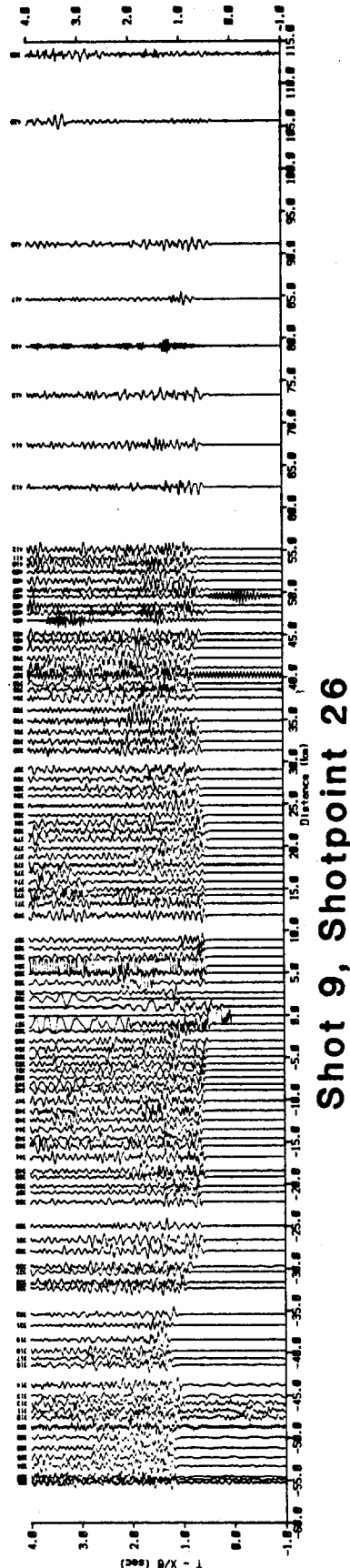

Shot 9, Shotpoint 26

Figure 7: Record Sections from the Tok Cutoff Line.

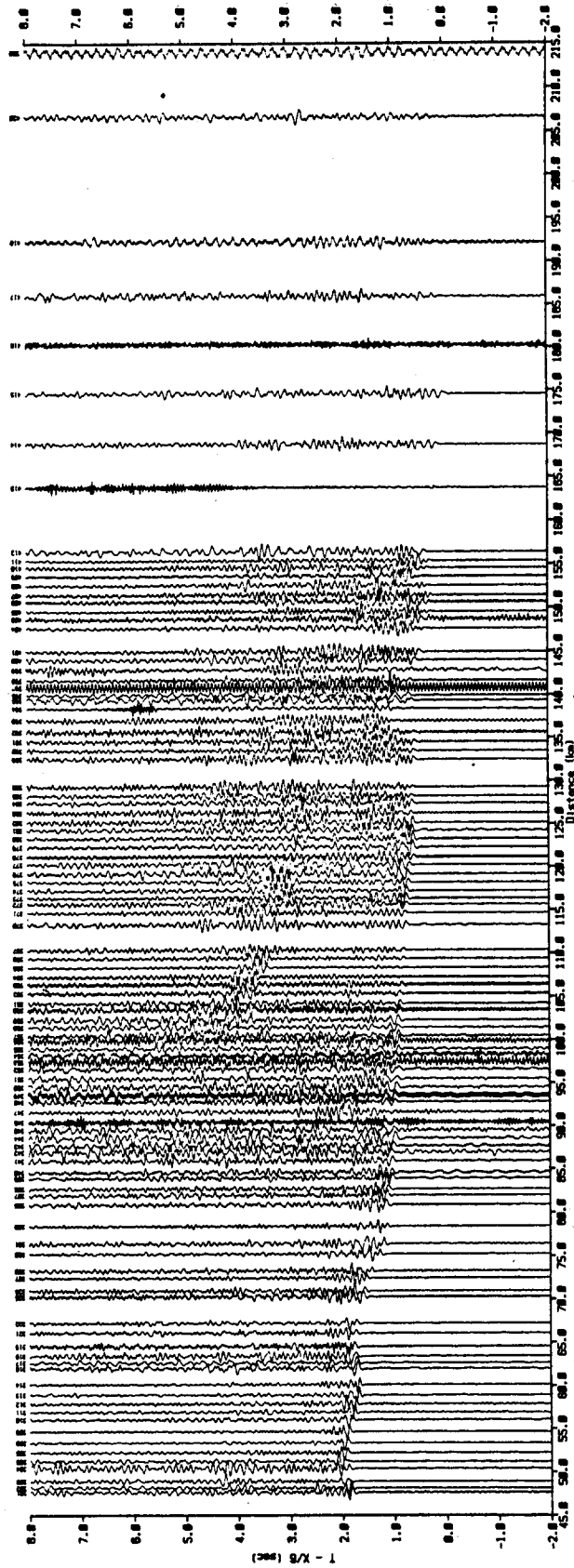

Shot 10, Shotpoint 39 (Offset)

Figure 8: Record Section from the Tok Cutoff Line.

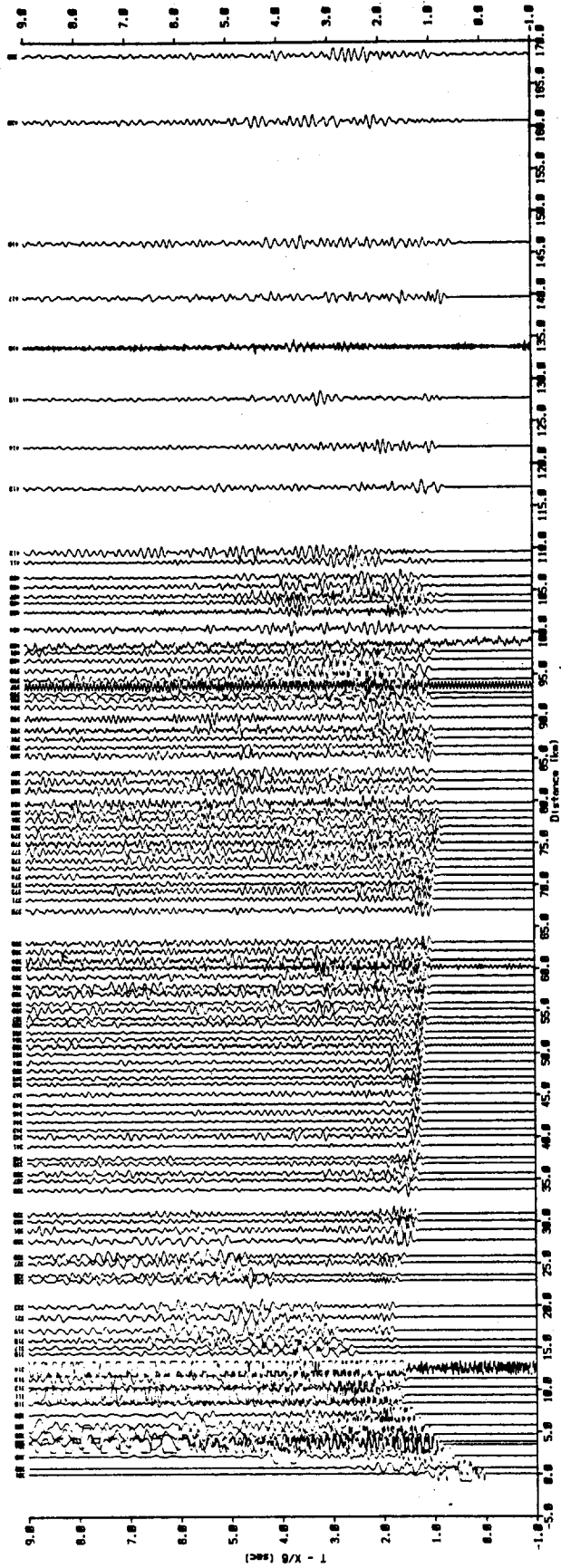

Shot 11, Shotpoint 24

Figure 9: Record Section from the Tok Cutoff Line.

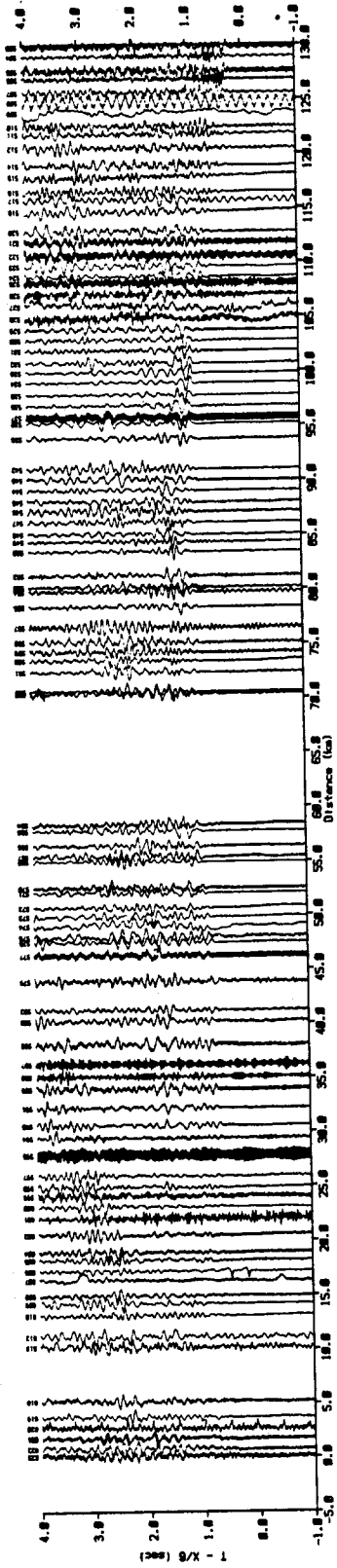

Shot 12, Shotpoint 40 (Fan)

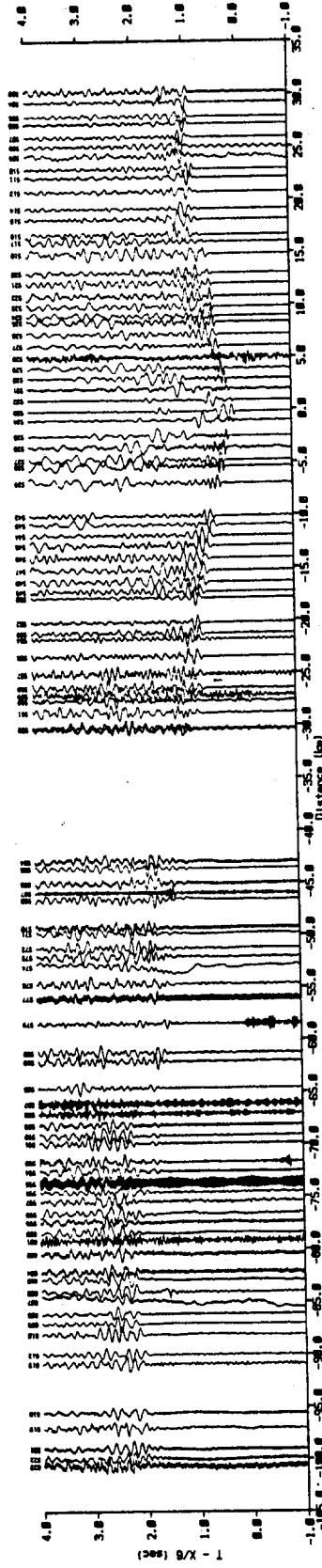

Shot 13, Shotpoint 33

Figure 10: Record Sections from the Montague Line.

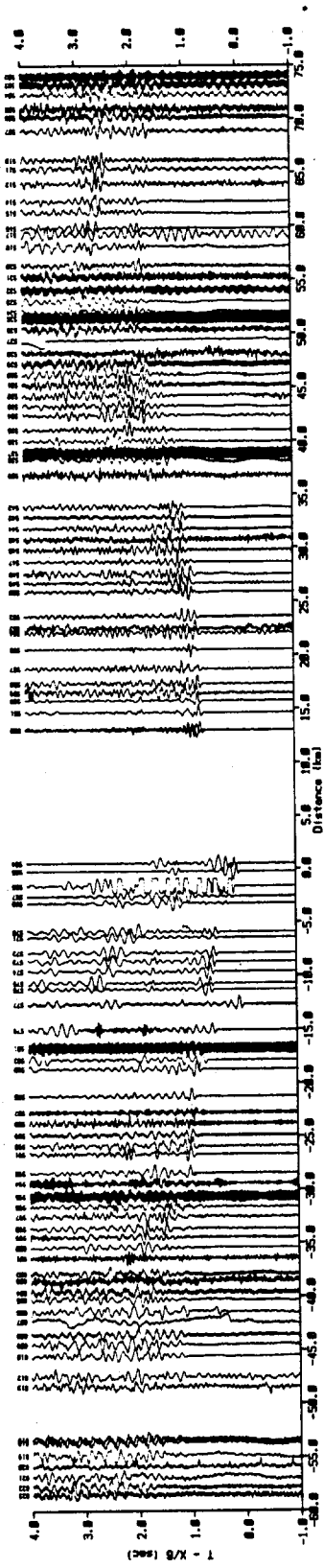

Shot 14, Shotpoint 32

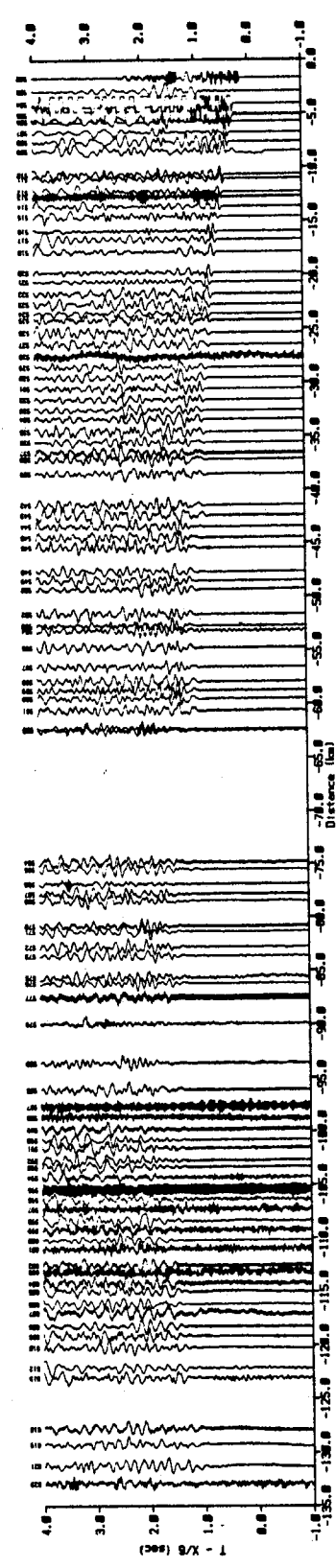

Shot 16, Shotpoint 34

Figure 11: Record Sections from the Montague Line.

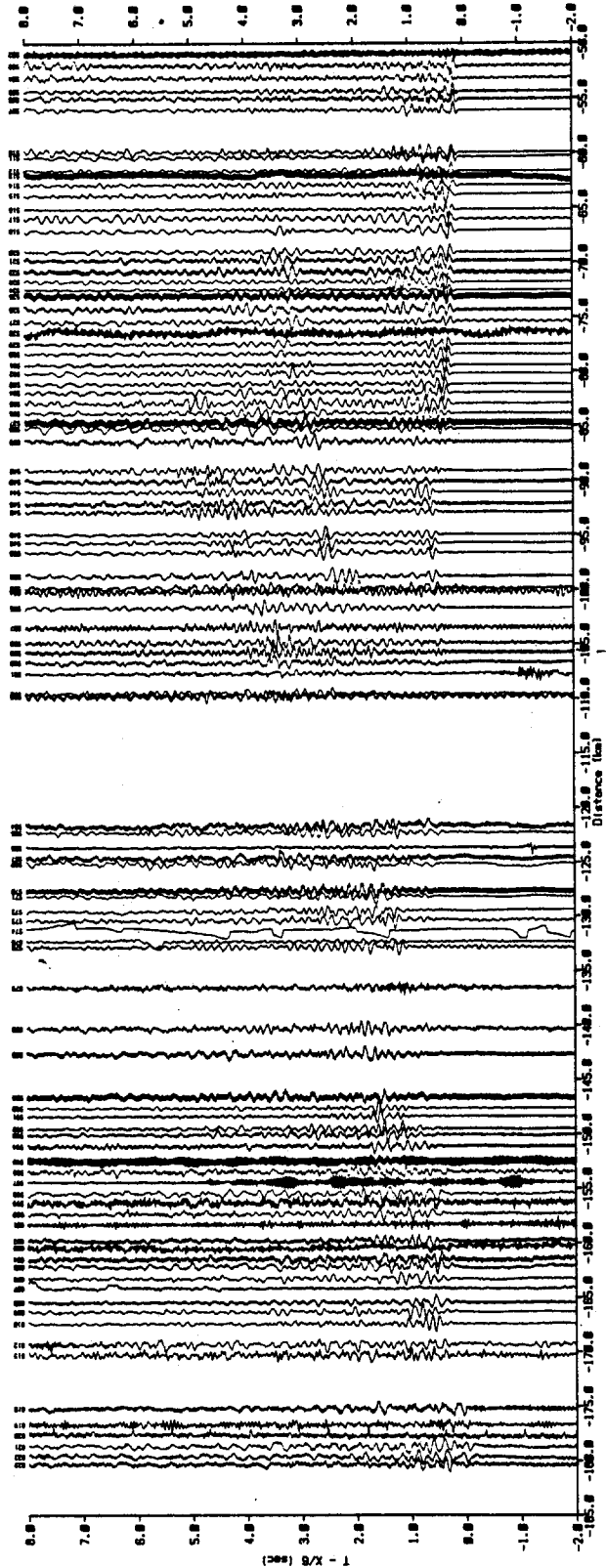

Shot 15, Shotpoint 19 (Offset)

Figure 12: Record Section from the Montague Line.

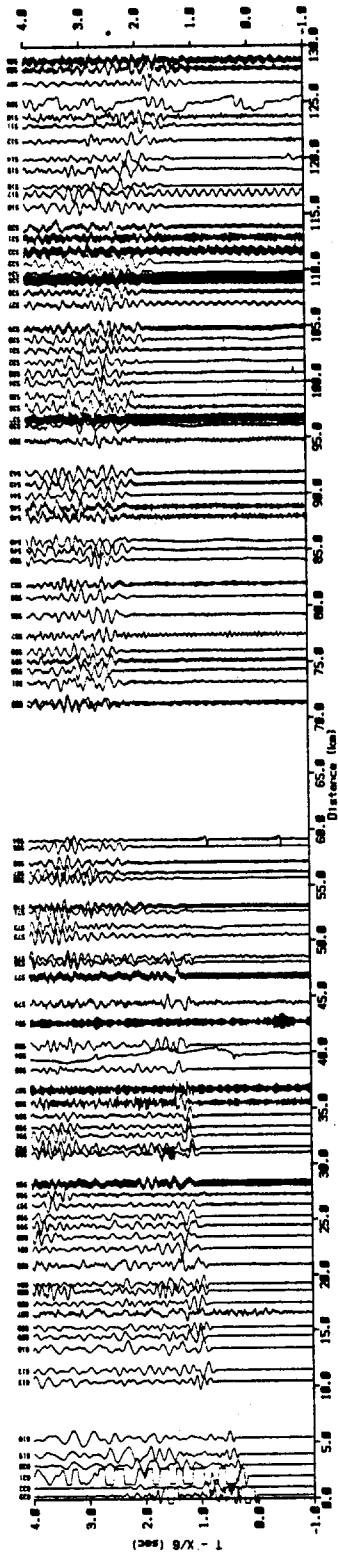

Shot 17, Shotpoint 31

Figure 13: Record Section from the Montague Line.

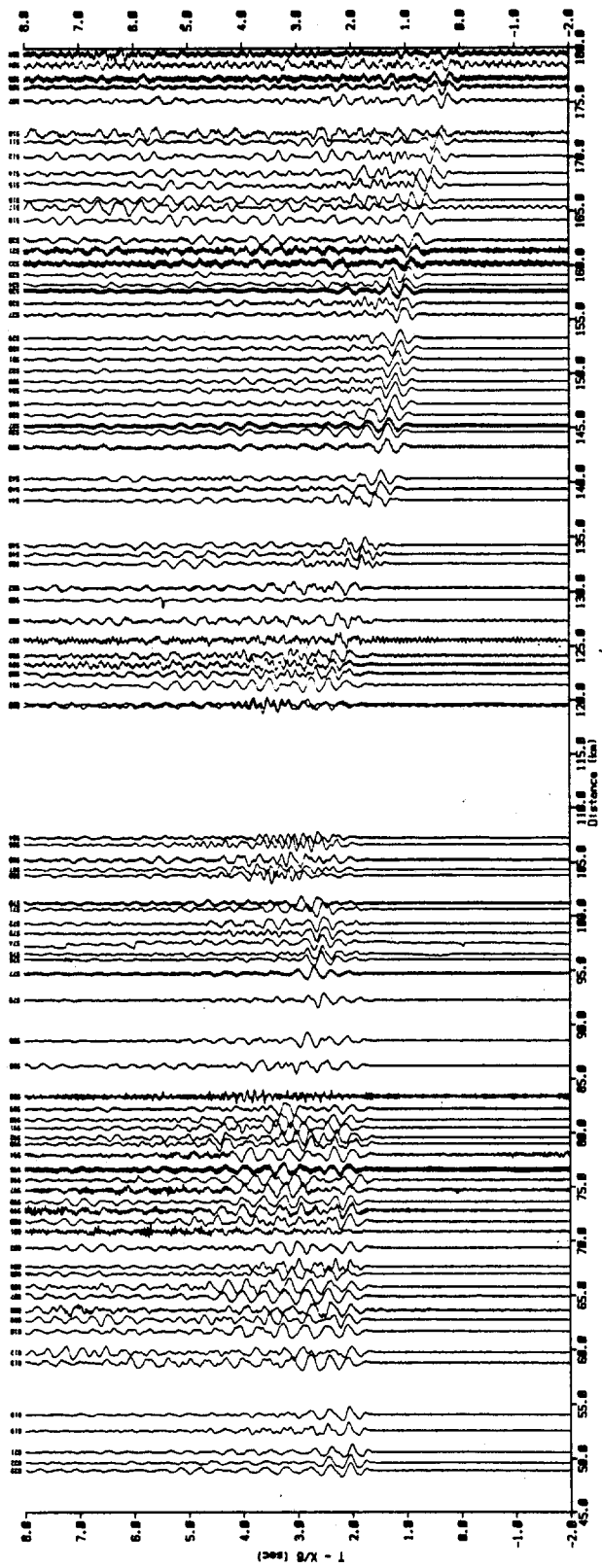

Shot 18, Shotpoint 30 (Offset)

Figure 14: Record Section from the Montague Line.

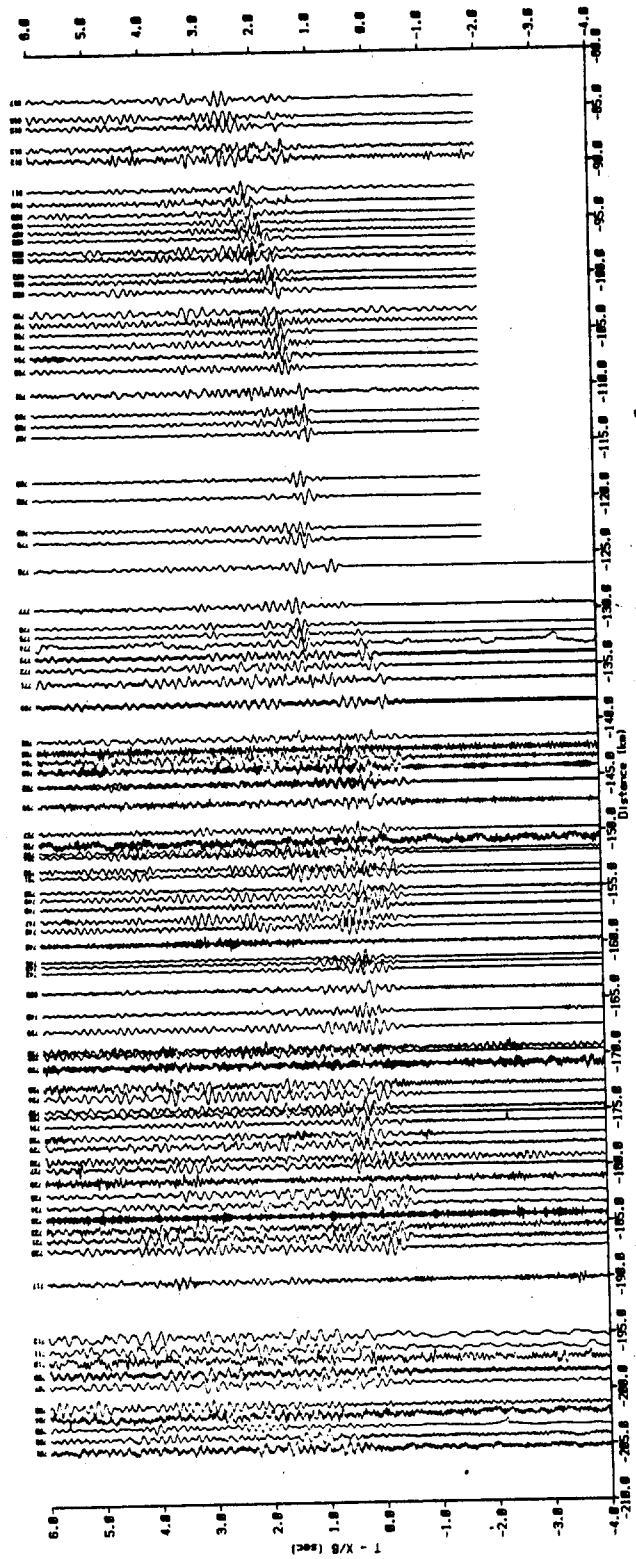

Shot 19, Shotpoint 24 (Offset)

Figure 15: Record Section from the Cordova Peak Line.

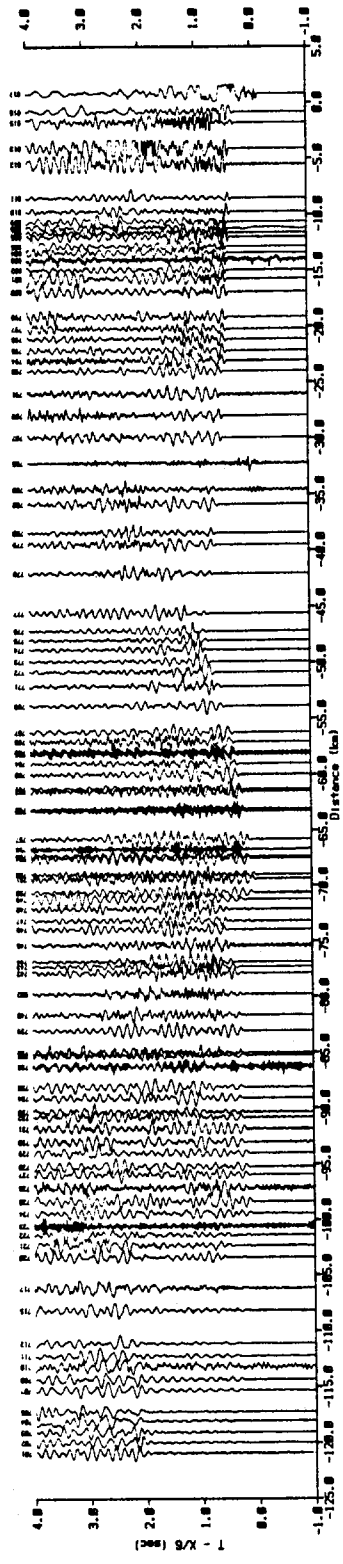

Shot 20, Shotpoint 11

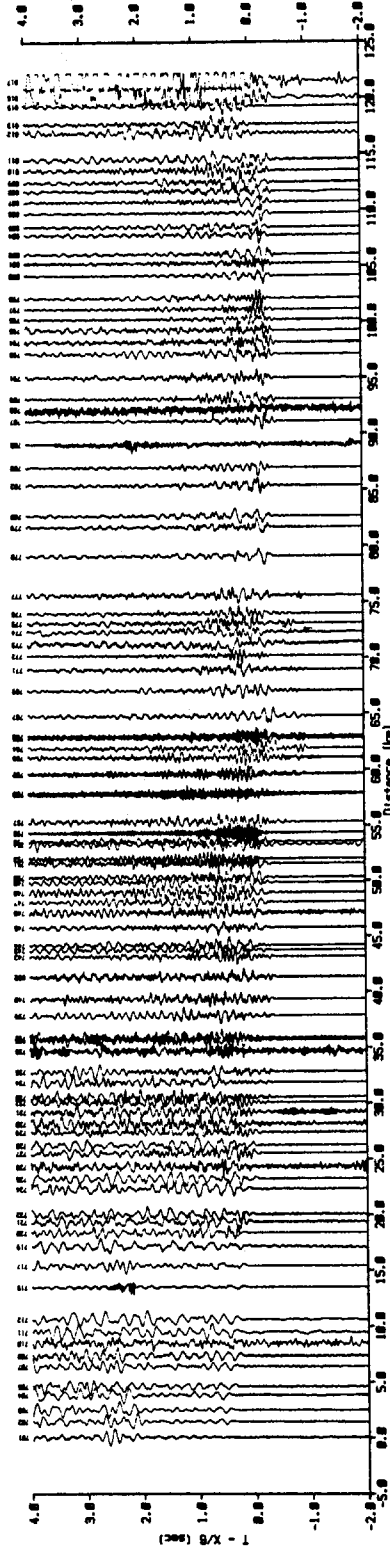

Shot 21, Shotpoint 40 (Fan)

Figure 16: Record Sections from the Cordova Peak Line.

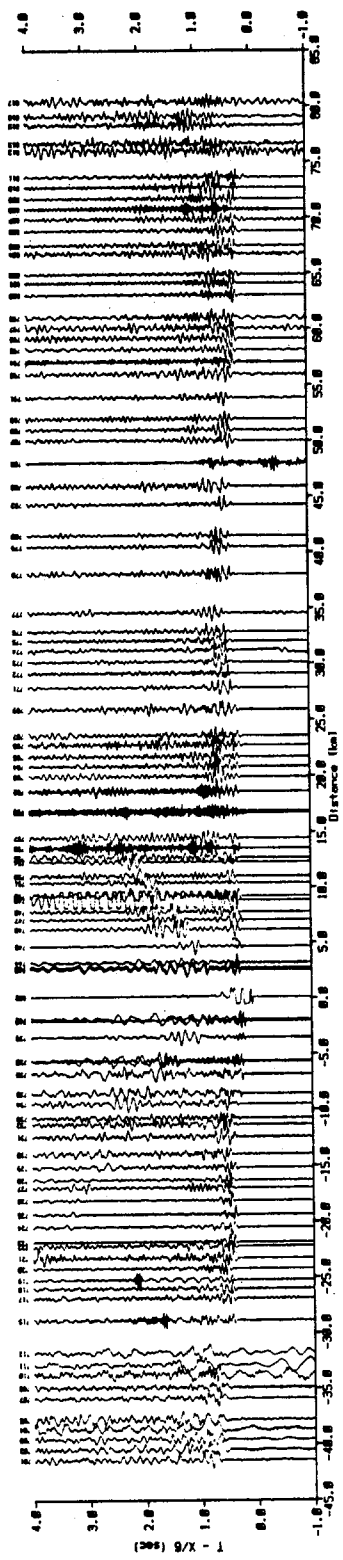

Shot 22, Shotpoint 38

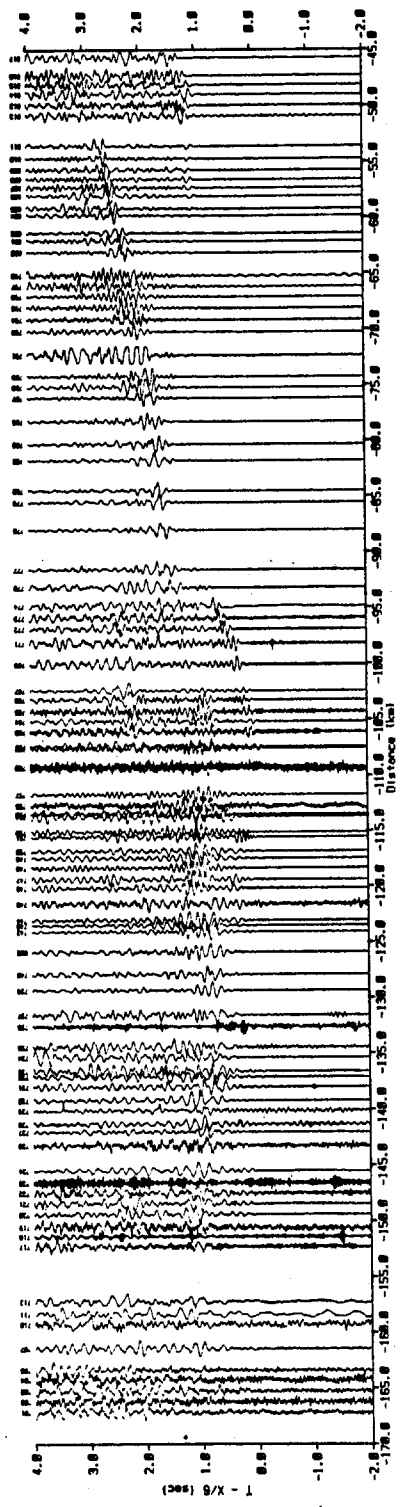

Shot 23, Shotpoint 8 (Offset)

Figure 17: Record Sections from the Cordova Peak Line.

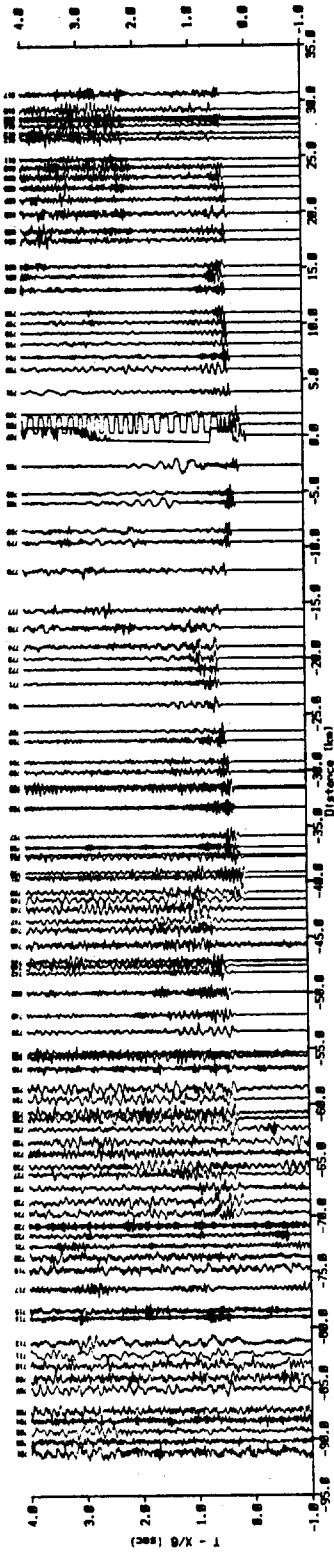

Shot 24, Shotpoint 12

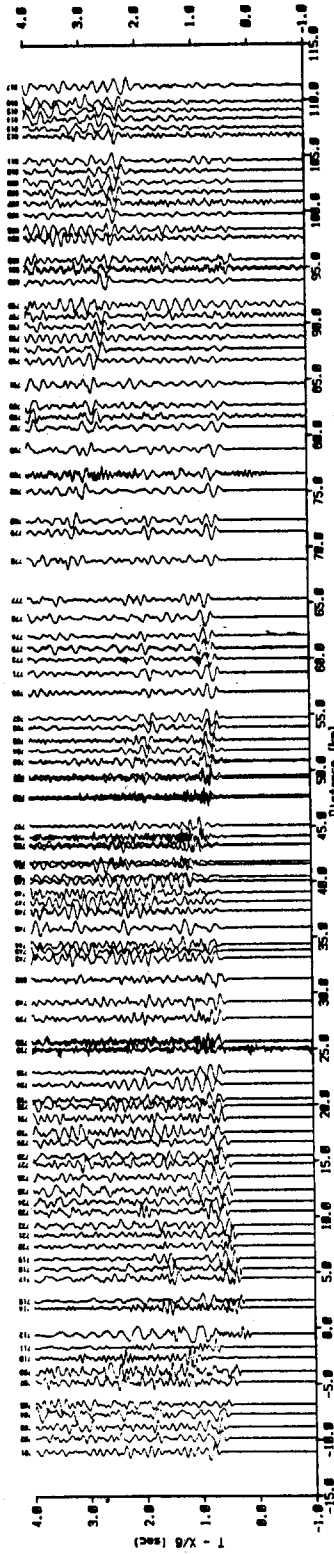

Shot 25, Shotpoint 37

Figure 18: Record Sections from the Cordova Peak Line.

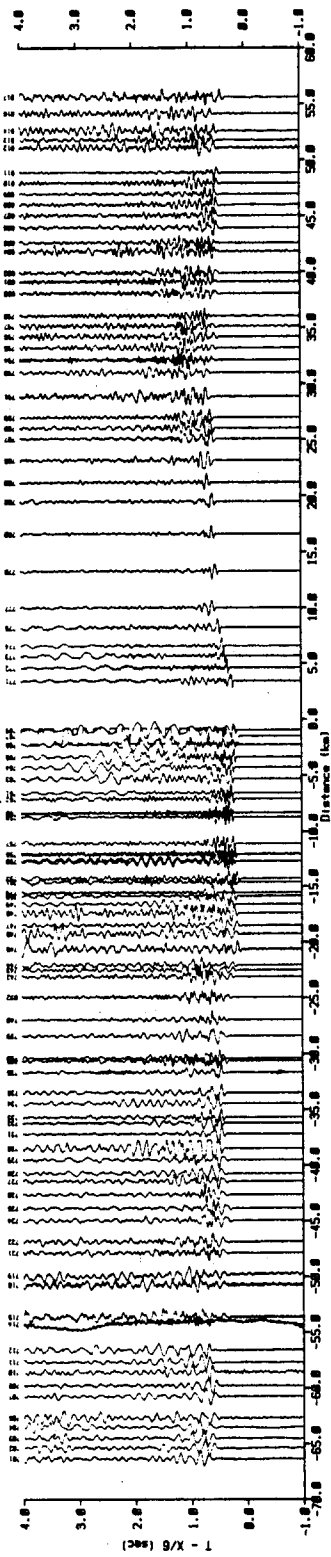

Shot 26, Shotpoint 19

Figure 19: Record Section from the Cordova Peak Line.

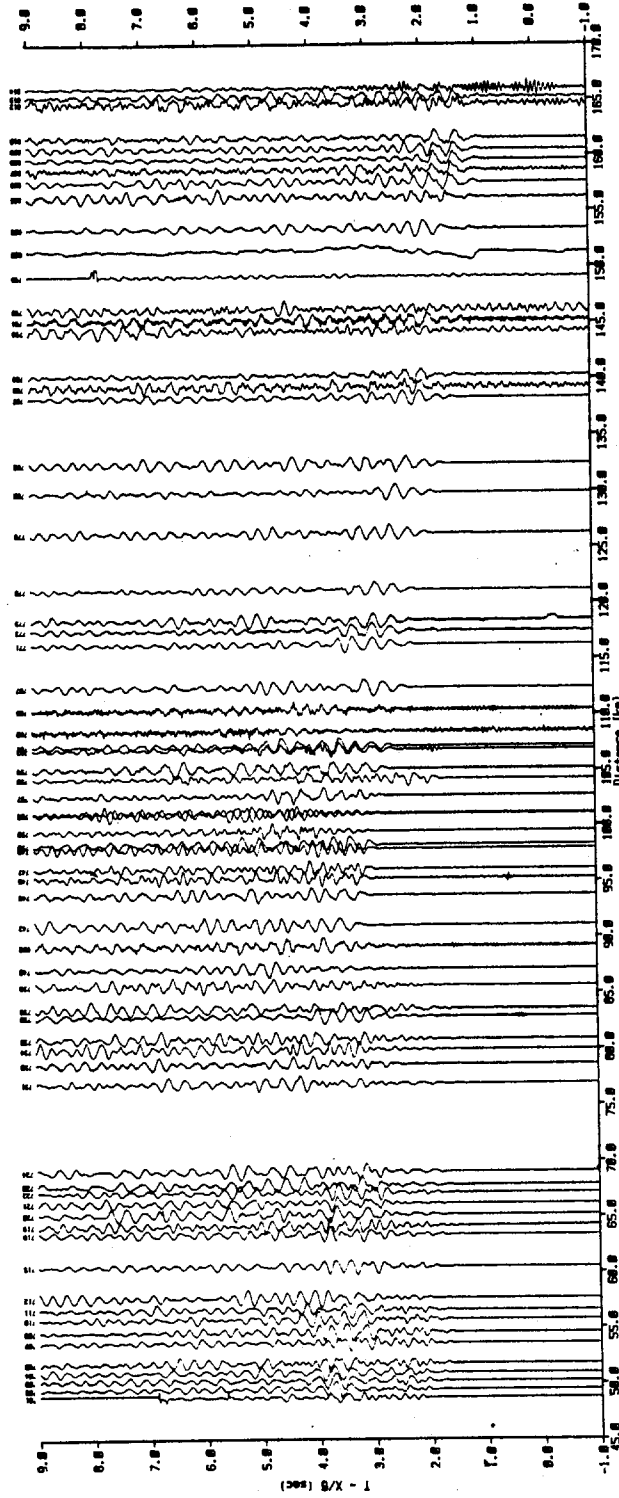

Shot 27, Shotpoint 36 (Offset)

Figure 20: Record Section from the Cordova Peak Line.

Band Pass Filtered .5-5 Hz for Display Purposes

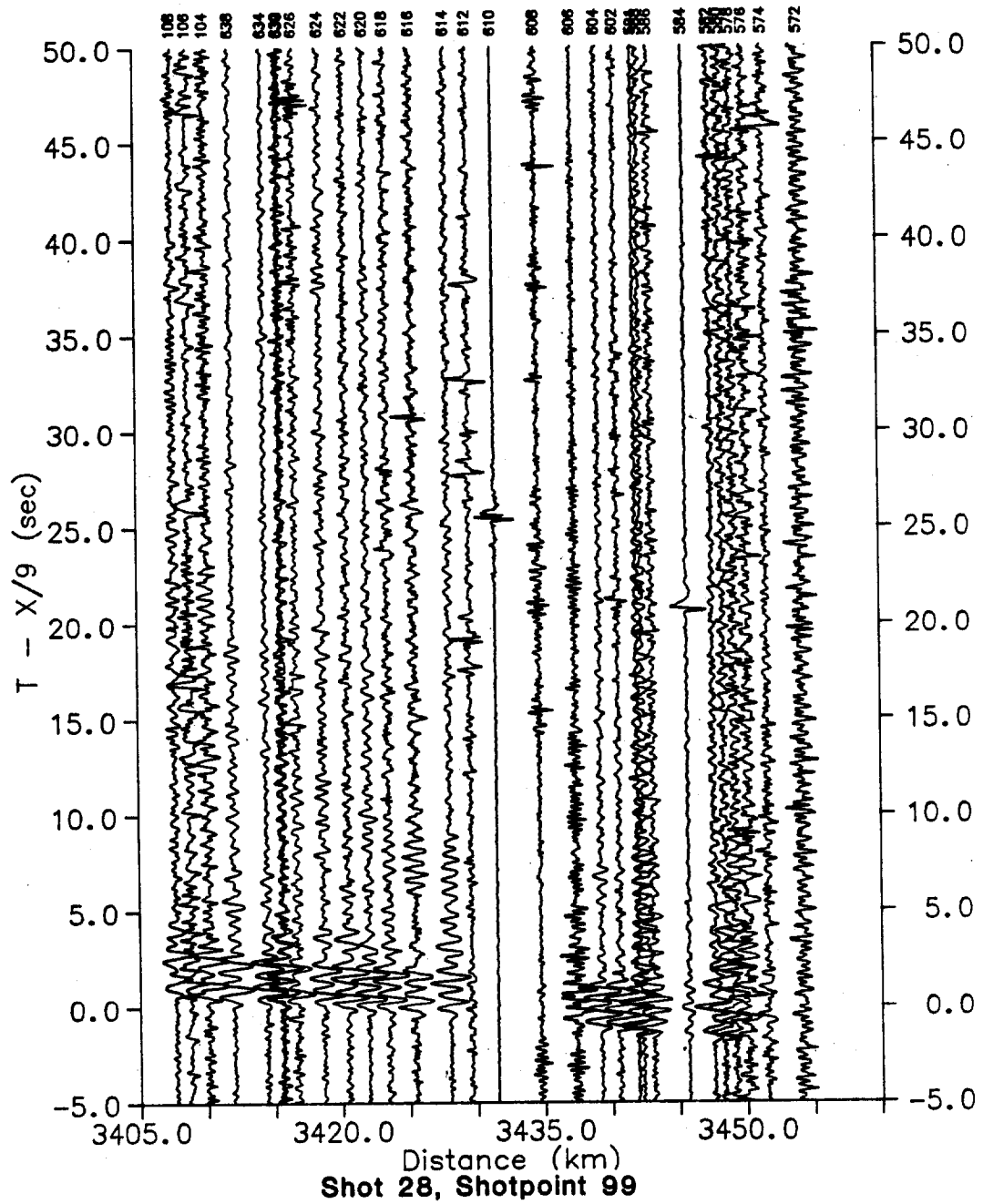
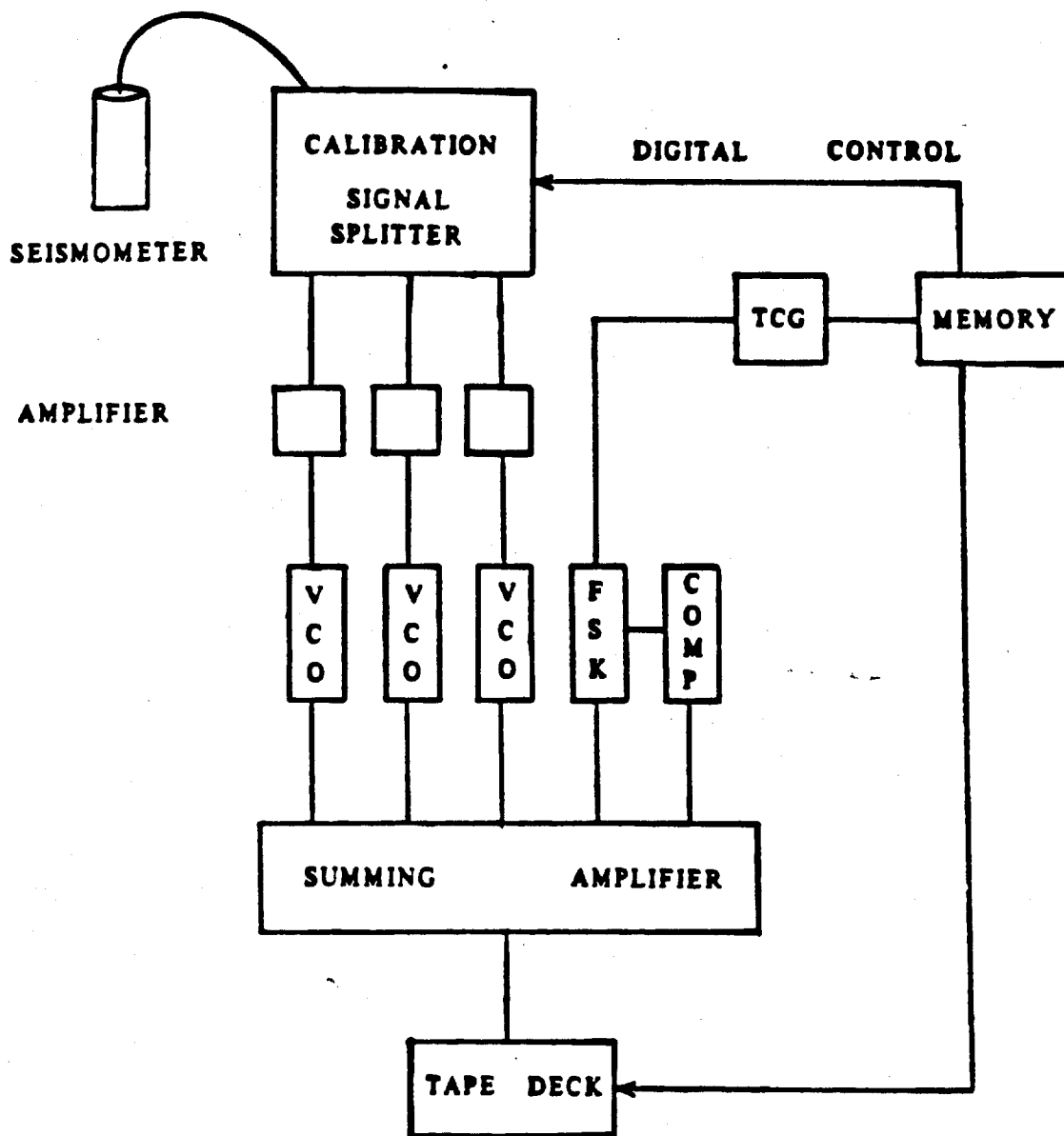

Figure 21: Record Section From NTS Event on 6-12-85

Table 1: Master Shot List. Includes the shot number, shotpoint number, date (calendar and Julian), and shot time (GMT), latitude (degrees, minutes), longitude (degrees, minutes), charge size (lbs), and notes pertaining to each shot.

Lake Louise Deployment Shots 1-2
 Tok Cutoff Deployment Shots 3-11
 Montague Deployment Shots 12-18
 Cordova Peak Deployment Shots 19-27
 NTS Event Deployment Shot 28

Shot Number	Shot Point	Date	Shot Time (Day,Hour,Min,Sec)	Latitude (deg)	Longitude (deg)	Size (lbs)	
1	14	JUN 7, 1985	159:00:30:00.012	62 5.3289	146 19.1514	540	
2	7	JUN 7, 1985	159:00:32:00.014	69 9.9417	145 24.9933	1800	
3	15	JUN 9, 1985	161:07:00:00.009	62 28.1750	144 50.2767	2040	
4	16	JUN 9, 1985	161:07:02:00.010	62 51.1855	143 41.8984	3000	(APPROX. SIZE)
5	27	JUN 9, 1985	161:07:04:00.012	62 42.8562	144 19.3936	2040	
6	23	JUN 9, 1985	161:07:06:00.008	61 50.8521	147 20.9492	4000	(APPROX. SIZE)
7	25	JUN 10, 1985	161:09:00:00.013	62 24.1877	145 2.3975	1020	
8	28	JUN 10, 1985	161:09:02:00.013	62 43.4419	143 56.7529	2000	(APPROX. SIZE)
9	26	JUN 10, 1985	161:09:04:00.012	62 36.2820	144 37.7842	1020	
10	39	JUN 10, 1985	161:09:06:00.008	62 5.6780	146 15.6182	3000	
11	24	JUN 10, 1985	161:11:00:00.010	62 16.7620	145 26.1504	3000	(APPROX. SIZE)
12	40	JUN 19, 1985	170:06:30:00.012	61 9.1948	146 35.9717	3600	
13	33	JUN 19, 1985	170:06:32:00.008	60 28.5017	146 13.8154	2000	(APPROX. SIZE)
14	32	JUN 19, 1985	170:06:34:00.008	60 17.9204	146 55.8896	2040	
15	19	JUN 19, 1985	170:10:30:00.010	61 1.8251	145 15.6821	4400	
16	34	JUN 19, 1985	170:10:32:00.008	60 40.1560	145 47.2627	2940	
17	31	JUN 19, 1985	170:10:34:00.009	59 56.4065	147 42.4258	2940	
18	30	JUN 19, 1985	170:12:32:00.018	59 40.7000	148 23.9400	540	
19	24	JUN 23, 1985	175:06:30:00.010	62 16.7620	145 26.1504	3060	
20	11	JUN 23, 1985	175:06:32:00.011	61 31.3367	145 13.6217	3000	(APPROX. SIZE)
21	40	JUN 23, 1985	175:06:34:00.009	61 9.1948	146 35.9717	3600	
22	38	JUN 23, 1985	175:06:36:00.016	60 48.3828	145 16.0215	2040	
23	8	JUN 24, 1985	175:10:30:00.009	61 56.3300	145 16.7483	4080	
24	12	JUN 24, 1985	175:10:32:00.014	61 15.3000	145 17.1100	2040	
25	37	JUN 24, 1985	175:10:36:00.016	60 31.7795	145 21.7637	3000	(APPROX. SIZE)
26	19	JUN 24, 1985	176:06:30:00.009	61 1.8251	145 15.6821	2040	
27	36	JUN 25, 1985	176:16:00:00.335	60 1.1700	145 34.6700	1020	
28	99	JUN 12, 1985	163:15:15:00.082	37 14.8713	116 29.3433		NTS EVENT



COMP = COMPENSATION
 FSK = FREQUENCY SHIFT KEYING
 TCG = TIME CODE GENERATOR
 VCO = VOLTAGE-CONTROLLED OSCILLATOR

Figure 22: Schematic diagram fo seismic recorder.

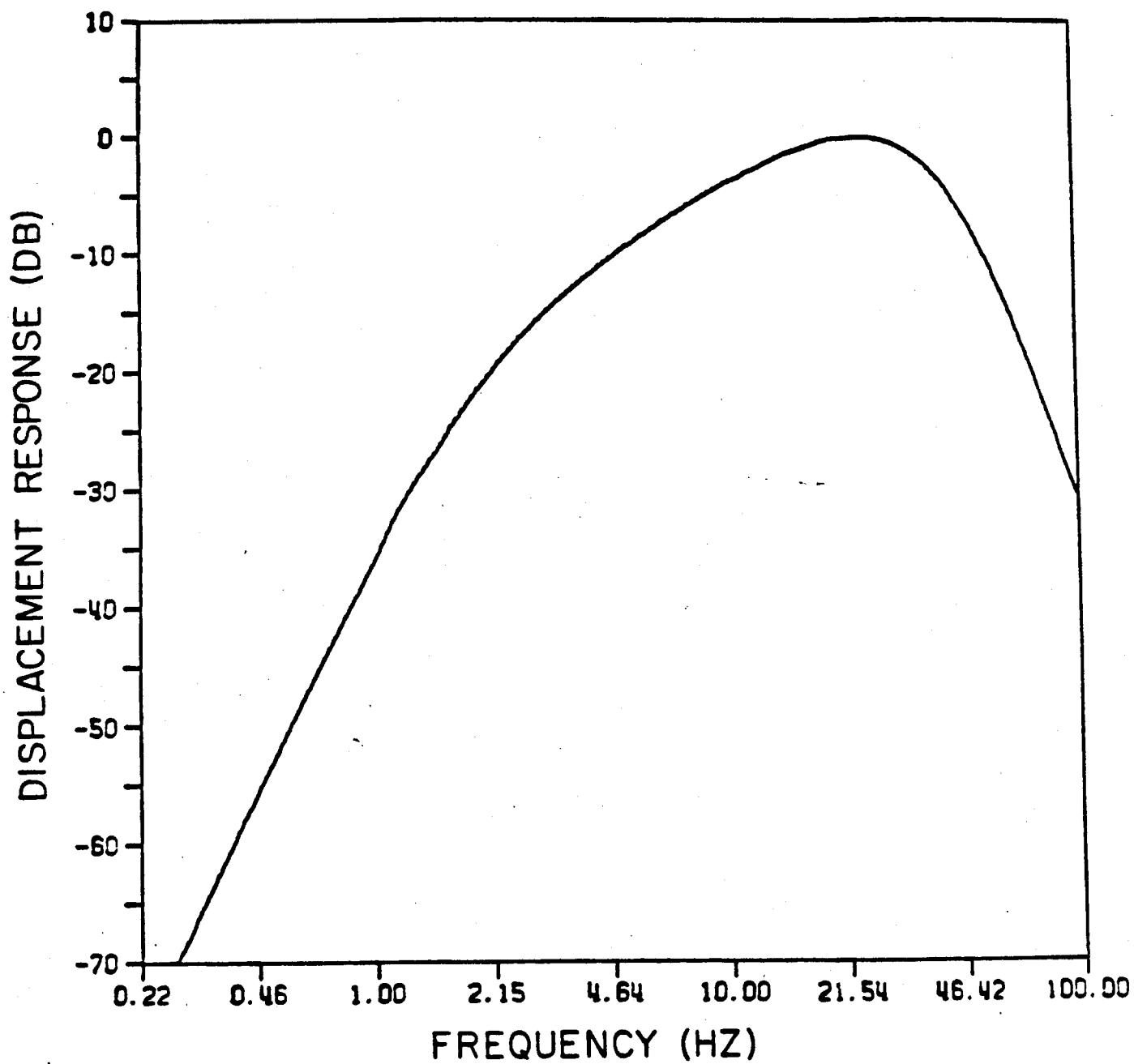

Figure 23: System response curve for cassette recording unit with 2-Hz seismometer.

Table 2: Seismic recorder locations. Includes location number, latitude, longitude, and elevation.

Lake Louise Deployment

Location number	Latitude (deg,min)	Longitude (deg,min)	Elev (m)	Location number	Latitude (deg,min)	Longitude (deg,min)	Elev (m)	Location number	Latitude (deg,min)	Longitude (deg,min)	Elev (m)
101	62 5.855	146 7.922	685	151	62 5.662	146 16.478	746	201	62 3.037	146 29.957	670
102	62 5.824	146 7.631	685	152	62 5.640	146 16.734	746	202	62 2.982	146 30.203	665
103	62 5.788	146 7.369	685	153	62 5.593	146 16.999	746	203	62 2.892	146 30.402	665
104	62 5.793	146 7.048	670	154	62 5.547	146 17.271	746	204	62 2.839	146 30.666	659
105	62 5.850	146 6.798	670	155	62 5.507	146 17.499	746	205	62 2.837	146 30.899	661
106	62 5.883	146 6.527	670	156	62 5.497	146 17.792	746	206	62 2.855	146 31.117	662
107	62 5.922	146 6.271	670	157	62 5.473	146 18.034	746	207	62 2.874	146 31.379	662
108	62 5.955	146 6.021	670	158	62 5.464	146 18.327	746	208	62 2.919	146 31.662	664
109	62 5.988	146 5.743	670	159	62 5.424	146 18.849	739	209	62 2.921	146 31.968	664
110	62 6.013	146 5.261	655	160	62 5.394	146 18.849	739	210	62 2.922	146 32.223	665
111	62 6.009	146 5.509	655	161	62 5.317	146 19.084	739	211	62 2.928	146 32.587	667
112	62 6.021	146 4.963	655	162	62 5.375	146 19.317	746	212	62 2.923	146 32.842	670
113	62 6.026	146 4.670	655	163	62 5.329	146 19.604	746	213	62 2.890	146 33.098	678
114	62 6.021	146 4.362	670	164	62 5.309	146 19.832	746	214	62 2.825	146 33.668	681
115	62 6.037	146 4.106	670	165	62 5.299	146 20.102	746	215	62 2.885	146 33.404	685
116	62 6.029	146 3.821	670	166	62 5.287	146 20.410	749	216	62 2.748	146 33.910	688
117	62 6.027	146 3.514	670	167	62 5.271	146 20.703	749	217	62 2.640	146 34.063	690
118	62 6.029	146 3.206	655	168	62 5.255	146 21.025	749	218	62 2.542	146 34.229	694
119	62 6.014	146 2.937	655	169	62 5.239	146 21.348	749	219	62 2.438	146 34.409	694
120	62 6.006	146 2.681	655	170	62 5.212	146 21.670	749	220	62 2.395	146 34.637	697
121	62 5.872	146 8.142	685	171	62 5.189	146 21.927	754				
122	62 5.890	146 8.453	693	172	62 5.139	146 22.134	754				
123	62 5.891	146 8.707	701	173	62 5.106	146 22.426	754				
124	62 5.879	146 9.027	701	174	62 5.047	146 22.661	754				
125	62 5.876	146 9.273	716	175	62 4.982	146 22.911	754				
126	62 5.890	146 9.593	716	176	62 4.935	146 23.198	768				
127	62 5.881	146 9.855	716	177	62 4.902	146 23.477	768				
128	62 5.872	146 10.150	731	178	62 4.837	146 23.712	768				
129	62 5.884	146 10.421	731	179	62 4.766	146 23.962	768				
130	62 5.871	146 10.690	739	180	62 4.671	146 24.169	768				
131	62 5.873	146 11.034	739	181	62 4.546	146 24.273	766				
132	62 5.874	146 11.282	739	182	62 4.447	146 24.407	762				
133	62 5.861	146 11.553	739	183	62 4.355	146 24.577	762				
134	62 5.856	146 11.896	746	184	62 4.302	146 24.798	762				
135	62 5.854	146 12.202	754	185	62 4.268	146 25.021	766				
136	62 5.845	146 12.473	754	186	62 4.238	146 25.276	766				
137	62 5.845	146 12.786	762	187	62 4.194	146 25.487	766				
138	62 5.841	146 13.057	762	188	62 4.163	146 25.757	763				
139	62 5.845	146 13.334	769	189	62 4.120	146 26.020	760				
140	62 5.840	146 13.567	769	190	62 4.059	146 26.282	755				
141	62 5.820	146 13.779	731	191	62 3.988	146 26.589	748				
142	62 5.811	146 14.130	731	192	62 3.920	146 26.946	745				
143	62 5.795	146 14.350	746	193	62 3.856	146 27.172	742				
144	62 5.776	146 14.627	746	194	62 3.792	146 27.449	739				
145	62 5.773	146 14.897	746	195	62 3.717	146 27.645	736				
146	62 5.754	146 15.171	746	196	62 3.645	146 27.856	734				
147	62 5.748	146 15.434	746	197	62 3.564	146 28.075	731				
148	62 5.725	146 15.689	746	198	62 3.507	146 28.279	719				
149	62 5.713	146 15.959	746	199	62 3.422	146 28.491	710				
150	62 5.685	146 16.191	746	200	62 3.344	146 28.732	701				

Tok Cutoff Deployment

Location number	Latitude (deg,min)	Longitude (deg,min)	Elev (m)	Location number	Latitude (deg,min)	Longitude (deg,min)	Elev (m)	Location number	Latitude (deg,min)	Longitude (deg,min)	Elev (m)
301	62 16.759	145 26.143	502	351	62 33.477	144 42.173	556	401	62 44.406	143 48.884	685
302	62 16.636	145 25.345	502	352	62 33.574	144 40.791	563	402	62 44.875	143 48.302	670
303	62 16.205	145 23.974	446	353	62 33.905	144 40.031	566	403	62 46.860	143 46.802	723
304	62 16.345	145 22.243	457	354	62 34.330	144 39.546	571	404	62 46.104	143 47.333	693
305	62 16.865	145 21.718	487	355	62 34.832	144 39.221	571	405	62 47.359	143 46.264	701
306	62 17.316	145 20.855	496	356	62 35.433	144 38.765	586	406	62 47.914	143 45.447	716
307	62 17.494	145 20.354	493	357	62 35.930	144 38.646	586	407	62 48.276	143 44.873	685
308	62 17.821	145 19.888	487	358	62 36.265	144 37.762	586	408	62 48.647	143 43.810	678
309	62 18.130	145 18.545	451	359	62 36.524	144 36.524	586	409	62 49.049	143 42.852	662
310	62 18.233	145 16.906	441	360	62 36.798	144 35.698	586	410	62 49.476	143 42.104	701
311	62 18.311	145 15.947	443	361	62 37.147	144 35.176	591	411	62 50.339	143 42.140	719
312	62 18.507	145 14.817	445	362	62 37.672	144 34.310	591	412	62 51.223	143 41.853	693
313	62 18.643	145 13.634	446	363	62 38.041	144 33.354	598	413	62 55.620	143 37.733	701
314	62 19.131	145 12.573	472	364	62 38.287	144 32.506	600	414	62 55.895	143 31.125	694
315	62 5.678	146 15.625	731	365	62 38.654	144 31.483	598	415	62 56.510	143 23.801	667
316	62 20.445	145 11.548	548	366	62 38.944	144 30.466	598	416	63 1.319	143 22.501	624
317	62 20.775	145 11.027	548	367	62 39.222	144 29.512	598	417	63 4.965	143 19.880	615
318	62 21.119	145 10.351	548	368	63 18.540	143 0.230	603	418	63 8.320	143 15.866	609
319	62 21.844	145 9.712	548	369	62 39.724	144 27.356	605	419	63 10.072	143 9.576	571
320	62 22.056	145 8.944	551	370	62 39.806	144 26.237	605	420	63 13.596	143 3.094	545
321	62 22.576	145 8.509	551	371	62 40.131	144 24.759	617	421	61 50.924	147 20.820	899
322	62 23.206	145 7.720	556	372	62 40.643	144 24.108	655				
323	62 23.761	145 6.953	557	373	62 41.103	144 23.727	676				
324	62 24.326	145 6.186	554	374	62 41.655	144 23.285	685				
325	62 24.824	145 5.038	551	375	62 42.184	144 22.680	701				
326	62 24.535	145 4.424	551	376	62 42.413	144 21.679	716				
327	62 24.602	145 2.451	518	377	62 42.558	144 20.387	746				
328	62 24.667	145 1.469	518	378	62 42.859	144 19.476	762				
329	62 24.868	145 0.536	521	379	62 42.878	144 17.951	762				
330	62 25.071	144 59.366	524	380	62 42.961	144 16.718	765				
331	62 25.625	144 58.447	533	381	62 43.019	144 15.425	762				
332	62 25.975	144 57.435	542	382	62 43.077	144 14.090	742				
333	62 25.935	144 56.185	574	383	62 42.877	144 12.442	762				
334	62 25.945	144 55.538	571	384	62 42.847	144 10.810	760				
335	62 26.553	144 54.662	569	385	62 42.917	144 9.777	777				
336	62 27.052	144 53.851	573	386	62 42.978	144 8.387	783				
337	62 27.433	144 52.820	566	387	62 43.028	144 6.980	798				
338	62 27.685	144 52.106	554	388	62 43.090	144 5.589	835				
339	62 27.966	144 50.814	536	389	62 43.112	144 4.162	777				
340	62 28.252	144 50.306	533	390	62 43.104	144 2.779	760				
341	62 29.073	144 49.491	662	391	62 43.077	144 1.321	754				
342	62 29.861	144 49.122	670	392	62 42.762	143 59.434	716				
343	62 30.306	144 48.700	533	393	62 43.173	143 58.116	701				
344	62 30.891	144 48.223	541	394	62 43.470	143 56.611	716				
345	62 31.510	144 47.770	548	395	62 43.581	143 55.434	731				
346	62 32.087	144 47.284	541	396	62 43.581	143 54.485	697				
347	62 32.586	144 46.356	556	397	62 43.512	143 53.307	697				
348	62 33.055	144 45.340	556	398	62 43.525	143 52.239	716				
349	62 33.187	144 44.480	556	399	62 43.791	143 50.980	694				
350	62 33.291	144 43.300	556	400	62 44.111	143 49.803	662				

Montague Deployment

Location number	Latitude (deg,min)	Longitude (deg,min)	Elev (m)	Location number	Latitude (deg,min)	Longitude (deg,min)	Elev (m)	Location number	Latitude (deg,min)	Longitude (deg,min)	Elev (m)
501	60 40.126	145 47.556	335	553	60 24.755	146 35.670	304	604	60 3.921	147 28.137	60
502	60 39.290	145 47.703	30	554	60 24.867	146 36.395	91	605	60 3.863	147 29.029	152
503	60 38.628	145 47.926	42	555	60 24.606	146 38.117	365	606	60 3.648	147 30.340	76
504	60 38.023	145 48.335	60	556	60 24.261	146 38.864	167	607	60 3.320	147 30.982	91
505	60 37.672	145 49.645	60	557	60 23.987	146 39.605	60	608	60 2.635	147 31.628	198
506	60 37.492	145 50.389	60	558	60 23.459	146 40.720	167	609	60 2.529	147 32.708	320
507	60 37.315	145 51.845	30	559	60 23.022	146 41.193	121	610	60 2.099	147 33.479	243
508	60 37.028	145 52.623	15	560	60 22.310	146 42.411	228	612	60 1.275	147 34.829	15
509	60 36.846	145 53.644	60	561	60 22.123	146 42.411	91	613	60 0.810	147 35.385	182
510	60 35.071	145 52.667	60	562	60 21.102	146 43.237	152	614	60 0.621	147 36.562	60
511	60 35.170	145 53.832	213	563	60 20.773	146 42.901	274	615	60 0.367	147 37.480	30
512	60 34.773	145 55.096	91	564	60 17.913	146 55.345	54	616	59 59.042	147 37.673	137
513	60 34.770	145 55.876	91	565	60 17.836	146 56.088	91	617	59 58.798	147 38.098	30
514	60 34.575	145 56.941	30	566	60 17.359	146 57.271	152	618	59 58.360	147 38.067	22
515	60 34.336	145 57.973	15	567	60 17.085	146 58.126	213	619	59 57.745	147 39.116	76
516	60 33.983	145 59.408	45	568	60 17.089	146 58.559	152	620	59 57.298	147 39.709	45
517	60 33.477	145 59.562	30	569	60 16.848	147 0.803	137	621	59 56.929	147 40.540	15
518	60 33.103	146 0.597	30	570	60 16.581	147 1.703	99	622	59 56.697	147 41.497	30
520	60 32.264	146 1.856	91	571	60 16.398	147 2.138	152	623	59 56.515	147 42.197	121
521	60 32.206	146 3.084	106	572	60 16.099	147 3.586	60				
522	60 31.983	146 4.361	137	573	60 15.804	147 4.287	68				
523	60 31.801	146 5.489	30	574	60 15.551	147 5.166	73				
524	60 31.722	146 6.617	91	575	60 15.263	147 6.156	60				
525	60 31.492	146 7.057	36	576	60 15.269	147 6.905	60				
526	60 30.944	146 7.783	30	577	60 15.000	147 8.271	152				
527	60 30.447	146 8.511	106	578	60 14.758	147 9.102	176				
528	60 30.271	146 9.802	167	579	60 14.208	147 10.398	121				
529	60 29.855	146 10.563	152	580	60 13.929	147 10.924	167				
530	60 29.612	146 11.530	91	581	60 13.559	147 11.766	213				
531	60 29.181	146 12.201	182	582	60 13.313	147 12.854	91				
532	60 28.858	146 13.152	213	583	60 12.627	147 13.343	137				
533	60 28.530	146 14.021	121	584	60 12.431	147 14.358	60				
534	60 28.372	146 14.936	121	585	60 12.431	147 16.054	152				
535	60 28.346	146 16.547	121	587	60 11.515	147 16.889	121				
536	60 28.218	146 17.724	182	588	60 10.889	147 17.370	60				
537	60 28.166	146 19.024	91	589	60 10.469	147 18.270	45				
538	60 28.024	146 19.614	30	590	60 10.066	147 19.020	106				
539	60 27.928	146 21.342	15	591	60 9.822	147 19.679	60				
540	60 27.931	146 22.387	60	592	60 9.426	147 20.641	76				
541	60 27.678	146 23.704	121	593	60 9.407	147 21.434	30				
542	60 27.488	146 24.625	158	594	60 8.785	147 21.854	45				
543	60 27.130	146 25.399	182	595	60 7.617	147 21.739	45				
544	60 26.989	146 26.441	152	596	60 6.669	147 22.195	152				
545	60 26.514	146 27.297	97	597	60 6.669	147 22.813	182				
546	60 26.614	146 28.685	91	598	60 6.434	147 23.965	60				
547	60 26.461	146 29.920	207	599	60 6.176	147 24.683	137				
548	60 26.171	146 31.010	243	600	60 5.808	147 25.496	106				
549	60 26.110	146 32.025	304	601	60 4.898	147 25.250	243				
550	60 25.594	146 32.387	213	602	60 4.486	147 26.683	106				
552	60 25.176	146 34.813	190	603	60 4.108	147 26.924	152				

Cordova Peak Deployment

Location number	Latitude (deg,min)	Longitude (deg,min)	Elev (m)	Location number	Latitude (deg,min)	Longitude (deg,min)	Elev (m)	Location number	Latitude (deg,min)	Longitude (deg,min)	Elev (m)
701	60 26.116	145 18.041	7	752	60 54.224	145 15.929	1203	802	61 23.285	145 13.648	457
702	60 26.651	145 19.089	7	753	60 54.224	145 17.909	1082	803	61 23.793	145 12.412	457
703	60 27.160	145 19.678	7	754	60 54.981	145 16.181	1036	804	61 24.223	145 10.993	487
704	60 27.708	145 20.648	7	755	60 55.099	145 18.276	968	805	61 24.602	145 10.330	487
705	60 28.172	145 20.735	12	756	60 55.507	145 18.875		806	61 25.263	145 9.060	518
706	60 28.697	145 20.872	12	757	60 56.033	145 18.835	920	807	61 25.750	145 7.722	548
707	60 29.226	145 20.988	18	758	60 56.870	145 18.796	822	808	61 26.222	145 6.958	479
708	60 29.752	145 21.036	24	759	60 57.379	145 18.798	809	809	61 26.698	145 6.573	579
709	60 30.289	145 21.112	51	760	60 57.382	145 17.082	783	810	61 27.252	145 6.758	579
710	60 30.394	145 21.374	57	761	60 58.381	145 17.392	716	811	61 27.803	145 7.492	579
711	60 31.513	145 21.734	82	762	60 58.316	145 18.822	716	812	61 29.152	145 9.415	560
712	60 32.094	145 22.047	91	763	60 59.089	145 17.294	548	813	61 29.582	145 10.833	554
713	60 32.775	145 21.638	694	764	60 59.587	145 16.799	502	814	61 30.072	145 11.802	554
714	60 33.124	145 21.979	457	765	61 0.053	145 16.271	445	815	61 30.502	145 12.622	560
715	60 33.633	145 22.584	731	766	61 0.621	145 15.341	390	816	61 30.928	145 13.207	563
716	60 34.191	145 21.710	679	767	61 1.071	145 15.188	213	817	61 31.747	145 14.050	557
717	60 34.683	145 21.799	228	768	61 1.783	145 15.590	152	832	60 48.398	145 16.135	304
718	60 35.142	145 22.065	396	769	61 2.330	145 15.448	152	833	60 48.937	145 15.749	426
719	60 35.747	145 22.655	655	770	61 2.660	145 16.637	152	834	61 56.997	145 16.748	
720	60 36.290	145 22.649	441	771	61 3.347	145 17.853	251	835	62 16.762	145 16.150	
721	60 36.776	145 21.776	411	772	61 4.035	145 18.037	640				
722	60 37.321	145 24.134	143	773	61 4.565	145 18.408	960				
723	60 37.879	145 22.919	265	774	61 5.143	145 18.153	1264				
724	60 38.433	145 22.348	198	775	61 5.600	145 18.365	1219				
725	60 39.077	145 22.027	585	776	61 6.047	145 18.487					
726	60 39.727	145 22.049	518	777	61 6.935	145 19.167	1874				
727	60 40.112	145 21.981	707	778	61 8.823	145 18.580	426				
728	60 40.767	145 22.025	883	779	61 10.167	145 17.358	1219				
729	60 41.245	145 20.813	1234	780	61 10.717	145 17.280	423				
730	60 41.864	145 19.225	807	781	61 11.430	145 17.653	425				
731	60 42.345	145 17.771	441	782	61 12.190	145 18.875	438				
732	60 42.618	145 17.293	914	783	61 13.008	145 20.317	437				
733	60 43.277	145 16.521	1097	784	61 13.585	145 20.068	435				
734	60 43.787	145 15.631	990	785	61 14.182	145 18.967	320				
735	60 44.282	145 14.627	1158	786	61 15.013	145 17.947	327				
736	60 44.782	145 16.344	990	787	61 15.300	145 17.110	335				
737	60 45.339	145 17.831	1143	788	61 15.825	145 16.890	335				
738	60 45.488	145 16.913	944	789	61 16.347	145 16.762	335				
739	60 46.540	145 16.913	914	790	61 16.805	145 16.314	393				
740	60 47.312	145 16.515	838	791	61 17.360	145 16.178	393				
741	60 47.670	145 16.235	1002	792	61 17.855	145 16.298	405				
742	60 49.387	145 15.621	1264	793	61 18.503	145 16.595	411				
743	60 49.706	145 15.112	1447	794	61 19.080	145 17.735	403				
744	60 49.953	145 14.571	1447	795	61 19.653	145 18.665	381				
745	60 50.750	145 14.275	1316	796	61 20.198	145 18.543	344				
746	60 51.514	145 13.631	1152	797	61 20.698	145 18.437	350				
747	60 51.942	145 13.232	975	798	61 21.208	145 17.733	363				
748	60 52.497	145 14.324	1112	799	61 21.678	145 16.817	402				
749	60 52.977	145 13.496	929	800	61 22.310	145 16.062	411				
750	60 53.301	145 14.760	1463	801	61 22.878	145 14.787	441				
751	60 53.978	145 15.941	1234								

NTS Event Deployment

Location number	Latitude (deg,min)	Longitude (deg,min)	Elev (m)
104	62 8.960	145 28.411	
106	62 7.756	145 28.572	
108	62 6.855	145 28.508	
110	62 5.931	145 27.700	
112	62 4.936	145 26.006	
572	62 45.518	145 27.523	822
574	62 44.181	145 26.030	807
576	62 43.059	145 25.914	807
578	62 41.845	145 26.718	722
580	62 40.607	145 27.811	774
582	62 39.386	145 28.947	740
584	62 38.209	145 28.266	731
585	62 37.718	145 27.200	679
586	62 37.029	145 26.505	676
588	62 35.822	145 27.580	676
591	62 34.618	145 29.290	640
602	62 32.855	145 30.493	600
604	62 31.610	145 30.740	579
606	62 30.474	145 30.101	594
608	62 29.431	145 27.957	582
610	62 28.107	145 25.447	579
612	62 26.968	145 24.654	563
614	62 25.757	145 24.508	569
616	62 24.557	145 22.824	542
618	62 23.403	145 21.950	
620	62 22.207	145 21.887	539
622	62 20.965	145 21.903	533
624	62 19.799	145 21.334	509
626	62 18.632	145 20.493	502
628	62 17.442	145 21.067	496
630	62 16.129	145 23.573	445
632	62 14.953	145 25.626	487
634	62 13.742	145 26.141	484
636	62 12.548	145 26.435	484
638	62 11.323	145 26.912	484

Appendix A

Field Data Tables. These include information related to the seismic recorders. Each set of 20 recorders is given a team number under which data is stored and referenced. Each table contains shot number, shotpoint numbers, team number, and shot time given in julian day, hour, minute, and second. Column headings for the table are explained below:

Loc	- location number of the seismic recorder (see Table 2).
Dist (km)	- distance in kilometers from the shotpoint to the recorder.
Azim	- azimuth from the shotpoint to the recorder. (in degrees clockwise from north).
Unit	- I.D. number of the recording unit.
Chron	- chronometer correction for the recorder at shot time (interpolated from the total clock drift).
C1, C2, C3	- amplifier attenuation setting (db) for each of three data-recording channels. The gain of each channel is determined by subtracting the given attenuation from a total gain of 102 db.

Tape Grade Scale

Scale is a listing of all tape grade numbers used on the Field Data Tables. Each number corresponds to the performance of each recording unit.

0	Good, tape ran
1	Tape did not run
3	Skipped record time
4	No seismic signal
6	Bad time code
7	Noise - continuous calibration or periodic offsets
8	Noise - sinusoidal
9	Noise - Spike
12	Noise - Random
16	Incomplete record - recorder stopped
17	Noisy time code
20	Not deployed
21	Bad geophone
29	Wrong programmed instrument turn on time

FIELD DATA TABLE

Shot number 1 Shot point 14 Team 1
Shot time: 159: 0:30: 0.012

Loc	Dist(km)	Azim	Unit	Chron	Chan	C1	C2	C3	Tape
									grade
1	9.826	84.3	1	5	3	30	12	48	0
2	10.072	84.8	2	3	3	30	12	48	0
3	10.294	85.2	3	3	3	30	12	48	0
4	10.573	85.3	4	-7	3	30	12	48	0
5	10.799	84.9	5	4	1	30	12	48	0
6	11.039	84.7	6	1	3	30	12	48	0
7	11.269	84.4	7	3	3	30	12	48	0
8	11.490	84.2	8	4	3	30	12	48	0
9	11.737	84.0	9	5	1	30	12	48	0
10	11.945	83.9	10	2	1	30	12	48	0
11	12.159	84.0	11	-9	1	30	12	48	0
12	12.419	84.1	12	2	3	30	12	48	0
13	12.674	84.1	13	2	1	30	12	48	0
14	12.939	84.3	14	-5	1	30	12	48	0
15	13.164	84.3	15	2	1	30	6	48	0
16	13.410	84.4	16	0	1	30	12	48	0
17	13.676	84.6	17	5	1	30	12	48	0
18	13.943	84.6	18	-4	1	30	12	48	0
19	14.174	84.8	19	9	3	30	12	48	0
20	14.395	85.0	20	0	3	30	12	48	0/ 9

FIELD DATA TABLE

Shot number 1 Shot point 14 Team 3
Shot time: 159: 0:30: 0.012

Loc	Dist(km)	Azim	Unit	Chron	Chan	C1	C2	C3	Tape
									grade
1	4.766	79.0	41	-6	3	30	12	48	0
2	4.462	78.4	42	3	3	30	12	48	0
3	4.269	78.3	43	-3	3	30	12	48	0
4	4.025	78.1	44	7	3	30	12	48	0
5	3.794	77.4	45	0	3	30	12	48	0
6	3.554	77.2	46	3	3	30	12	48	0
7	3.329	76.5	47	1	3	30	12	48	0
8	3.103	76.3	48	4	3	30	12	48	0
9	2.870	75.6	49	4	3	30	12	48	0
10	2.661	75.6	50	-6	3	30	12	48	0
11	2.409	75.1	51	6	3	30	12	48	0
12	2.182	74.7	52	-3	3	30	12	48	0
13	1.937	75.3	53	2	3	30	12	48	0
14	1.687	76.1	54	0	3	30	12	48	0
15	1.476	77.0	55	9	3	30	12	48	0
16	1.223	75.2	56	6	3	30	12	48	0
17	1.009	74.6	57	4	3	30	12	68	0
18	0.760	70.7	58	4	3	30	12	68	0
19	0.530	70.5	59	0	3	30	12	88	0
20	0.290	65.2	60	-2	3	30	12	88	0

FIELD DATA TABLE

Shot number 1 Shot point 14 Team 2
Shot time: 159: 0:30: 0.012

Loc	Dist(km)	Azim	Unit	Chron	Chan	C1	C2	C3	Tape
									grade
1	9.638	84.0	21	-3	3	30	12	48	0
2	9.372	83.6	22	2	3	30	12	48	0
3	9.153	83.4	23	5	3	30	12	48	0
4	8.874	83.4	24	0	2	30	12	48	0
5	8.660	83.3	25	0	3	30	12	48	0
6	8.388	82.9	26	1	3	30	12	48	0
7	8.159	82.8	27	1	3	30	12	48	0
8	7.901	82.7	28	-13	3	30	12	48	1
9	7.670	82.3	29	2	3	30	12	48	0
10	7.435	82.2	30	2	3	30	12	48	0
11	7.139	81.9	31	1	3	30	12	48	0
12	6.926	81.6	32	7	3	30	12	48	0
13	6.689	81.5	33	7	3	30	12	48	0
14	6.393	81.2	34	3	3	30	12	48	0
15	6.128	80.8	35	-6	3	30	12	48	1
16	5.894	80.6	36	2	3	30	12	48	0
17	5.627	80.0	37	0	3	30	12	48	0
18	5.391	79.8	38	0	3	30	12	48	0
19	5.155	79.3	39	0	3	30	12	48	0
20	4.953	79.0	40	-2	3	30	12	48	0

FIELD DATA TABLE

Shot number 1 Shot point 14 Team 4
Shot time: 159: 0:30: 0.012

Loc	Dist(km)	Azim	Unit	Chron	Chan	C1	C2	C3	Tape
									grade
1	0.062	110.8	61	2	3	30	12	88	0
2	0.169	300.6	62	0	3	30	12	88	0
3	0.395	269.9	63	1	3	30	12	88	0
4	0.594	266.4	64	5	3	30	12	68	0
5	0.829	266.2	65	0	3	30	12	68	0
6	1.039	265.9	66	2	3	30	12	68	0
7	1.356	265.4	67	-2	3	30	12	48	0
8	1.639	265.2	68	0	3	30	12	48	0
9	1.921	265.0	69	0	3	30	12	48	0
10	2.205	264.4	70	9	3	30	12	48	0
11	2.431	263.9	71	0	3	30	12	48	0
12	2.640	262.3	72	4	3	30	12	48	0
13	2.882	261.7	73	-7	3	30	12	48	0
14	3.101	260.3	74	0	2	30	12	48	0
15	3.337	258.9	75	3	3	30	12	48	0
16	3.600	258.3	76	0	3	30	12	48	0
17	3.850	258.1	77	2	3	30	12	48	0
18	4.076	257.1	78	0	3	30	12	48	0
19	4.319	256.0	79	--	3	30	12	48	1
20	4.538	254.4	80	2	3	30	12	48	0

FIELD DATA TABLE

Shot number 1 Shot point 14 Team 5
Shot time: 159: 0:30: 0.012

Loc	Dist(km)	Azim	Unit	Chron	Chan	C1	C2	C3	Tape grade
1	4.693	251.9	81	-5	3	30	12	48	0
2	4.862	250.3	82	0	3	30	12	48	0
3	5.060	249.1	83	5	3	30	12	48	0
4	5.275	248.8	84	-2	3	30	12	48	0
5	5.480	248.9	85	3	3	30	12	48	0
6	5.708	249.2	86	0	3	30	12	48	0
7	5.909	249.1	87	1	3	30	12	48	0
8	6.148	249.4	88	4	3	30	12	48	0
9	6.391	249.4	89	0	3	30	12	48	0
10	6.645	249.2	90	2	3	30	12	48	0
11	6.941	249.0	91	3	3	30	12	48	0
12	7.278	248.9	92	0	3	30	12	48	0
13	7.504	248.6	93	2	3	30	12	48	0
14	7.773	248.4	94	5	3	30	12	48	0
15	7.982	248.0	95	0	1	30	12	48	0
16	8.203	247.6	96	-3	1	30	12	48	0
17	8.437	247.1	97	1	3	30	12	48	0
18	8.643	246.9	98	-6	3	30	12	48	0
19	8.875	246.5	99	5	3	30	12	48	0
20	9.125	246.2	100	3	1	30	12	48	0

FIELD DATA TABLE

Shot number 2 Shot point 7 Team 1
Shot time: 159: 0:32: 0.014

Loc	Dist(km)	Azim	Unit	Chron	Chan	C1	C2	C3	Tape grade
1	38.094	258.5	1	5	1	30	12	48	0
2	37.858	258.3	2	4	1	30	12	48	0
3	37.649	258.2	3	3	1	30	12	48	0
4	37.373	258.1	4	-7	1	30	12	48	0
5	37.138	258.2	5	4	2	30	12	48	0
6	36.896	258.2	6	1	3	30	12	48	0
7	36.661	258.2	7	3	3	30	12	48	0
8	36.437	258.3	8	4	1	30	12	48	0
9	36.187	258.3	9	5	1	30	12	48	0
10	35.977	258.3	10	2	1	30	12	48	0
11	35.768	258.2	11	-9	1	30	12	48	0
12	35.510	258.2	12	2	1	30	12	48	0
13	35.259	258.1	13	2	1	30	12	48	0
14	34.999	258.0	14	-5	1	30	12	48	0
15	34.775	258.0	15	2	1	30	6	48	0
16	34.536	257.9	16	0	1	30	12	48	0
17	34.275	257.8	17	5	1	30	12	48	0
18	34.013	257.7	18	-4	1	30	12	48	0
19	33.791	257.5	19	9	1	30	12	48	0
20	33.576	257.4	20	0	1	30	12	48	0

FIELD DATA TABLE

Shot number 1 Shot point 14 Team 6
Shot time: 159: 0:30: 0.012

Loc	Dist(km)	Azim	Unit	Chron	Chan	C1	C2	C3	Tape grade
1	10.334	245.7	101	8	3	30	12	48	0
2	10.571	245.6	102	6	1	30	12	48	0
3	10.799	245.2	103	4	1	30	12	48	1
4	11.048	245.3	104	2	1	30	12	48	0
5	11.235	245.7	105	11	1	30	12	48	0
6	11.395	246.2	106	2	1	30	12	48	0
7	11.590	246.8	107	11	1	30	12	48	12
8	11.785	247.7	108	3	3	30	12	48	1
9	12.030	248.2	109	5	3	30	12	48	0
10	12.236	248.6	110	9	3	30	12	48	0
11	12.528	249.1	111	17	3	30	12	48	0
12	12.739	249.5	112	6	1	30	12	48	0
13	12.970	249.6	113	0	1	30	12	48	0
14	13.478	249.8	114	2	3	30	12	48	0
15	13.224	249.9	115	6	1	30	12	48	0
16	13.726	249.6	116	8	1	30	12	48	0
17	13.923	249.0	117	5	1	30	12	48	0
18	14.122	248.5	118	7	1	30	12	48	0
19	14.341	248.0	119	4	1	30	12	48	0
20	14.571	248.0	120	4	1	30	12	48	0

FIELD DATA TABLE

Shot number 2 Shot point 7 Team 2
Shot time: 159: 0:32: 0.014

Loc	Dist(km)	Azim	Unit	Chron	Chan	C1	C2	C3	Tape grade
1	38.275	258.6	21	-3	3	30	12	48	0
2	38.533	258.7	22	2	1	30	12	48	0
3	38.749	258.8	23	5	1	30	12	48	0
4	39.027	258.9	24	0	1	30	12	48	1
5	39.238	258.9	25	0	1	30	12	48	0
6	39.505	259.0	26	1	1	30	12	48	0
7	39.733	259.1	27	1	1	30	12	48	0
8	39.988	259.1	28	-13	1	30	12	48	1
9	40.216	259.2	29	2	1	30	12	48	0
10	40.450	259.2	30	2	1	30	12	48	0
11	40.743	259.3	31	1	1	30	12	48	0
12	40.954	259.4	32	7	1	30	12	48	0
13	41.190	259.4	33	7	1	30	12	48	0
14	41.485	259.5	34	3	1	30	12	48	0
15	41.748	259.5	35	-6	1	30	12	48	1
16	41.982	259.6	36	2	1	30	12	48	0
17	42.248	259.6	37	0	1	30	12	48	0
18	42.483	259.7	38	0	1	30	12	48	0
19	42.719	259.7	39	0	3	30	12	48	0
20	42.921	259.8	40	-2	3	30	12	48	0

FIELD DATA TABLE

Shot number 2 Shot point 7 Team 3
Shot time: 159: 0:32: 0.014

Loc	Dist(km)	Azim	Unit	Chron	Chan	C1	C2	C3	Tape grade
1	43.108	259.8	41	-6	3	30	12	48	0
2	43.412	259.8	42	3	3	30	12	48	0
3	43.606	259.8	43	-3	1	30	12	48	0
4	43.850	259.8	44	7	1	30	12	48	0
5	44.082	259.9	45	0	3	30	12	48	0
6	44.323	259.9	46	3	3	30	12	48	0
7	44.550	259.9	47	1	3	30	12	48	0
8	44.776	259.9	48	4	3	30	12	48	0
9	45.011	259.9	49	4	4	30	12	48	1
10	45.219	259.9	50	-6	1	30	12	48	0
11	45.472	259.9	51	6	2	30	12	48	0
12	45.699	259.9	52	-3	1	30	12	48	0
13	45.941	259.9	53	2	1	30	12	48	0
14	46.190	259.8	54	0	1	30	12	48	0
15	46.399	259.8	55	10	1	30	12	48	0
16	46.654	259.8	56	6	2	30	12	48	0
17	46.869	259.8	57	4	1	30	12	68	0
18	47.122	259.8	58	4	1	30	12	68	0
19	47.350	259.8	59	0	1	30	12	88	0
20	47.593	259.8	60	-2	1	30	12	88	12

FIELD DATA TABLE

Shot number 2 Shot point 7 Team 5
Shot time: 159: 0:32: 0.014

Loc	Dist(km)	Azim	Unit	Chron	Chan	C1	C2	C3	Tape grade
1	52.532	259.0	81	-5	1	30	12	48	0
2	52.683	258.8	82	0	3	30	12	48	0
3	52.862	258.7	83	5	1	30	12	48	0
4	53.070	258.6	84	-2	1	30	12	48	0
5	53.275	258.6	85	3	1	30	12	48	0
6	53.504	258.6	86	0	3	30	12	48	0
7	53.700	258.5	87	1	1	30	12	48	0
8	53.942	258.5	88	4	2	30	12	48	0
9	54.182	258.5	89	0	2	30	12	48	0
10	54.430	258.4	90	2	2	30	12	48	0
11	54.719	258.3	91	3	1	30	12	48	0
12	55.050	258.3	92	0	2	30	12	48	0
13	55.267	258.2	93	2	1	30	12	48	0
14	55.529	258.1	94	5	1	30	12	48	0
15	55.725	258.0	95	0	2	30	12	48	0
16	55.933	257.9	96	-3	2	30	12	48	0
17	56.152	257.8	97	1	2	30	12	48	0
18	56.349	257.8	98	-6	1	30	12	48	0
19	56.565	257.6	99	5	2	30	12	48	0
20	56.801	257.5	100	3	2	30	12	48	0

FIELD DATA TABLE

Shot number 2 Shot point 7 Team 4
Shot time: 159: 0:32: 0.014

Loc	Dist(km)	Azim	Unit	Chron	Chan	C1	C2	C3	Tape grade
1	47.821	259.7	61	2	1	30	12	88	0
2	48.001	259.8	62	0	2	30	12	88	0
3	48.262	259.8	63	1	2	30	12	88	0
4	48.464	259.8	64	5	1	30	12	68	0
5	48.697	259.8	65	0	1	30	12	68	0
6	48.966	259.8	66	3	1	30	12	68	0
7	49.222	259.8	67	-2	1	30	12	48	0
8	49.504	259.9	68	0	1	30	12	48	0
9	49.786	259.9	69	0	2	30	12	48	0
10	50.070	259.9	70	9	2	30	12	48	0
11	50.298	259.9	71	0	2	30	12	48	0
12	50.510	259.8	72	4	2	30	12	48	0
13	50.753	259.8	73	-7	2	30	12	48	0
14	50.975	259.7	74	0	2	30	12	48	0
15	51.211	259.6	75	3	2	30	12	48	0
16	51.474	259.6	76	0	1	30	12	48	0
17	51.723	259.6	77	2	2	30	12	48	0
18	51.947	259.5	78	0	2	30	12	48	0
19	52.186	259.4	79	--	2	30	12	48	1
20	52.397	259.2	80	2	1	30	12	48	0

FIELD DATA TABLE

Shot number 2 Shot point 7 Team 6
Shot time: 159: 0:32: 0.014

Loc	Dist(km)	Azim	Unit	Chron	Chan	C1	C2	C3	Tape grade
1	57.971	257.2	101	8	1	30	12	48	0
2	58.203	257.2	102	6	6	30	12	48	1
3	58.411	257.0	103	4	4	30	12	48	1
4	58.657	257.0	104	2	3	30	12	48	0
5	58.856	257.0	105	11	3	30	12	48	0
6	59.033	257.1	106	2	2	30	12	48	0
7	59.247	257.2	107	11	11	30	12	48	12
8	59.468	257.3	108	3	3	30	12	48	1
9	59.727	257.4	109	5	2	30	12	48	0
10	59.943	257.4	110	9	1	30	12	48	0
11	60.251	257.5	111	17	1	30	12	48	0
12	60.469	257.5	112	6	2	30	12	48	0
13	60.700	257.5	113	0	2	30	12	48	0
14	61.212	257.5	114	2	1	30	12	48	0
15	60.963	257.6	115	6	2	30	12	48	0
16	61.450	257.4	116	8	1	30	12	48	0
17	61.627	257.3	117	5	3	30	12	48	0
18	61.808	257.2	118	7	1	30	12	48	0
19	62.006	257.0	119	4	2	30	12	48	0
20	62.235	257.0	120	4	2	30	12	48	0

FIELD DATA TABLE

Shot number 3 Shot point 15 Team 1
Shot time: 161: 7: 0: 0.009

Loc	Dist(km)	Azim	Unit	Chron	Chan	C1	C2	C3	Tape	grade
1	301	37.509	235.6	1	10	1	30	12 88	0	0
2	302	37.075	234.7	2	8	1	30	12 88	0	0
3	303	36.600	232.6	3	5	1	30	12 68	0	0
4	304	35.263	231.5	4	-18	1	30	12 48	0	0
5	305	34.306	232.2	5	8	1	30	12 48	0	0
6	306	33.203	232.6	6	4	1	30	12 48	0	0
7	307	32.658	232.6	7	-2	1	30	12 48	1	1
8	308	31.969	233.0	8	9	30	12 48	12	12	0
9	309	30.697	232.6	9	12	1	30	12 48	0	0
10	310	29.467	231.2	10	2	1	30	12 48	0	0
11	311	28.668	230.3	11	-31	1	30	12 48	0	0
12	312	27.753	229.7	12	3	1	30	12 48	0	0
13	313	26.829	228.7	13	4	1	30	12 48	0	0
14	314	25.528	228.8	14	-12	1	30	12 48	0	0
15	315	84.556	240.5	15	0	2	30	12 88	0	0
16	316	23.285	231.9	16	-3	3	30	12 48	0	0
17	317	22.553	232.4	17	12	11	30	12 48	29	29
18	318	21.701	232.8	18	-11	11	30	12 48	12	12
19	319	20.460	234.9	19	16	3	30	12 48	0	0
20	320	19.691	234.7	20	-3	1	30	12 48	0	0

Shot number 3 Shot point 15 Team 3
Shot time: 161: 7: 0: 0.009

Loc	Dist(km)	Azim	Unit	Chron	Chan	C1	C2	C3	Tape	grade
1	341	1.799	22.0	41	-7	3	30	12 68	0	0
2	342	3.284	17.6	42	4	3	30	12 48	0	0
3	343	4.184	18.9	43	1	3	30	12 48	0	0
4	344	5.344	19.3	44	8	3	30	12 48	0	0
5	345	6.557	19.2	45	1	3	30	12 48	0	0
6	346	7.708	19.5	46	2	3	30	12 48	0	0
7	347	8.859	22.3	47	-3	3	30	12 48	0	0
8	348	10.007	25.1	48	0	3	30	12 48	0	0
9	349	10.557	28.1	49	1	3	30	12 48	0	0
10	350	11.233	32.2	50	-12	3	30	12 48	0	0
11	351	12.058	35.2	51	9	3	30	12 48	0	0
12	352	12.919	39.1	52	-4	3	30	12 48	0	0
13	353	13.808	39.6	53	6	3	30	12 48	0	0
14	354	14.682	38.9	54	-3	3	30	12 48	0	0
15	355	15.586	37.5	55	6	1	30	12 68	0	0
16	356	16.713	36.2	56	11	1	30	12 68	0	0
17	357	17.524	34.7	57	7	1	30	12 68	0	0
18	358	18.469	35.5	58	7	1	30	12 88	0	0
19	359	19.073	38.2	59	0	1	30	12 88	0	0
20	360	20.321	38.0	60	-3	1	30	12 88	0	0

FIELD DATA TABLE

Shot number 3 Shot point 15 Team 2
Shot time: 161: 7: 0: 0.009

Loc	Dist(km)	Azim	Unit	Chron	Chan	C1	C2	C3	Tape	grade
1	321	18.834	236.5	21	-2	3	30	12 48	0	0
2	322	17.629	238.4	22	6	3	30	12 48	0	0
3	323	16.534	240.3	23	11	30	12 48	12	12	0
4	324	15.406	242.7	24	0	30	12 48	12	12	0
5	325	14.583	240.6	25	5	1	30	12 68	0	0
6	326	13.929	241.0	26	2	1	30	12 68	0	0
7	327	12.405	237.7	27	29	1	30	12 88	0	0
8	328	11.630	235.9	28	-46	30	12 88	3	3	0
9	329	10.757	235.2	29	5	30	12 68	12	12	0
10	330	9.719	233.6	30	3	3	30	12 68	0	0
11	331	8.478	236.0	31	4	3	30	12 48	0	0
12	332	7.392	236.4	32	18	30	12 48	3	3	0
13	333	6.570	230.7	33	14	3	30	12 48	0	0
14	334	6.137	227.5	34	6	30	12 48	12	12	0
15	335	4.828	231.4	35	-15	30	12 48	12	12	0
16	336	3.715	235.8	36	2	3	30	12 48	0	0
17	337	2.586	237.8	37	1	3	30	12 68	0	0
18	338	1.819	239.9	38	2	3	30	12 68	0	0
19	339	0.604	230.0	39	1	3	30	12 88	0	0
20	340	0.145	350.0	40	4	3	30	12 88	0	0

FIELD DATA TABLE

Shot number 3 Shot point 15 Team 4
Shot time: 161: 7: 0: 0.009

Loc	Dist(km)	Azim	Unit	Chron	Chan	C1	C2	C3	Tape	grade
1	361	21.108	37.9	61	13	1	30	12 68	0	0
2	362	22.332	37.8	62	1	1	30	12 48	0	0
3	363	23.376	38.4	63	7	3	30	12 48	0	0
4	364	24.186	39.0	64	25	3	30	12 48	0	0
5	365	25.269	39.6	65	-5	3	30	12 48	0	0
6	366	26.242	40.3	66	14	1	30	12 48	0	0
7	367	27.165	40.9	67	0	1	30	12 48	0	0
8	368	131.703	44.9	68	-4	1	30	12 48	0	0
9	369	29.089	42.5	69	2	30	12 48	16	16	0
10	370	29.855	43.6	70	39	3	30	12 48	0	0
11	371	31.169	44.6	71	5	3	30	12 48	0	0
12	372	32.237	44.1	72	19	3	30	12 48	0	0
13	373	33.078	43.4	73	-25	3	30	12 48	0	0
14	374	34.083	42.7	74	3	1	30	12 48	0	0
15	375	35.155	42.2	75	17	1	30	12 68	0	0
16	376	36.048	42.8	76	0	1	30	12 68	0	0
17	377	37.001	43.8	77	9	1	30	12 68	0	0
18	378	37.945	44.0	78	-3	1	30	12 68	0	0
19	380	39.753	46.3	79	7	1	30	12 88	0	0
20	379	38.887	45.4	80	15	1	30	12 88	0	0

FIELD DATA TABLE

Shot number 3 Shot point 15 Team 5
Shot time: 161: 7: 0: 0.009

Loc	Dist(km)	Azim	Unit	Chron	Chan	C1	C2	C3	Tape
1	381	40.632	81	-9	1	30	12	48	0
2	382	41.420	82	-3	1	30	12	48	0
3	383	42.375	83	10	1	30	12	48	0
4	384	43.417	84	-6	1	30	12	48	0
5	385	44.189	85	4	1	30	12	48	0
6	386	45.198	86	-2	1	30	12	48	0
7	387	46.214	87	1	1	30	12	48	4
8	388	47.244	88	11	1	30	12	48	4
9	389	48.261	89	-2	1	30	12	48	0
10	390	49.226	90	5	1	30	12	48	0
11	391	50.236	91	8	1	30	12	48	0
12	392	51.283	92	0	1	30	12	68	0
13	393	52.641	93	4	1	30	12	68	0
14	394	54.022	94	10	1	30	12	68	0
15	395	54.988	95	0	1	30	12	68	0
16	396	55.584	96	-9	1	30	12	68	0
17	397	56.488	97	1	1	30	12	68	0
18	398	57.291	98	-17	3	12	12	12	0
19	399	58.468	99	10	1	30	12	48	0
20	400	59.634	100	7	1	30	12	48	0

FIELD DATA TABLE

Shot number 4 Shot point 16 Team 1
Shot time: 161: 7: 2: 0.010

Loc	Dist(km)	Azim	Unit	Chron	Chan	C1	C2	C3	Tape
1	301	109.502	234.4	1	10	2	30	12	88
2	302	109.085	234.1	2	8	2	30	12	88
3	303	108.622	233.4	3	5	2	30	12	68
4	304	107.282	233.0	4	-18	1	30	12	48
5	305	106.335	233.3	5	8	2	30	12	48
6	306	105.236	233.4	6	4	2	30	12	48
7	307	104.693	233.4	7	-2	2	30	12	48
8	308	104.007	233.6	8	9	2	30	12	48
9	309	102.738	233.4	9	12	2	30	12	48
10	310	101.502	233.1	10	2	2	30	12	48
11	311	100.693	232.8	11	-31	2	30	12	48
12	312	99.771	232.7	12	3	2	30	12	48
13	313	98.828	232.4	13	4	2	30	12	48
14	314	97.537	232.5	14	-12	2	30	12	48
15	315	156.336	237.4	15	0	2	30	12	88
16	316	95.348	233.4	16	-3	2	30	12	48
17	317	94.621	233.5	17	12	2	30	12	48
18	318	93.772	233.6	18	-11	2	30	12	48
19	319	92.527	234.0	19	16	3	30	12	48
20	320	91.763	234.0	20	-3	1	30	12	48

FIELD DATA TABLE

Shot number 3 Shot point 15 Team 6
Shot time: 161: 7: 0: 0.009

Loc	Dist(km)	Azim	Unit	Chron	Chan	C1	C2	C3	Tape
1	401	60.586	60.2	101	23	1	30	12	48
2	402	61.447	59.7	102	15	2	30	12	48
3	403	64.442	57.4	103	3	2	30	12	48
4	404	63.319	58.3	104	-3	1	30	12	48
5	405	65.325	56.9	105	33	1	30	12	48
6	406	66.466	56.5	106	0	1	30	12	48
7	407	67.243	56.3	107	36	1	30	12	48
8	408	68.378	56.2	108	2	1	30	12	48
9	409	69.468	56.1	109	7	1	30	12	48
10	410	70.436	55.8	110	24	3	30	12	48
11	411	71.313	54.7	111	59	1	30	12	68
12	412	72.459	53.8	112	12	1	30	12	88
13	413	79.928	50.5	113	-6	1	30	12	48
14	414	84.641	52.7	114	0	1	30	12	48
15	415	90.314	54.5	115	10	2	30	12	48
16	416	96.542	50.5	116	35	2	30	12	48
17	417	102.567	48.4	117	9	1	30	12	48
18	418	109.212	47.1	118	17	1	30	12	48
19	419	115.299	47.7	119	7	1	30	12	48
20	420	123.691	47.2	120	3	1	30	12	48

FIELD DATA TABLE

Shot number 4 Shot point 16 Team 2
Shot time: 161: 7: 2: 0.010

Loc	Dist(km)	Azim	Unit	Chron	Chan	C1	C2	C3	Tape
1	321	90.889	234.4	21	-2	1	30	12	48
2	322	89.653	234.7	22	6	2	30	12	48
3	323	88.517	235.0	23	11	2	30	12	48
4	324	87.319	235.4	24	0	2	30	12	48
5	325	86.573	234.9	25	5	2	30	12	68
6	326	85.917	235.0	26	2	2	30	12	68
7	327	84.474	234.4	27	29	2	30	12	88
8	328	83.723	234.1	28	-46	2	30	12	88
9	329	82.859	234.0	29	5	3	30	12	68
10	330	81.890	233.8	30	3	2	30	12	68
11	331	80.583	234.0	31	4	1	30	12	48
12	332	79.770	234.0	32	18	1	30	12	48
13	333	78.952	233.6	33	14	1	30	12	48
14	334	78.496	233.3	34	6	2	30	12	48
15	335	77.213	233.7	35	-15	2	30	12	48
16	336	76.099	233.9	36	2	1	30	12	48
17	337	74.966	233.9	37	1	1	30	12	68
18	338	74.194	234.0	38	2	2	30	12	68
19	339	72.990	233.8	39	1	1	30	12	88
20	340	72.322	233.9	40	4	2	30	12	88

FIELD DATA TABLE

Shot number 4 Shot point 16 Team 3
Shot time: 161: 7: 2: 0.010

Loc	Dist(km)	Azim	Unit	Chron	Chan	C1	C2	C3	Tape grade
1	341	70.856	234.6	41	-7	2	30	12 68	0
2	342	69.747	235.4	42	4	1	30	12 48	0
3	343	68.977	235.8	43	1	1	30	12 48	0
4	344	68.024	236.3	44	8	2	30	12 48	0
5	345	67.062	237.0	45	1	1	30	12 48	0
6	346	66.125	237.6	46	2	1	30	12 48	0
7	347	64.953	237.9	47	-3	1	30	12 48	0
8	348	63.750	238.1	48	0	1	30	12 48	0
9	349	62.997	237.9	49	1	1	30	12 48	0
10	350	62.040	237.6	50	-12	1	30	12 48	0
11	351	61.042	237.4	51	9	1	30	12 48	0
12	352	59.952	236.9	52	-4	1	30	12 48	0
13	353	59.070	237.1	53	6	1	30	12 48	0
14	354	58.290	237.5	54	-3	1	30	12 68	0
15	355	57.553	238.1	55	6	2	30	12 68	0
16	356	56.631	238.9	56	11	1	30	12 68	0
17	357	56.067	239.6	57	7	1	30	12 68	0
18	358	55.098	239.8	58	7	2	30	12 88	0
19	359	54.211	239.2	59	0	2	30	12 88	0
20	360	53.074	239.8	60	-3	1	30	12 88	0

FIELD DATA TABLE

Shot number 4 Shot point 16 Team 5
Shot time: 161: 7: 2: 0.010

Loc	Dist(km)	Azim	Unit	Chron	Chan	C1	C2	C3	Tape grade
1	361	32.308	242.0	81	-9	1	30	12 48	0
2	362	31.353	240.9	82	-3	1	30	12 48	0
3	363	30.225	239.3	83	10	3	30	12 48	0
4	364	29.070	237.8	84	-6	1	30	12 48	0
5	365	28.259	237.1	85	4	1	30	12 48	0
6	366	27.210	235.9	86	-2	1	30	12 48	0
7	367	26.174	234.6	87	1	3	30	12 48	0
8	368	25.147	233.3	88	11	1	30	12 48	4
9	369	24.160	231.6	89	-2	1	30	12 48	0
10	390	23.259	229.8	90	5	3	30	12 48	0
11	391	22.359	227.7	91	8	3	30	12 48	0
12	392	21.622	223.6	92	0	1	30	12 68	0
13	393	20.295	222.8	93	4	3	30	12 68	0
14	394	19.029	221.1	94	10	1	30	12 88	0
15	395	18.225	219.2	95	0	3	30	12 68	0
16	396	17.884	216.8	96	-9	1	30	12 68	0
17	397	17.245	214.2	97	1	3	30	12 68	0
18	398	16.730	211.7	98	-17	1	12	12 12	0
19	399	15.760	209.4	99	10	3	30	12 48	0
20	400	14.762	207.1	100	7	3	30	12 48	0

FIELD DATA TABLE

Shot number 4 Shot point 16 Team 4
Shot time: 161: 7: 2: 0.010

Loc	Dist(km)	Azim	Unit	Chron	Chan	C1	C2	C3	Tape grade
1	361	52.359	240.1	61	13	2	30	12 68	0
2	362	51.230	240.7	62	1	2	30	12 48	0
3	363	50.181	240.9	63	7	1	30	12 48	0
4	364	49.326	240.9	64	25	1	30	12 48	0
5	365	48.228	241.1	65	-5	1	30	12 48	0
6	366	47.207	241.2	66	15	1	30	12 48	0
7	367	46.243	241.3	67	0	1	30	12 48	0
8	368	44.758	241.2	68	-4	1	30	12 48	12
9	369	44.180	241.2	69	2	2	30	12 48	16
10	370	43.272	240.8	70	39	1	30	12 48	0
11	371	41.876	240.6	71	5	1	30	12 48	0
12	372	40.925	241.4	72	19	1	30	12 48	0
13	373	40.232	242.3	73	-25	1	30	12 48	0
14	374	39.424	243.3	74	3	1	30	12 48	0
15	375	38.523	244.3	75	17	1	30	12 68	0
16	376	37.569	244.3	76	0	1	30	12 68	0
17	377	36.461	243.9	77	9	1	30	12 68	0
18	378	35.516	244.2	78	-3	1	30	12 88	0
19	380	33.332	242.7	79	7	1	30	12 88	0
20	379	34.339	243.3	80	15	1	30	12 88	0

FIELD DATA TABLE

Shot number 4 Shot point 16 Team 6
Shot time: 161: 7: 2: 0.010

Loc	Dist(km)	Azim	Unit	Chron	Chan	C1	C2	C3	Tape grade
1	401	13.924	205.3	101	23	3	30	12 48	0
2	402	12.926	204.9	102	15	2	30	12 48	0
3	403	9.052	207.4	103	3	3	30	12 48	0
4	404	10.510	206.1	104	-3	3	30	12 48	0
5	405	8.018	207.6	105	33	3	30	12 48	0
6	406	6.785	206.4	106	0	3	30	12 48	0
7	407	5.967	205.1	107	36	3	30	12 48	0
8	408	4.987	199.0	108	2	3	30	12 48	0
9	409	4.051	191.5	109	7	3	30	12 48	0
10	410	3.181	183.1	110	24	3	30	12 48	0
11	411	1.585	187.4	111	59	3	30	12 68	0
12	412	0.079	29.3	112	12	3	30	12 88	0
13	413	8.963	23.2	113	-6	3	30	12 48	0
14	414	12.647	46.2	114	0	3	30	12 48	0
15	415	18.251	57.2	115	10	1	30	12 48	0
16	416	24.978	41.1	116	35	1	30	12 48	0
17	417	31.652	36.0	117	9	3	30	12 48	3
18	418	38.688	34.6	118	17	3	30	12 48	0
19	419	44.450	37.9	119	7	3	30	12 48	1
20	420	52.958	38.2	120	3	1	30	12 48	0

FIELD DATA TABLE

Shot number 5 Shot point 27 Team 1
Shot time: 161: 7: 4: 0.012

Loc	Dist(km)	Azim	Unit	Chron	Chan	C1	C2	C3	Tape grade
1	301	75.090	229.8	1	10	2	30	12 88	0
2	302	74.717	229.3	2	8	2	30	12 88	0
3	303	74.363	228.3	3	5	2	30	12 68	0
4	304	73.085	227.6	4	-18	2	30	12 48	0
5	305	72.095	228.0	5	8	2	30	12 48	0
6	306	70.979	228.1	6	4	2	30	12 48	0
7	307	70.435	228.0	7	-2	2	30	12 48	1
8	308	69.729	228.2	8	9	2	30	12 48	29
9	309	68.483	227.9	9	12	2	30	12 48	0
10	310	67.315	227.2	10	2	2	30	12 48	0
11	311	66.551	226.8	11	-31	2	30	12 48	0
12	312	65.656	226.5	12	3	2	30	12 48	0
13	313	64.759	226.0	13	4	2	30	12 48	0
14	314	63.457	226.0	14	-12	2	30	12 48	0
15	315	62.246	225.4	15	0	2	30	12 88	0
16	316	61.128	227.1	16	-3	2	30	12 48	0
17	317	60.380	227.2	17	12	2	30	12 48	0
18	318	59.516	227.3	18	-11	2	30	12 48	0
19	319	58.198	227.9	19	16	2	30	12 48	0
20	320	57.443	227.7	20	-3	1	30	12 48	0

FIELD DATA TABLE

Shot number 5 Shot point 27 Team 3
Shot time: 161: 7: 4: 0.012

Loc	Dist(km)	Azim	Unit	Chron	Chan	C1	C2	C3	Tape grade
1	341	36.326	225.2	41	-7	2	30	12 68	0
2	342	35.075	226.5	42	4	1	30	12 48	0
3	343	34.244	227.1	43	1	1	30	12 48	0
4	344	33.206	228.0	44	8	2	30	12 48	0
5	345	32.151	229.0	45	1	2	30	12 48	0
6	346	31.136	230.0	46	2	1	30	12 48	0
7	347	29.929	230.4	47	-3	1	30	12 48	0
8	348	28.702	230.6	48	0	2	30	12 48	0
9	349	27.980	230.1	49	1	1	30	12 48	0
10	350	27.086	229.0	50	-12	2	30	12 48	0
11	351	26.134	228.2	51	9	1	30	12 48	0
12	352	25.141	226.7	52	-4	2	30	12 48	0
13	353	24.245	226.7	53	6	1	30	12 48	0
14	354	23.402	227.4	54	-3	1	30	12 48	0
15	355	22.570	228.7	55	6	2	30	12 68	0
16	356	21.546	230.2	56	11	1	30	12 68	0
17	357	20.886	232.0	57	7	1	30	12 68	0
18	358	19.905	232.0	58	7	2	30	12 88	0
19	359	19.110	230.0	59	0	1	30	12 88	0
20	360	17.907	231.1	60	-3	1	30	12 88	0

FIELD DATA TABLE

Shot number 5 Shot point 27 Team 2
Shot time: 161: 7: 4: 0.012

Loc	Dist(km)	Azim	Unit	Chron	Chan	C1	C2	C3	Tape grade
1	321	56.514	228.2	21	-2	2	30	12 48	0
2	322	55.225	228.6	22	6	3	30	12 48	0
3	323	54.047	229.0	23	11	3	30	12 48	12
4	324	52.797	229.4	24	0	2	30	12 48	12
5	325	52.118	228.7	25	5	2	30	12 68	0
6	326	51.462	228.6	26	2	2	30	12 68	0
7	327	50.122	227.4	27	30	2	30	12 88	0
8	328	49.421	226.9	28	-47	2	30	12 88	3
9	329	48.582	226.5	29	5	2	30	12 68	12
10	330	47.596	226.0	30	3	2	30	12 68	0
11	331	46.310	226.3	31	4	1	30	12 48	0
12	332	45.232	225.1	32	18	3	30	12 48	3
13	333	44.519	225.1	33	15	1	30	12 48	0
14	334	44.115	224.6	34	6	3	30	12 48	12
15	335	42.780	224.9	35	-15	2	30	12 48	12
16	336	41.630	225.2	36	2	1	30	12 48	0
17	337	40.504	225.0	37	1	1	30	12 68	0
18	338	39.740	224.8	38	2	2	30	12 68	0
19	339	38.590	224.2	39	1	2	30	12 88	0
20	340	37.904	224.3	40	4	2	30	12 88	0

FIELD DATA TABLE

Shot number 5 Shot point 27 Team 4
Shot time: 161: 7: 4: 0.012

Loc	Dist(km)	Azim	Unit	Chron	Chan	C1	C2	C3	Tape grade
1	361	17.152	231.8	61	13	1	30	12 68	0
2	362	15.970	232.9	62	1	1	30	12 48	0
3	363	14.904	233.1	63	7	1	30	12 48	0
4	364	14.051	232.8	64	25	3	30	12 48	0
5	365	12.942	232.9	65	-5	3	30	12 48	0
6	366	11.924	232.4	66	15	3	30	12 48	0
7	367	10.964	232.0	67	0	1	30	12 48	0
8	368	9.832	45.2	68	-4	1	30	12 48	0
9	369	8.947	229.4	69	2	2	30	12 48	16
10	370	8.138	225.9	70	39	3	30	12 48	0
11	371	6.826	222.1	71	5	3	30	12 48	0
12	372	5.752	224.4	72	19	3	30	12 48	0
13	373	4.927	238.6	73	-25	3	30	12 48	0
14	374	4.000	236.1	74	3	3	30	12 48	0
15	375	3.069	246.0	75	17	3	30	12 68	0
16	376	2.116	247.1	76	0	3	30	12 68	0
17	377	1.012	236.8	77	9	3	30	12 68	0
18	378	0.070	274.5	78	-3	3	30	12 88	0
19	380	2.291	85.1	79	7	3	30	12 88	0
20	379	1.230	88.1	80	15	3	30	12 88	0

FIELD DATA TABLE

Shot number 5 Shot point 27 Team 5
Shot time: 161: 7: 4; 0.012

Loc	Dist(km)	Azim	Unit	Chron	Chan	C1	C2	C3	Tape grade
1	381	3.398	84.9	81	-9	3	30	12 48	0
2	382	4.528	87.3	82	-3	3	30	12 48	0
3	383	5.929	89.6	83	10	3	30	12 48	0
4	384	7.321	90.1	84	-6	3	30	12 48	29
5	385	8.202	89.2	85	4	3	30	12 48	0
6	386	9.390	88.6	86	-2	3	30	12 48	0
7	387	10.590	88.3	87	1	3	30	12 48	0
8	388	11.781	87.9	88	11	3	30	12 48	4
9	389	12.998	87.9	89	-2	3	30	12 48	0
10	390	14.175	88.1	90	5	3	30	12 48	0
11	391	15.417	88.5	91	8	3	30	12 48	0
12	392	17.023	90.6	92	0	1	30	12 68	0
13	393	18.154	88.1	93	4	1	30	12 68	0
14	394	19.459	86.6	94	10	1	30	12 68	0
15	395	20.473	86.2	95	0	1	30	12 68	0
16	396	21.270	86.9	96	-9	1	30	12 68	0
17	397	22.277	86.9	97	1	3	30	12 68	0
18	398	23.187	86.9	98	-17	2	12	12 12	0
19	399	24.287	85.9	99	10	3	30	12 48	0
20	400	25.334	84.7	100	7	3	30	12 48	0

FIELD DATA TABLE

Shot number 6 Shot point 23 Team 1
Shot time: 161: 7: 6; 0.008

Loc	Dist(km)	Azim	Unit	Chron	Chan	C1	C2	C3	Tape grade
1	301	110.628	64.3	1	10	1	30	12 88	0
2	302	111.158	64.6	2	8	1	30	12 88	0
3	303	111.907	65.2	3	5	1	30	12 68	0
4	304	113.376	65.4	4	-18	1	30	12 48	0
5	305	114.181	65.1	5	8	1	30	12 48	0
6	306	115.202	64.8	6	4	1	30	12 48	0
7	307	115.732	64.8	7	-2	1	30	12 48	1
8	308	116.348	64.6	8	9	1	30	12 48	29
9	309	117.639	64.6	9	12	1	30	12 48	0
10	310	119.003	64.8	10	2	1	30	12 48	0
11	311	119.894	64.9	11	-31	1	30	12 48	0
12	312	120.851	64.9	12	3	1	30	12 48	0
13	313	121.868	65.0	13	4	1	30	12 48	0
14	314	123.088	64.8	14	-12	1	30	12 48	0
15	315	63.397	64.3	15	0	1	30	12 88	0
16	316	124.906	64.0	16	-3	1	30	12 48	0
17	317	125.571	63.8	17	12	1	30	12 48	0
18	318	126.370	63.7	18	-11	1	30	12 48	0
19	319	127.445	63.3	19	16	1	30	12 48	0
20	320	128.211	63.2	20	-3	1	30	12 48	0

FIELD DATA TABLE

Shot number 5 Shot point 27 Team 6
Shot time: 161: 7: 4; 0.012

Loc	Dist(km)	Azim	Unit	Chron	Chan	C1	C2	C3	Tape grade
1	401	26.167	83.7	101	23	3	30	12 48	0
2	402	26.764	81.9	102	15	2	30	12 48	0
3	403	28.743	75.0	103	3	2	30	12 48	0
4	404	27.975	77.5	104	-3	1	30	12 48	0
5	405	29.432	73.5	105	33	1	30	12 48	0
6	406	30.397	72.0	106	0	1	30	12 48	0
7	407	31.071	71.1	107	36	1	30	12 48	0
8	408	32.151	70.5	108	2	1	30	12 48	0
9	409	33.169	69.7	109	7	1	30	12 48	0
10	410	34.041	68.8	110	24	1	30	12 48	0
11	411	34.618	66.3	111	59	1	30	12 68	0
12	412	35.521	64.1	112	12	1	30	12 88	0
13	413	42.608	56.2	113	-6	1	30	12 48	0
14	414	47.632	59.4	114	0	1	30	12 48	0
15	415	53.608	61.8	115	10	2	30	12 48	0
16	416	59.212	54.6	116	35	1	30	12 48	0
17	417	65.045	50.8	117	9	1	30	12 48	3
18	418	71.631	48.7	118	17	1	30	12 48	0
19	419	77.765	49.4	119	8	1	30	12 48	1
20	420	85.870	48.5	120	3	2	30	12 48	0

FIELD DATA TABLE

Shot number 6 Shot point 23 Team 2
Shot time: 161: 7: 6; 0.008

Loc	Dist(km)	Azim	Unit	Chron	Chan	C1	C2	C3	Tape grade
1	321	128.969	62.9	21	-2	1	30	12 48	0
2	322	130.094	62.6	22	6	1	30	12 48	0
3	323	131.143	62.3	23	11	1	30	12 48	12
4	324	132.246	62.0	24	0	1	30	12 48	12
5	325	133.081	62.3	25	5	1	30	12 68	0
6	326	133.728	62.2	26	2	1	30	12 68	0
7	327	135.296	62.5	27	30	1	30	12 88	0
8	328	136.106	62.6	28	-47	1	30	12 88	3
9	329	136.988	62.6	29	5	1	30	12 68	12
10	330	138.054	62.7	30	3	1	30	12 68	0
11	331	139.218	62.5	31	4	1	30	12 48	0
12	332	140.284	62.4	32	18	1	30	12 48	3
13	333	141.211	62.6	33	15	1	30	12 48	0
14	334	141.716	62.7	34	6	1	30	12 48	12
15	335	142.890	62.5	35	-15	1	30	12 48	12
16	336	143.926	62.3	36	2	1	30	12 48	0
17	337	145.032	62.2	37	1	1	30	12 68	0
18	338	145.788	62.1	38	1	1	30	12 68	0
19	339	147.011	62.1	39	1	1	30	12 68	0
20	340	147.639	62.0	40	4	1	30	12 88	0

FIELD DATA TABLE

Shot number 6 Shot point 23 Team 5
Shot time: 161: 7: 6: 0.008

Loc	Dist(km)	Azim	Unit	Chron	Chan	C1	C2	C3	Tape grade
1	381	186.832	81	-9	1	30	12	48	0
2	382	187.774	82	-3	1	30	12	48	0
3	383	188.908	83	10	1	30	12	48	0
4	384	190.091	84	-6	1	30	12	48	0
5	385	190.922	85	4	1	30	12	48	0
6	386	192.011	86	-2	1	30	12	48	0
7	387	193.103	87	1	1	30	12	48	0
8	388	194.198	88	11	1	30	12	48	4
9	389	195.283	89	-2	1	30	12	48	0
10	390	196.311	90	5	1	30	12	48	0
11	391	197.382	91	8	1	30	12	48	0
12	392	198.530	92	0	1	30	12	68	0
13	393	199.875	93	4	1	30	12	68	0
14	394	201.262	94	10	1	30	12	88	0
15	395	202.245	95	0	1	30	12	68	0
16	396	202.871	96	-9	1	30	12	68	0
17	397	203.793	97	1	1	30	12	68	0
18	398	204.612	98	-17	2	12	12	12	0
19	399	205.788	99	10	1	30	12	48	0
20	400	206.948	100	7	1	30	12	48	0

Shot number 6 Shot point 23 Team 3
Shot time: 161: 7: 6: 0.008

Loc	Dist(km)	Azim	Unit	Chron	Chan	C1	C2	C3	Tape grade
1	341	148.952	41	-7	1	30	12	68	0
2	342	149.907	42	4	1	30	12	48	0
3	343	150.611	43	1	1	30	12	48	0
4	344	151.481	44	9	1	30	12	48	0
5	345	152.366	45	1	1	30	12	48	0
6	346	153.244	46	2	1	30	12	48	0
7	347	154.385	47	-3	1	30	12	48	0
8	348	155.566	48	0	1	30	12	48	0
9	349	156.326	49	1	1	30	12	48	0
10	350	157.302	50	-12	1	30	12	48	0
11	351	158.311	51	9	1	30	12	48	0
12	352	159.433	52	-4	1	30	12	48	0
13	353	160.297	53	6	1	30	12	48	0
14	354	161.039	54	-3	1	30	12	48	0
15	355	161.731	55	6	1	30	12	68	0
16	356	162.614	56	11	2	30	12	68	0
17	357	163.155	57	7	1	30	12	68	0
18	358	164.118	58	7	2	30	12	88	0
19	359	165.015	59	0	1	30	12	88	0
20	360	166.135	60	-3	1	30	12	88	0

FIELD DATA TABLE

Shot number 6 Shot point 23 Team 6
Shot time: 161: 7: 6: 0.008

Loc	Dist(km)	Azim	Unit	Chron	Chan	C1	C2	C3	Tape grade
1	401	207.891	101	23	1	30	12	48	0
2	402	208.725	102	15	2	30	12	48	12
3	403	211.549	103	4	2	30	12	48	0
4	404	210.500	104	-3	1	30	12	48	0
5	405	212.385	105	33	1	30	12	48	0
6	406	213.478	106	0	1	30	12	48	0
7	407	214.224	107	36	2	30	12	48	0
8	408	215.343	108	2	1	30	12	48	0
9	409	216.410	109	7	2	30	12	48	0
10	410	217.342	110	24	3	30	12	48	0
11	411	218.080	111	59	1	30	12	68	0
12	412	219.084	112	12	1	30	12	88	0
13	413	226.146	113	-6	2	30	12	48	0
14	414	231.226	114	0	1	30	12	48	0
15	415	237.165	115	10	2	30	12	48	0
16	416	242.562	116	35	2	30	12	48	0
17	417	247.954	117	9	2	30	12	48	3
18	418	254.115	118	17	2	30	12	48	0
19	419	260.299	119	8	2	30	12	48	1
20	420	268.385	120	3	2	30	12	48	0

FIELD DATA TABLE

Shot number 6 Shot point 23 Team 4
Shot time: 161: 7: 6: 0.008

Loc	Dist(km)	Azim	Unit	Chron	Chan	C1	C2	C3	Tape grade
1	361	166.843	61	13	1	30	12	68	0
2	362	167.967	62	1	1	30	12	48	0
3	363	169.013	63	7	1	30	12	48	0
4	364	169.866	64	25	3	30	12	48	0
5	365	170.961	65	-5	1	30	12	48	0
6	366	171.980	66	15	1	30	12	48	0
7	367	172.940	67	0	1	30	12	48	0
8	368	175.438	68	-4	2	30	12	48	12
9	369	174.995	69	2	1	30	12	48	0
10	370	175.897	70	39	1	30	12	48	0
11	371	177.288	71	5	1	30	12	48	0
12	372	178.240	72	19	1	30	12	48	0
13	373	178.946	73	-25	1	30	12	48	0
14	374	179.785	74	3	1	30	12	48	0
15	375	180.724	75	17	1	30	12	68	0
16	376	181.673	76	0	1	30	12	68	0
17	377	182.756	77	9	1	30	12	68	0
18	378	183.706	78	-3	1	30	12	88	0
19	380	185.828	79	7	1	30	12	88	0
20	379	184.842	80	15	1	30	12	88	0

FIELD DATA TABLE

Shot number 7 Shot point 25 Team 1
Shot time: 161: 9: 0: 0.013

Loc	Dist(km)	Azim	Unit	Chron	Chan	C1	C2	C3	Tape	grade
1	301	24.716	236.1	1	12	30	12	88	12	0
2	302	24.279	234.7	2	10	2	30	12	88	0
3	303	23.815	231.5	3	6	2	30	12	68	0
4	304	22.495	229.6	4	-20	2	30	12	48	0
5	305	21.526	230.8	5	9	2	30	12	48	0
6	306	20.419	231.3	6	5	2	30	12	48	0
7	307	19.873	231.3	7	-3	30	12	48	1	0
8	308	19.180	231.9	8	11	2	30	12	48	0
9	309	17.913	231.1	9	14	2	30	12	48	0
10	310	16.709	228.5	10	2	2	30	12	48	0
11	311	15.935	226.8	11	-36	2	30	12	48	0
12	312	15.042	225.5	12	4	2	30	12	48	0
13	313	14.159	223.9	13	5	2	30	12	48	0
14	314	12.859	223.1	14	-14	2	30	12	88	0
15	315	12.150	241.5	15	1	2	30	12	48	0
16	316	10.519	228.6	16	-3	2	30	12	48	0
17	317	9.777	229.6	17	14	1	30	12	48	29
18	318	8.919	230.3	18	-12	1	30	12	48	0
19	319	7.664	235.4	19	18	1	30	12	48	0
20	320	6.895	234.9	20	-4	30	12	48	3/29	0

FIELD DATA TABLE

Shot number 7 Shot point 25 Team 3
Shot time: 161: 9: 0: 0.013

Loc	Dist(km)	Azim	Unit	Chron	Chan	C1	C2	C3	Tape	grade
1	341	14.343	50.8	41	-8	2	30	12	68	0
2	342	15.541	47.3	42	5	2	30	12	48	0
3	343	16.372	46.0	43	2	2	30	12	48	0
4	344	17.427	44.4	44	10	2	30	12	48	0
5	345	18.527	42.8	45	1	2	30	12	48	0
6	346	19.601	41.5	46	3	2	30	12	48	0
7	347	20.824	41.5	47	-4	2	30	12	48	0
8	348	22.054	41.7	48	0	2	30	12	48	0
9	349	22.731	42.7	49	1	2	30	12	48	0
10	350	23.568	44.2	50	-14	2	30	12	48	0
11	351	24.494	45.2	51	10	2	30	12	48	0
12	352	25.474	46.8	52	-5	2	30	12	48	0
13	353	26.370	46.8	53	7	2	30	12	48	0
14	354	27.214	46.2	54	-4	2	30	12	48	12
15	355	28.063	45.2	55	7	2	30	12	68	0
16	356	29.130	44.2	56	13	2	30	12	68	0
17	357	29.866	43.1	57	8	2	30	12	68	0
18	358	30.839	43.3	58	9	2	30	12	88	0
19	359	31.548	44.8	59	-2	2	30	12	88	0
20	360	32.778	44.4	60	-3	2	30	12	88	0

FIELD DATA TABLE

Shot number 7 Shot point 25 Team 2
Shot time: 161: 9: 0: 0.013

Loc	Dist(km)	Azim	Unit	Chron	Chan	C1	C2	C3	Tape	grade
1	321	6.060	240.4	21	-2	1	30	12	48	0
2	322	4.937	248.3	22	7	1	30	12	48	0
3	323	4.006	258.6	23	12	30	12	48	12	0
4	324	3.283	276.1	24	0	30	12	48	12	0
5	325	2.289	276.3	25	5	1	30	12	68	0
6	326	1.861	290.3	26	3	1	30	12	68	0
7	327	0.771	356.5	27	34	1	30	12	88	0
8	328	1.198	41.9	28	-53	1	30	12	88	0
9	329	2.042	51.7	29	6	1	30	12	68	12
10	330	3.084	57.9	30	3	1	30	12	68	0
11	331	4.326	51.9	31	4	3	30	12	48	0
12	332	5.412	52.2	32	21	1	30	12	48	3
13	333	6.259	58.8	33	17	1	30	12	48	0
14	334	6.750	61.1	34	7	30	12	48	12	0
15	335	7.981	56.6	35	-18	30	12	48	12	0
16	336	9.082	54.1	36	3	30	12	48	0	0
17	337	10.215	53.8	37	2	2	30	12	68	0
18	338	10.986	53.8	38	2	2	30	12	68	0
19	339	12.194	54.9	39	1	2	30	12	88	0
20	340	12.858	54.0	40	4	2	30	12	88	0

FIELD DATA TABLE

Shot number 7 Shot point 25 Team 4
Shot time: 161: 9: 0: 0.013

Loc	Dist(km)	Azim	Unit	Chron	Chan	C1	C2	C3	Tape	grade
1	361	33.555	44.2	61	14	2	30	12	68	0
2	362	34.770	43.9	62	1	2	30	12	48	0
3	363	35.832	44.1	63	8	2	30	12	48	0
4	364	36.665	44.4	64	26	2	30	12	48	0
5	365	37.766	44.6	65	-6	2	30	12	48	0
6	366	38.761	45.0	66	16	2	30	12	48	0
7	367	39.704	45.3	67	0	2	30	12	48	0
8	368	44.257	45.8	68	-4	1	30	12	48	0
9	369	41.677	46.2	69	2	2	30	12	48	3
10	370	42.479	46.9	70	42	2	30	12	48	0
11	371	43.818	47.5	71	5	2	30	12	48	0
12	372	44.870	47.1	72	21	2	30	12	48	0
13	373	45.690	46.5	73	-26	2	30	12	48	0
14	374	46.669	46.0	74	3	2	30	12	48	0
15	375	47.722	45.5	75	19	2	30	12	68	0
16	376	48.633	45.9	76	0	2	30	12	68	0
17	377	49.617	46.5	77	10	2	30	12	68	0
18	378	50.568	46.7	78	-3	2	30	12	88	0
19	380	52.439	48.3	79	7	2	30	12	88	0
20	379	51.549	47.7	80	16	2	30	12	88	0

FIELD DATA TABLE

Shot number 7 Shot point 25 Team 5
Shot time: 161: 9: 0: 0.013

Loc	Dist(km)	Azim	Unit	Chron	Chan	C1	C2	C3	Tape grade
1	381	53.340	49.0	81	-11	2	30	12 48	0
2	382	54.153	49.9	82	-4	2	30	12 48	0
3	383	55.132	51.0	83	11	2	30	12 48	0
4	384	56.191	51.9	84	-6	2	30	12 48	0
5	385	56.969	52.4	85	5	2	30	12 48	0
6	386	57.985	53.0	86	-2	2	30	12 48	0
7	387	59.006	53.6	87	1	2	30	12 48	0
8	388	60.039	54.2	88	12	2	30	12 48	12
9	389	61.058	54.8	89	-2	2	30	12 48	0
10	390	62.022	55.5	90	6	2	30	12 48	0
11	391	63.029	56.2	91	9	2	30	12 48	0
12	392	64.065	57.4	92	0	2	30	12 68	0
13	393	65.424	57.4	93	5	2	30	12 68	12
14	394	66.803	57.6	94	12	2	30	12 68	0
15	395	67.766	57.9	95	0	2	30	12 68	0
16	396	68.354	58.4	96	-10	2	30	12 68	0
17	397	69.252	58.8	97	2	2	30	12 68	7
18	398	70.048	59.1	98	-19	2	12	12 12	0
19	399	71.224	59.3	99	11	2	30	12 48	0
20	400	72.390	59.3	100	8	2	30	12 48	0

FIELD DATA TABLE

Shot number 8 Shot point 28 Team 1
Shot time: 161: 9: 2: 0.013

Loc	Dist(km)	Azim	Unit	Chron	Chan	C1	C2	C3	Tape grade
1	301	91.076	237.2	1	12	2	30	12 88	0
2	302	90.630	236.8	2	10	2	30	12 88	0
3	303	90.103	236.0	3	6	2	30	12 68	0
4	304	88.732	235.6	4	-20	2	30	12 48	0
5	305	87.808	235.9	5	9	2	30	12 48	0
6	306	86.721	236.1	6	5	2	30	12 48	0
7	307	86.178	236.1	7	-3	2	30	12 48	1
8	308	85.505	236.3	8	11	2	30	12 48	0
9	309	84.226	236.2	9	14	2	30	12 48	0
10	310	82.956	235.8	10	2	2	30	12 48	0
11	311	82.126	235.5	11	-36	2	30	12 48	0
12	312	81.192	235.4	12	4	2	30	12 48	0
13	313	80.230	235.1	13	5	2	30	12 48	0
14	314	79.216	235.2	14	-14	2	30	12 48	0
15	315	138.209	239.6	15	1	2	30	12 88	0
16	316	77.097	236.4	16	-3	2	30	12 48	0
17	317	76.381	236.5	17	14	2	30	12 48	0
18	318	75.539	236.7	18	-12	2	30	12 48	0
19	319	74.336	237.3	19	18	2	30	12 48	0
20	320	73.566	237.3	20	-4	1	30	12 48	12

FIELD DATA TABLE

Shot number 7 Shot point 25 Team 6
Shot time: 161: 9: 0: 0.013

Loc	Dist(km)	Azim	Unit	Chron	Chan	C1	C2	C3	Tape grade
1	401	73.343	59.2	101	24	2	30	12 48	0
2	402	74.211	58.8	102	16	2	30	12 48	0
3	403	77.231	57.0	103	4	1	30	12 48	0
4	404	76.100	57.7	104	-3	2	30	12 48	0
5	405	78.117	56.6	105	35	2	30	12 48	0
6	406	79.261	56.2	106	0	2	30	12 48	0
7	407	79.764	56.0	107	39	2	30	12 48	12
8	408	80.896	56.0	108	2	2	30	12 48	0
9	409	81.983	55.8	109	7	2	30	12 48	0
10	410	82.948	55.6	110	25	1	30	12 48	9
11	411	83.824	54.7	111	63	2	30	12 68	0
12	412	84.965	53.9	112	13	2	30	12 68	0
13	413	92.644	51.1	113	-6	2	30	12 48	0
14	414	97.383	52.9	114	0	1	30	12 48	0
15	415	103.066	54.5	115	11	2	30	12 48	0
16	416	109.255	51.0	116	37	2	30	12 48	0
17	417	115.236	49.1	117	10	2	30	12 48	0
18	418	121.845	47.9	118	18	2	30	12 48	0
19	419	127.948	48.4	119	8	2	30	12 48	1
20	420	136.321	47.8	120	3	2	30	12 48	0

FIELD DATA TABLE

Shot number 8 Shot point 28 Team 2
Shot time: 161: 9: 2: 0.013

Loc	Dist(km)	Azim	Unit	Chron	Chan	C1	C2	C3	Tape grade
1	321	72.725	237.8	21	-2	2	30	12 48	0
2	322	71.522	238.3	22	7	2	30	12 48	12
3	323	70.416	238.7	23	12	2	30	12 48	12
4	324	69.254	239.2	24	0	2	30	12 48	12
5	325	68.462	238.8	25	5	2	30	12 68	0
6	326	67.805	238.8	26	3	2	30	12 68	0
7	327	66.298	238.1	27	34	2	30	12 88	12
8	328	65.518	237.8	28	-53	2	30	12 88	0
9	329	64.641	237.7	29	6	2	30	12 68	12
10	330	63.590	237.5	30	3	2	30	12 68	0
11	331	62.367	237.9	31	4	2	30	12 48	0
12	332	61.283	238.0	32	21	2	30	12 48	0
13	333	60.418	237.4	33	17	2	30	12 48	0
14	334	59.942	237.2	34	7	2	30	12 48	12
15	335	58.693	237.7	35	-18	2	30	12 48	12
16	336	57.606	238.1	36	3	2	30	12 48	12
17	337	56.479	238.2	37	2	2	30	12 68	0
18	338	55.710	238.3	38	2	2	30	12 68	12
19	339	54.491	238.2	39	1	2	30	12 88	0
20	340	53.839	238.4	40	4	2	30	12 88	0

FIELD DATA TABLE

Shot number 8 Shot point 28 Team 3
Shot time: 161: 9: 2: 0.013

Loc	Dist(km)	Azim	Unit	Chron	Chan	C1	C2	C3	Tape grade
1	341	52.485	239.4	41	-8	2	30	12 68	0
2	342	51.431	240.6	42	5	2	30	12 48	0
3	343	50.709	241.2	43	2	2	30	12 48	0
4	344	49.827	242.1	44	10	2	30	12 48	0
5	345	48.948	243.1	45	1	2	30	12 48	0
6	346	48.091	244.0	46	3	2	30	12 48	0
7	347	46.968	244.6	47	-4	2	30	12 48	0
8	348	45.806	245.1	48	0	2	30	12 48	0
9	349	45.035	245.0	49	1	2	30	12 48	0
10	350	44.038	244.6	50	-14	2	30	12 48	0
11	351	43.018	244.5	51	10	2	30	12 48	0
12	352	41.875	244.0	52	-5	2	30	12 48	12
13	353	41.019	244.4	53	7	2	30	12 48	0
14	354	40.303	245.2	54	-4	2	30	12 68	0
15	355	39.662	246.2	55	7	2	30	12 68	0
16	356	38.859	247.5	56	13	2	30	12 68	0
17	357	38.416	248.7	57	8	2	30	12 68	0
18	358	37.484	249.2	58	9	2	30	12 88	0
19	359	36.514	248.5	59	-2	2	30	12 88	0
20	360	35.481	249.6	60	-3	2	30	12 88	0

FIELD DATA TABLE

Shot number 8 Shot point 28 Team 5
Shot time: 161: 9: 2: 0.013

Loc	Dist(km)	Azim	Unit	Chron	Chan	C1	C2	C3	Tape grade
1	381	15.940	267.2	81	-11	1	30	12 48	0
2	382	14.809	266.6	82	-4	1	30	12 48	0
3	383	13.419	265.5	83	11	1	30	12 48	0
4	384	12.037	264.7	84	-6	1	30	12 48	0
5	385	11.148	265.0	85	5	1	30	12 48	0
6	386	9.957	265.0	86	-2	1	30	12 48	0
7	387	8.755	265.0	87	1	1	30	12 48	0
8	388	7.562	265.0	88	12	1	30	12 48	4
9	389	6.347	264.5	89	-2	3	30	12 48	0
10	390	5.177	263.0	90	6	3	30	12 48	0
11	391	3.954	260.1	91	9	3	30	12 68	0
12	392	2.613	241.1	92	0	1	30	12 68	0
13	393	1.265	246.8	93	5	3	30	12 68	0
14	394	0.131	66.8	94	12	3	30	12 88	0
15	395	1.153	77.1	95	0	3	30	12 68	0
16	396	1.934	88.2	96	-10	1	30	12 68	0
17	397	2.941	87.5	97	-2	3	30	12 68	0
18	398	3.851	87.7	98	-19	2	12	12 12	0
19	399	4.963	82.5	99	11	1	30	12 48	0
20	400	6.053	78.2	100	8	1	30	12 48	0

FIELD DATA TABLE

Shot number 8 Shot point 28 Team 4
Shot time: 161: 9: 2: 0.013

Loc	Dist(km)	Azim	Unit	Chron	Chan	C1	C2	C3	Tape grade
1	361	34.836	250.4	61	14	2	30	12 68	0
2	362	33.815	251.5	62	2	2	30	12 48	0
3	363	32.822	252.2	63	8	2	30	12 48	0
4	364	31.993	252.6	64	26	2	30	12 48	0
5	365	30.955	253.3	65	-6	2	30	12 48	0
6	366	29.967	253.8	66	16	2	30	12 48	0
7	367	29.040	254.3	67	0	2	30	12 48	0
8	368	80.554	36.2	68	-4	2	30	12 48	0
9	369	27.016	255.2	69	2	2	30	12 48	3
10	370	26.053	255.0	70	42	2	30	12 48	0
11	371	24.677	255.6	71	5	2	30	12 48	0
12	372	23.912	257.4	72	21	2	30	12 48	0
13	373	23.418	259.3	73	-26	2	30	12 48	0
14	374	22.873	261.7	74	3	2	30	12 48	0
15	375	22.235	264.0	75	19	2	30	12 68	0
16	376	21.343	264.9	76	0	2	30	12 68	0
17	377	20.220	265.3	77	10	2	30	12 68	0
18	378	19.405	266.8	78	-3	2	30	12 88	0
19	380	17.047	267.0	79	7	2	30	12 88	0
20	379	18.106	266.7	80	16	2	30	12 88	0

FIELD DATA TABLE

Shot number 8 Shot point 28 Team 6
Shot time: 161: 9: 2: 0.013

Loc	Dist(km)	Azim	Unit	Chron	Chan	C1	C2	C3	Tape grade
1	401	6.942	75.0	101	24	1	30	12 48	0
2	402	7.678	69.7	102	16	1	30	12 48	0
3	403	10.590	53.2	103	4	2	30	12 48	9
4	404	9.426	58.4	104	-3	1	30	12 48	0
5	405	11.522	50.8	105	35	1	30	12 48	0
6	406	12.715	49.2	106	0	2	30	12 48	0
7	407	13.525	48.4	107	39	1	30	12 48	0
8	408	14.660	48.7	108	2	1	30	12 48	0
9	409	15.764	48.6	109	7	2	30	12 48	0
10	410	16.765	48.0	110	25	1	30	12 48	0
11	411	17.854	44.1	111	63	1	30	12 68	0
12	412	19.225	41.2	112	13	2	30	12 88	0
13	413	27.801	35.5	113	-6	2	30	12 48	0
14	414	31.768	43.3	114	0	2	30	12 48	0
15	415	37.050	49.1	115	11	2	30	12 48	0
16	416	44.125	41.2	116	37	2	30	12 48	0
17	417	50.743	38.0	117	10	2	30	12 48	0
18	418	57.741	36.8	118	18	2	30	12 48	0
19	419	63.569	38.9	119	8	2	30	12 48	1
20	420	72.079	39.0	120	3	2	30	12 48	0

FIELD DATA TABLE

Shot number 9 Shot point 26 Team 1
Shot time: 161: 9: 4: 0.012

Loc	Dist(km)	Azim	Unit	Chron	Chan	C1	C2	C3	Tape grade
1	301	55.204	228.9	1	12	2	30	12 88	0
2	302	54.840	228.3	2	10	2	30	12 88	0
3	303	54.513	226.8	3	6	2	30	12 68	0
4	304	53.255	225.9	4	-20	2	30	12 48	0
5	305	52.255	226.4	5	9	2	30	12 48	0
6	306	51.136	226.5	6	5	2	30	12 48	0
7	307	50.594	226.4	7	-3	3	30	12 48	1
8	308	49.883	226.6	8	11	2	30	12 48	0
9	309	48.648	226.1	9	14	2	30	12 48	0
10	310	47.506	225.1	10	2	2	30	12 48	0
11	311	46.761	224.4	11	-36	2	30	12 48	0
12	312	45.881	224.0	12	4	2	30	12 48	0
13	313	45.007	223.3	13	5	2	30	12 48	0
14	314	43.707	223.2	14	-14	2	30	12 48	0
15	315	41.468	236.1	15	1	2	30	12 88	0
16	316	41.330	224.6	16	-3	2	30	12 48	0
17	317	40.577	224.8	17	14	2	30	12 48	0
18	318	39.711	224.8	18	-12	1	30	12 48	0
19	319	38.370	225.7	19	18	1	30	12 48	0
20	320	37.622	225.4	20	-4	1	30	12 48	12

FIELD DATA TABLE

Shot number 9 Shot point 26 Team 3
Shot time: 161: 9: 4: 0.012

Loc	Dist(km)	Azim	Unit	Chron	Chan	C1	C2	C3	Tape grade
1	341	15.736	216.9	41	-8	1	30	12 68	0
2	342	15.388	219.2	42	5	1	30	12 48	0
3	343	14.520	220.1	43	2	1	30	12 48	0
4	344	13.430	221.8	44	10	1	30	12 48	0
5	345	12.323	224.0	45	1	3	30	12 48	0
6	346	11.269	226.3	46	3	3	30	12 48	0
7	347	10.053	226.9	47	-4	3	30	12 48	0
8	348	8.822	227.2	48	0	3	30	12 48	0
9	349	8.122	224.9	49	1	3	30	12 48	0
10	350	7.293	220.4	50	-14	3	30	12 48	0
11	351	6.425	215.8	51	10	3	30	12 48	0
12	352	5.651	207.1	52	-5	3	30	12 48	0
13	353	4.816	203.6	53	7	3	30	12 48	0
14	354	3.927	202.6	54	-4	3	30	12 48	0
15	355	2.962	204.5	55	7	3	30	12 68	0
16	356	1.787	208.0	56	13	3	30	12 68	0
17	357	0.986	228.4	57	8	3	30	12 68	0
18	358	0.037	148.1	58	9	3	30	12 88	0
19	359	1.081	93.9	59	-2	3	30	12 88	0
20	360	2.027	61.8	60	-3	3	30	12 88	0

FIELD DATA TABLE

Shot number 9 Shot point 26 Team 2
Shot time: 161: 9: 4: 0.012

Loc	Dist(km)	Azim	Unit	Chron	Chan	C1	C2	C3	Tape grade
1	321	36.677	226.0	21	-2	1	30	12 48	0
2	322	35.375	226.6	22	7	2	30	12 48	0
3	323	34.187	227.1	23	12	2	30	12 48	12
4	324	32.925	227.8	24	0	3	30	12 48	12
5	325	32.269	226.5	25	5	1	30	12 68	0
6	326	31.616	226.4	26	3	1	30	12 68	0
7	327	30.323	224.3	27	34	1	30	12 88	0
8	328	29.650	223.3	28	-53	1	30	12 88	0
9	329	28.831	222.7	29	6	2	30	12 68	12
10	330	27.877	221.7	30	3	3	30	12 68	0
11	331	26.581	221.9	31	4	1	30	12 48	0
12	332	25.518	221.4	32	21	1	30	12 48	3
13	333	24.879	219.4	33	17	1	30	12 48	0
14	334	24.515	218.4	34	7	1	30	12 48	12
15	335	23.161	218.7	35	-18	1	30	12 48	12
16	336	22.001	218.8	36	3	1	30	12 48	0
17	337	20.896	218.1	37	2	1	30	12 68	0
18	338	20.151	217.6	38	2	1	30	12 68	0
19	339	19.068	215.9	39	1	1	30	12 68	0
20	340	18.382	215.8	40	4	1	30	12 88	0

FIELD DATA TABLE

Shot number 9 Shot point 26 Team 4
Shot time: 161: 9: 4: 0.012

Loc	Dist(km)	Azim	Unit	Chron	Chan	C1	C2	C3	Tape grade
1	361	2.751	54.2	61	14	3	30	12 68	0
2	362	3.939	49.0	62	2	3	30	12 48	0
3	363	5.005	49.2	63	8	3	30	12 48	0
4	364	5.853	50.5	64	26	1	30	12 48	0
5	365	6.963	50.7	65	-6	3	30	12 48	0
6	366	7.978	51.7	66	16	3	30	12 48	0
7	367	8.938	52.3	67	0	3	30	12 48	0
8	368	113.522	46.4	68	-4	1	30	12 48	0
9	369	10.973	54.4	69	2	1	30	12 48	1
10	370	11.848	56.5	70	42	1	30	12 48	0
11	371	13.236	57.3	71	5	3	30	12 48	0
12	372	14.226	55.3	72	21	3	30	12 48	0
13	373	14.987	53.3	73	-26	1	30	12 48	0
14	374	15.913	51.2	74	3	1	30	12 48	0
15	375	16.936	49.7	75	19	1	30	12 68	0
16	376	17.865	50.4	76	0	3	30	12 68	0
17	377	18.893	51.9	77	10	1	30	12 68	0
18	378	19.850	52.0	78	-3	1	30	12 88	0
19	380	21.852	55.4	79	7	1	30	12 88	0
20	379	20.911	54.1	80	16	1	30	12 88	0

FIELD DATA TABLE

Shot number 9 Shot point 26 Team 5
Shot time: 161: 9: 4: 0.012

Loc	Dist(km)	Azim	Unit	Chron	Chan	C1	C2	C3	Tape	grade
1	381	22.838	81	-11	1	30	12	48	0	0
2	382	23.754	82	-4	1	30	12	48	0	0
3	383	24.879	83	11	3	30	12	48	0	0
4	384	26.075	84	-6	1	30	12	48	0	0
5	385	26.917	85	5	1	30	12	48	0	0
6	386	28.028	86	-2	1	30	12	48	0	0
7	387	29.149	87	1	1	30	12	48	0	0
8	388	30.275	88	12	1	30	12	48	4	4
9	389	31.403	89	-2	1	30	12	48	0	0
10	390	32.481	90	6	1	30	12	48	0	0
11	391	33.613	91	9	1	30	12	48	0	0
12	392	34.909	92	0	1	30	12	68	0	0
13	393	36.228	93	5	1	30	12	68	0	0
14	394	37.622	94	12	1	30	12	88	0	0
15	395	38.635	95	0	1	30	12	68	0	0
16	396	39.329	96	-10	2	30	12	68	0	0
17	397	40.299	97	2	1	30	12	68	0	0
18	398	41.168	98	-19	2	12	12	12	0	0
19	399	42.343	99	11	1	30	12	48	0	0
20	400	43.486	100	8	1	30	12	48	0	0

Shot number 10 Shot point 39 Team 1
Shot time: 161: 9: 6: 0.008

Loc	Dist(km)	Azim	Unit	Chron	Chan	C1	C2	C3	Tape	grade
1	301	47.621	1	12	1	30	12	88	0	0
2	302	48.151	2	10	1	30	12	88	0	0
3	303	48.912	3	6	1	30	12	68	0	0
4	304	50.392	4	-20	1	30	12	48	0	0
5	305	51.190	5	9	1	30	12	48	12	12
6	306	52.212	6	5	1	30	12	48	0	0
7	307	52.743	7	-3	1	30	12	48	1	1
8	308	53.360	8	11	1	30	12	48	0	0
9	309	54.656	9	14	1	30	12	48	0	0
10	310	56.025	10	2	1	30	12	48	0	0
11	311	56.920	11	-36	1	30	12	48	0	0
12	312	57.882	12	4	1	30	12	48	0	0
13	313	58.904	13	5	1	30	12	48	0	0
14	314	60.125	14	-14	1	30	12	48	0	0
15	315	0.006	15	1	1	30	12	88	12	12
16	316	61.958	16	-3	2	30	12	48	0	0
17	317	62.631	17	14	2	30	12	48	0	0
18	318	63.437	18	-12	2	30	12	48	0	0
19	319	64.537	19	19	2	30	12	48	0	0
20	320	65.306	20	-4	1	30	12	48	29	29

FIELD DATA TABLE

Shot number 9 Shot point 26 Team 6
Shot time: 161: 9: 4: 0.012

Loc	Dist(km)	Azim	Unit	Chron	Chan	C1	C2	C3	Tape	grade
1	401	44.407	70.1	101	24	1	30	12	48	0
2	402	45.169	69.3	102	16	1	30	12	48	0
3	403	47.743	65.7	103	4	2	30	12	48	0
4	404	46.772	67.0	104	-3	3	30	12	48	0
5	405	48.542	64.9	105	35	1	30	12	48	0
6	406	49.607	64.2	106	0	1	30	12	48	0
7	407	50.338	63.7	107	39	2	30	12	48	0
8	408	51.454	63.5	108	2	1	30	12	48	0
9	409	52.514	63.2	109	7	2	30	12	48	0
10	410	53.438	62.7	110	25	1	30	12	48	0
11	411	54.155	61.2	111	63	1	30	12	68	0
12	412	55.167	59.8	112	13	1	30	12	88	0
13	413	62.484	54.9	113	-6	1	30	12	48	0
14	414	67.436	57.3	114	0	1	30	12	48	0
15	415	73.329	59.2	115	11	2	30	12	48	0
16	416	79.107	54.0	116	37	2	30	12	48	0
17	417	84.657	51.1	117	10	1	30	12	48	0
18	418	91.193	49.4	118	18	1	30	12	48	0
19	419	97.318	50.0	119	8	1	30	12	48	1
20	420	105.659	49.2	120	3	1	30	12	48	0

FIELD DATA TABLE

Shot number 10 Shot point 39 Team 2
Shot time: 161: 9: 6: 0.008

Loc	Dist(km)	Azim	Unit	Chron	Chan	C1	C2	C3	Tape	grade
1	321	66.086	61.6	21	-2	1	30	12	48	0
2	322	67.239	61.0	22	7	2	30	12	48	0
3	323	68.313	60.5	23	13	1	30	12	48	12
4	324	69.449	60.0	24	0	2	30	12	48	12
5	325	70.264	60.5	25	5	2	30	12	68	0
6	326	70.917	60.4	26	3	2	30	12	68	0
7	327	72.467	61.0	27	34	1	30	12	88	0
8	328	73.270	61.2	28	-53	2	30	12	88	0
9	329	74.154	61.3	29	6	2	30	12	68	12
10	330	75.220	61.4	30	3	2	30	12	68	0
11	331	76.405	61.0	31	4	1	30	12	48	0
12	332	77.481	60.9	32	21	1	30	12	48	0
13	333	78.393	61.3	33	17	1	30	12	48	0
14	334	78.894	61.5	34	7	1	30	12	48	12
15	335	79.811	61.0	35	-18	3	30	12	48	12
16	336	80.864	60.7	36	3	2	30	12	48	0
17	337	81.977	60.6	37	2	2	30	12	68	0
18	338	82.738	60.5	38	2	2	30	12	68	0
19	339	83.959	60.6	39	1	2	30	12	88	0
20	340	84.597	60.4	40	4	2	30	12	88	0

FIELD DATA TABLE

Shot number 10 Shot point 39 Team 3
Shot time: 161: 9: 6: 0.008

Loc	Dist(km)	Azim	Unit	Chron	Chan	C1	C2	C3	Tape	grade
1	341	85.950	41	-8	2	30	12	68	0	0
2	342	86.954	59.0	42	5	2	30	12	48	0
3	343	87.684	58.7	43	2	2	30	12	48	0
4	344	88.592	58.2	44	10	2	30	12	48	0
5	345	89.520	57.7	45	1	2	30	12	48	0
6	346	90.438	57.3	46	3	2	30	12	48	0
7	347	91.603	57.1	47	-4	2	30	12	48	0
8	348	92.802	56.9	48	0	2	30	12	48	0
9	349	93.552	57.0	49	1	2	30	12	48	0
10	350	94.508	57.3	50	-14	2	30	12	48	0
11	351	95.507	57.4	51	10	2	30	12	48	0
12	352	96.605	57.7	52	-5	2	30	12	48	0
13	353	97.479	57.6	53	7	2	30	12	48	0
14	354	98.247	57.3	54	-4	3	30	12	48	0
15	355	98.977	57.0	55	7	2	30	12	68	0
16	356	99.904	56.5	56	13	2	30	12	68	0
17	357	100.490	56.1	57	9	2	30	12	68	0
18	358	101.462	56.1	58	9	2	30	12	88	0
19	359	102.323	56.4	59	-2	2	30	12	88	0
20	360	103.475	56.2	60	-3	2	30	12	88	0

FIELD DATA TABLE

Shot number 10 Shot point 39 Team 5
Shot time: 161: 9: 6: 0.008

Loc	Dist(km)	Azim	Unit	Chron	Chan	C1	C2	C3	Tape	grade
1	381	124.222	56.2	81	-11	2	30	12	48	0
2	382	125.128	56.5	82	-4	2	30	12	48	0
3	383	126.217	56.9	83	11	2	30	12	48	0
4	384	127.362	57.3	84	-6	2	30	12	48	0
5	385	128.177	57.5	85	5	2	30	12	48	0
6	386	129.243	57.7	86	-2	2	30	12	48	0
7	387	130.312	58.0	87	1	2	30	12	48	29
8	388	131.385	58.2	88	12	2	30	12	48	4
9	389	132.448	58.5	89	-2	2	30	12	48	0
10	390	133.452	58.7	90	6	1	30	12	48	0
11	391	134.498	59.0	91	9	2	30	12	48	0
12	392	135.600	59.6	92	0	2	30	12	68	0
13	393	136.950	59.6	93	5	1	30	12	68	0
14	394	138.333	59.6	94	12	1	30	12	88	0
15	395	139.306	59.8	95	0	2	30	12	68	0
16	396	139.914	60.0	96	-10	2	30	12	68	0
17	397	140.824	60.2	97	2	1	30	12	68	0
18	398	141.630	60.4	98	-19	2	12	12	12	0
19	399	142.805	60.4	99	11	1	30	12	48	12
20	400	143.966	60.4	100	8	1	30	12	48	0

FIELD DATA TABLE

Shot number 10 Shot point 39 Team 4
Shot time: 161: 9: 6: 0.008

Loc	Dist(km)	Azim	Unit	Chron	Chan	C1	C2	C3	Tape	grade
1	361	104.202	56.0	61	14	2	30	12	68	0
2	362	105.354	55.8	62	2	2	30	12	48	0
3	363	106.410	55.7	63	8	2	30	12	48	0
4	364	107.263	55.8	64	26	1	30	12	48	0
5	365	108.366	55.7	65	-6	1	30	12	48	0
6	366	109.385	55.7	66	16	2	30	12	48	0
7	367	110.346	55.8	67	0	2	30	12	48	0
8	368	213.984	50.9	68	-4	2	30	12	48	0
9	369	112.390	55.9	69	2	2	30	12	48	1
10	370	113.270	56.1	70	42	2	30	12	48	0
11	371	114.653	56.2	71	5	1	30	12	48	0
12	372	115.635	56.0	72	21	1	30	12	48	0
13	373	116.375	55.7	73	-26	2	30	12	48	0
14	374	117.294	55.4	74	3	2	30	12	48	0
15	375	118.228	55.1	75	19	1	30	12	68	0
16	376	119.171	55.2	76	0	1	30	12	68	0
17	377	120.232	55.4	77	10	2	30	12	68	0
18	378	121.186	55.4	78	-3	2	30	12	88	0
19	380	123.244	55.9	79	7	2	30	12	88	0
20	379	122.283	55.7	80	16	2	30	12	88	0

FIELD DATA TABLE

Shot number 10 Shot point 39 Team 6
Shot time: 161: 9: 6: 0.008

Loc	Dist(km)	Azim	Unit	Chron	Chan	C1	C2	C3	Tape	grade
1	401	144.913	60.4	101	24	2	30	12	48	0
2	402	145.763	60.1	102	16	2	30	12	48	12
3	403	148.673	59.2	103	4	2	30	12	48	0
4	404	147.589	59.5	104	-3	1	30	12	48	0
5	405	149.529	58.9	105	35	2	30	12	48	0
6	406	150.643	58.7	106	0	2	30	12	48	0
7	407	151.401	58.6	107	39	2	30	12	48	0
8	408	152.526	58.6	108	2	2	30	12	48	0
9	409	153.602	58.5	109	7	2	30	12	48	0
10	410	154.549	58.4	110	25	1	30	12	48	0
11	411	155.342	57.8	111	63	1	30	12	68	0
12	412	156.400	57.4	112	13	2	30	12	88	0
13	413	163.702	55.6	113	-6	1	30	12	48	0
14	414	168.665	56.6	114	0	2	30	12	48	0
15	415	174.513	57.4	115	11	2	30	12	48	0
16	416	180.225	55.1	116	37	2	30	12	48	0
17	417	185.849	53.8	117	10	2	30	12	48	0
18	418	192.192	52.9	118	18	2	30	12	48	0
19	419	198.362	53.1	119	8	2	30	12	48	1
20	420	206.577	52.5	120	3	2	30	12	48	0

FIELD DATA TABLE

Shot number 11 Shot point 24 Team 1
Shot time: 161:11: 0: 0.010

Loc	Dist(km)	Azim	Unit	Chron	Chan	C1	C2	C3	Tape grade
1	301	0.009	133.2	1	13	3	30	12 88	0
2	302	0.734	108.5	2	11	3	30	12 88	0
3	303	2.150	118.8	3	7	3	30	12 68	0
4	304	3.469	102.9	4	-23	3	30	12 48	0
5	305	3.840	87.1	5	10	3	30	12 48	0
6	306	4.696	77.3	6	6	3	30	12 48	0
7	307	5.196	74.8	7	-3	3	30	12 48	1
8	308	5.763	70.0	8	12	3	30	12 48	0
9	309	7.053	68.9	9	16	3	30	12 48	0
10	310	8.450	71.1	10	2	3	30	12 48	0
11	311	9.365	72.1	11	-41	1	30	12 48	0
12	312	10.324	71.7	12	4	3	30	12 48	0
13	313	11.358	72.1	13	6	1	30	12 48	0
14	314	12.539	69.5	14	-16	2	30	12 48	0
15	315	14.358	244.4	15	1	1	30	12 88	0
16	316	14.358	61.5	16	-4	3	30	12 48	0
17	317	15.048	60.3	17	16	3	30	12 48	0
18	318	15.874	59.3	18	-14	3	30	12 48	0
19	319	17.055	56.4	19	21	1	30	12 48	0
20	320	17.825	56.5	20	-4	1	30	12 48	12

FIELD DATA TABLE

Shot number 11 Shot point 24 Team 3
Shot time: 161:11: 0: 0.010

Loc	Dist(km)	Azim	Unit	Chron	Chan	C1	C2	C3	Tape grade
1	341	39.018	54.1	41	-9	1	30	12 68	0
2	342	40.141	52.7	42	6	1	30	12 48	0
3	343	40.930	52.1	43	2	1	30	12 48	0
4	344	41.923	51.2	44	11	1	30	12 48	0
5	345	42.947	50.4	45	1	1	30	12 48	0
6	346	43.954	49.6	46	3	1	30	12 48	0
7	347	45.161	49.4	47	-5	1	30	12 48	0
8	348	46.389	49.3	48	0	1	30	12 48	0
9	349	47.110	49.6	49	2	1	30	12 48	0
10	350	48.012	50.2	50	-16	1	30	12 48	0
11	351	48.979	50.7	51	11	1	30	12 48	0
12	352	50.016	51.4	52	-5	1	30	12 48	0
13	353	50.909	51.3	53	8	1	30	12 48	0
14	354	51.726	50.9	54	-4	1	30	12 48	0
15	355	52.530	50.3	55	8	1	30	12 68	0
16	356	53.543	49.6	56	15	1	30	12 68	0
17	357	54.219	49.0	57	10	1	30	12 68	0
18	358	55.199	49.0	58	10	1	30	12 88	0
19	359	55.980	49.7	59	-2	1	30	12 88	0
20	360	57.185	49.4	60	-4	2	30	12 88	0

FIELD DATA TABLE

Shot number 11 Shot point 24 Team 2
Shot time: 161:11: 0: 0.010

Loc	Dist(km)	Azim	Unit	Chron	Chan	C1	C2	C3	Tape grade
1	321	18.680	54.7	21	-2	1	30	12 48	0
2	322	19.918	53.1	22	8	1	30	12 48	0
3	323	21.069	51.9	23	14	0	30	12 48	12
4	324	22.299	50.6	24	0	1	30	12 48	12
5	325	23.014	52.4	25	6	1	30	12 68	0
6	326	23.673	52.4	26	3	1	30	12 68	0
7	327	25.116	54.6	27	38	1	30	12 88	0
8	328	25.881	55.4	28	-60	1	30	12 88	0
9	329	26.755	55.7	29	7	1	30	12 68	12
10	330	27.801	56.3	30	4	1	30	12 68	0
11	331	29.033	55.5	31	5	1	30	12 48	0
12	332	30.119	55.4	32	24	1	30	12 48	0
13	333	30.972	56.6	33	19	1	30	12 48	0
14	334	31.450	57.2	34	8	0	30	12 48	12
15	335	32.699	56.2	35	-20	0	30	12 48	12
16	336	33.796	55.6	36	3	1	30	12 48	0
17	337	34.926	55.4	37	2	1	30	12 68	0
18	338	35.697	55.4	38	2	1	30	12 68	0
19	339	36.910	55.7	39	1	1	30	12 88	0
20	340	37.570	55.4	40	5	1	30	12 88	0

FIELD DATA TABLE

Shot number 11 Shot point 24 Team 4
Shot time: 161:11: 0: 0.010

Loc	Dist(km)	Azim	Unit	Chron	Chan	C1	C2	C3	Tape grade
1	361	57.946	49.2	61	15	2	30	12 68	0
2	362	59.143	48.9	62	2	2	30	12 48	0
3	363	60.210	49.0	63	8	1	30	12 48	0
4	364	61.057	49.1	64	28	1	30	12 48	0
5	365	62.166	49.1	65	-6	1	30	12 48	0
6	366	63.177	49.3	66	17	2	30	12 48	0
7	367	64.133	49.4	67	0	0	30	12 48	17
8	368	168.476	47.2	68	-4	2	30	12 48	0
9	369	65.144	49.8	69	2	1	30	12 48	1
10	370	66.979	50.3	70	44	1	30	12 48	0
11	371	68.340	50.6	71	5	1	30	12 48	0
12	372	69.371	50.2	72	22	1	30	12 48	0
13	373	70.165	49.9	73	-28	1	30	12 48	0
14	374	71.112	49.4	74	3	1	30	12 48	0
15	375	72.141	49.1	75	20	1	30	12 68	0
16	376	73.068	49.3	76	0	1	30	12 68	0
17	377	74.085	49.7	77	10	1	30	12 68	0
18	378	75.041	49.8	78	-3	2	30	12 68	0
19	380	76.983	50.8	79	8	2	30	12 88	0
20	379	76.066	50.4	80	17	2	30	12 88	0

FIELD DATA TABLE

Shot number 11 Shot point 24 Team 5
Shot time: 161:11:0:0.010

Loc	Dist(km)	Azim	Unit	Chron	Chan	C1	C2	C3	Tape
1	381	77.912	81	-12	2	30	12	48	0
2	382	78.755	82	-4	2	30	12	48	0
3	383	79.769	83	13	1	30	12	48	0
4	384	80.582	84	-7	1	30	12	48	4
5	385	81.367	85	6	2	30	12	48	0
6	386	82.391	86	-3	2	30	12	48	0
7	387	83.419	87	2	1	30	12	48	0
8	388	84.456	88	14	1	30	12	48	4
9	389	85.478	89	-2	1	30	12	48	0
10	390	86.442	90	7	1	30	12	48	0
11	391	87.448	91	10	1	30	12	48	0
12	392	88.479	92	0	1	30	12	68	0
13	393	89.833	93	5	1	30	12	68	0
14	394	91.206	94	14	1	30	12	68	0
15	395	92.163	95	0	1	30	12	68	0
16	396	92.745	96	-11	1	30	12	68	0
17	397	93.635	97	2	1	30	12	68	0
18	398	94.423	98	-22	2	12	12	12	0
19	399	95.593	99	13	1	30	12	48	0
20	400	96.756	100	9	1	30	12	48	0

FIELD DATA TABLE

Shot number 12 Shot point 40 Team 1
Shot time: 170:6:30:0.012

Loc	Dist(km)	Azim	Unit	Chron	Chan	C1	C2	C3	Tape	
1	501	69.508	141.0	1	39	30	12	88	1	
2	502	70.645	141.8	2	63	30	12	88	12	
3	503	71.498	142.6	3	22	2	30	12	68	0
4	504	72.174	143.3	4	-76	1	30	12	48	0
5	505	72.005	144.4	5	30	2	30	12	48	0
6	506	71.890	145.0	6	9	2	30	12	48	0
7	507	71.415	146.0	7	27	2	30	12	48	0
8	508	71.471	146.7	8	67	1	30	12	48	0
9	509	71.253	147.5	9	95	1	30	12	48	0
10	510	74.525	148.3	10	55	2	30	12	48	0
11	511	73.871	148.9	11	11	2	30	12	48	0
12	512	73.871	149.9	12	15	2	30	12	48	0
13	513	73.524	150.4	13	64	1	30	12	48	0
14	514	73.371	151.2	14	-48	1	30	12	48	0
15	515	73.317	152.0	15	9	2	30	12	48	0
16	516	73.302	153.1	16	-10	2	30	12	48	0
17	517	74.082	153.6	17	44	2	30	12	48	0
18	518	74.296	154.4	18	-45	2	30	12	48	0
19	621	146.267	203.8	19	76	2	30	12	88	0
20	520	75.232	155.7	20	28	2	30	12	48	0

FIELD DATA TABLE

Shot number 11 Shot point 24 Team 6
Shot time: 161:11:0:0.010

Loc	Dist(km)	Azim	Unit	Chron	Chan	C1	C2	C3	Tape	
1	401	97.706	58.4	101	25	1	30	12	48	0
2	402	98.577	58.1	102	17	30	12	48	12	0
3	403	101.600	56.7	103	4	30	12	48	12	0
4	404	100.470	57.3	104	-3	1	30	12	48	0
5	405	102.484	56.4	105	38	2	30	12	48	0
6	406	103.623	56.2	106	0	1	30	12	48	0
7	407	104.397	56.0	107	41	2	30	12	48	0
8	408	105.529	56.0	108	2	1	30	12	48	0
9	409	106.615	55.9	109	8	1	30	12	48	0
10	410	107.579	55.7	110	27	30	12	48	29	0
11	411	108.446	55.0	111	67	1	30	12	68	0
12	412	109.575	54.4	112	13	1	30	12	88	0
13	413	117.179	52.1	113	-7	1	30	12	48	0
14	414	121.970	53.6	114	0	1	30	12	48	0
15	415	127.683	54.8	115	11	1	30	12	48	0
16	416	133.781	51.9	116	40	2	30	12	48	0
17	417	139.676	50.3	117	10	2	30	12	48	0
18	418	146.219	49.2	118	19	1	30	12	48	0
19	419	152.345	49.6	119	8	30	12	48	1	0
20	420	160.682	49.1	120	3	2	30	12	48	0

FIELD DATA TABLE

Shot number 12 Shot point 40 Team 2
Shot time: 170:6:30:0.012

Loc	Dist(km)	Azim	Unit	Chron	Chan	C1	C2	C3	Tape	
1	521	74.880	156.5	21	-38	2	30	12	48	0
2	522	74.810	157.5	22	14	2	30	12	48	0
3	523	74.739	158.3	23	26	2	30	12	48	0
4	524	74.505	159.1	24	-7	2	30	12	48	0
5	525	74.763	159.5	25	58	1	30	12	48	0
6	526	75.493	160.2	26	11	2	30	12	48	0
7	527	76.145	160.9	27	7	1	30	12	48	0
8	528	76.082	161.8	28	-42	2	30	12	48	0
9	529	76.605	162.5	29	16	2	30	12	68	0
10	530	76.779	163.2	30	11	2	30	12	68	0
11	531	77.376	163.8	31	4	1	30	12	88	0
12	532	77.718	164.6	32	62	2	30	12	88	0
13	533	78.101	165.2	33	100	1	30	12	88	0
14	534	78.179	165.9	34	19	1	30	12	88	0
15	535	77.882	166.9	35	-57	1	30	12	68	0
16	536	77.880	167.7	36	8	1	30	12	68	0
17	537	77.732	168.6	37	4	2	30	12	48	0
18	538	77.887	169.0	38	1	2	30	12	48	0
19	539	77.778	170.2	39	-7	2	30	12	48	0
20	540	77.617	170.9	40	--	--	30	12	48	12

FIELD DATA TABLE

Shot number 12 Shot point 40 Team 3
Shot time: 170: 6:30: 0.012

Loc	Dist(km)	Azim	Unit	Chron	Chan	C1	C2	C3	Tape
1	541	77.901	171.8	41	-35	30	12	48	1
2	542	78.136	172.4	42	15	2	30	12	48
3	543	78.706	173.0	43	73	2	30	12	48
4	544	79.042	173.7	44	106	2	30	12	48
5	545	79.654	174.3	45	0	1	30	12	48
6	546	79.354	175.2	46	14	1	30	12	48
7	547	79.552	176.0	47	2	2	30	12	48
8	548	79.856	176.8	48	63	1	30	12	48
9	549	79.923	177.4	49	24	1	30	12	48
10	550	80.865	177.7	50	-47	1	30	12	48
11	622	147.015	204.0	51	59	2	30	12	88
12	552	81.582	179.3	52	45	1	30	12	48
13	553	82.355	179.8	53	11	1	30	12	48
14	554	82.147	180.3	54	-11	1	30	12	48
15	555	82.652	181.3	55	60	2	30	12	48
16	556	83.311	181.8	56	39	2	30	12	48
17	557	83.841	182.3	57	80	2	30	12	48
18	558	84.865	182.9	58	19	2	30	12	48
19	559	85.696	183.2	59	-4	2	30	12	48
20	560	87.015	183.1	60	-12	2	30	12	48

FIELD DATA TABLE

Shot number 12 Shot point 40 Team 5
Shot time: 170: 6:30: 0.012

Loc	Dist(km)	Azim	Unit	Chron	Chan	C1	C2	C3	Tape
1	581	108.094	197.5	81	-35	2	30	12	48
2	582	108.828	197.9	82	-14	2	30	12	48
3	583	109.834	198.0	83	-17	2	30	12	48
4	584	110.463	198.4	84	-27	2	30	12	48
5	585	111.303	199.1	85	125	2	30	12	48
6	623	147.583	204.2	86	-10	2	30	12	88
7	587	113.158	199.2	87	3	2	30	12	48
8	588	114.398	199.2	88	34	2	30	12	48
9	589	115.403	199.5	89	11	2	30	12	48
10	590	116.338	199.7	90	12	2	30	12	48
11	591	116.966	199.9	91	24	2	30	12	48
12	592	117.956	200.1	92	-6	2	30	12	48
13	593	118.238	200.5	93	19	2	30	12	48
14	594	119.453	200.5	94	40	2	30	12	48
15	595	121.454	200.1	95	-3	2	30	12	48
16	596	122.534	200.1	96	183	2	30	12	48
17	597	123.441	200.2	97	3	1	30	12	48
18	598	124.215	200.6	98	42	2	30	12	48
19	599	124.894	200.8	99	35	2	30	12	48
20	600	125.795	201.0	100	24	2	30	12	48

FIELD DATA TABLE

Shot number 12 Shot point 40 Team 4
Shot time: 170: 6:30: 0.012

Loc	Dist(km)	Azim	Unit	Chron	Chan	C1	C2	C3	Tape
1	561	87.426	183.8	61	17	2	30	12	48
2	562	89.367	184.2	62	1	1	30	12	48
3	563	89.954	184.0	63	39	1	30	12	48
4	564	96.642	190.5	64	35	2	30	12	88
5	565	96.906	190.9	65	-10	2	30	12	88
6	566	97.980	191.4	66	11	2	30	12	88
7	567	98.634	191.8	67	-14	2	30	12	68
8	568	98.782	192.2	68	-10	2	30	12	68
9	569	99.585	193.1	69	11	30	12	48	1
10	570	100.253	193.5	70	63	2	30	12	48
11	571	100.675	193.6	71	31	2	30	12	48
12	572	101.530	194.3	72	30	2	30	12	48
13	573	102.217	194.6	73	-31	2	30	12	48
14	574	102.875	194.9	74	22	2	30	12	48
15	575	103.625	195.3	75	23	2	30	12	48
16	576	103.795	195.7	76	-9	1	30	12	48
17	577	104.616	196.3	77	-67	2	30	12	48
18	578	105.260	196.6	78	-13	30	12	48	17
19	579	106.576	197.1	79	186	2	30	12	48
20	580	107.212	197.2	80	18	30	12	48	1

FIELD DATA TABLE

Shot number 12 Shot point 40 Team 6
Shot time: 170: 6:30: 0.012

Loc	Dist(km)	Azim	Unit	Chron	Chan	C1	C2	C3	Tape
1	601	127.297	200.6	101	33	1	30	12	48
2	602	128.475	201.1	102	8	2	30	12	48
3	603	129.209	201.0	103	1	2	30	12	48
4	604	129.931	201.4	104	-6	2	30	12	48
5	605	130.331	201.8	105	51	2	30	12	48
6	606	131.146	202.2	106	-7	2	30	12	48
7	607	131.932	202.3	107	69	1	30	12	48
8	608	133.331	202.4	108	-2	2	30	12	48
9	609	133.890	202.7	109	8	2	30	12	48
10	610	134.898	202.9	110	38	2	30	12	48
11	612	136.787	203.1	111	--	--	30	12	88
12	613	137.780	203.1	112	-12	2	30	12	48
13	614	138.526	203.5	113	--	2	30	12	48
14	615	139.294	203.7	114	-2	30	12	48	7
15	616	141.623	203.4	115	-138	30	12	48	1
16	617	142.193	203.5	116	--	30	12	48	1
17	618	142.930	203.3	117	79	30	12	48	1
18	619	144.359	203.5	118	76	2	30	12	48
19	620	145.336	203.5	119	12	2	30	12	48
20	620	145.336	203.6	120	3	2	30	12	48

FIELD DATA TABLE

Shot number 13 Shot point 33 Team 1
Shot time: 170: 6:32: 0.008

Loc	Dist(km)	Azim	Unit	Chron	Chan	C1	C2	C3	Tape grade
1	32.280	48.0	1	39	1	30	12	88	1
2	31.163	50.0	2	63	3	30	12	88	0
3	30.231	51.5	3	22	1	30	12	68	0
4	29.250	52.8	4	-76	1	30	12	48	0
5	27.904	52.4	5	30	1	30	12	48	0
6	27.161	52.1	6	9	1	30	12	48	0
7	25.915	50.8	7	27	1	30	12	48	0
8	25.028	50.8	8	67	1	30	12	48	0
9	24.095	50.0	9	95	1	30	12	48	0
10	22.877	57.8	10	55	1	30	12	48	0
11	22.085	55.9	11	11	1	30	12	48	0
12	20.715	55.8	12	15	1	30	12	48	0
13	20.125	54.7	13	64	1	30	12	48	0
14	19.123	53.9	14	-48	1	30	12	48	0
15	18.102	53.2	15	9	1	30	12	48	0
16	16.659	52.3	16	-10	1	30	12	48	0
17	15.989	54.7	17	44	1	30	12	48	0
18	14.815	54.8	18	-45	1	30	12	48	0
19	98.982	233.8	19	76	2	30	12	88	0
20	12.991	57.5	20	28	1	30	12	48	0

FIELD DATA TABLE

Shot number 13 Shot point 33 Team 3
Shot time: 170: 6:32: 0.008

Loc	Dist(km)	Azim	Unit	Chron	Chan	C1	C2	C3	Tape grade
1	9.195	260.4	41	-35	30	12	48	1	
2	10.089	259.2	42	15	3	30	12	48	0
3	10.924	256.5	43	73	3	30	12	48	0
4	11.960	255.5	44	106	3	30	12	48	0
5	12.903	253.4	45	0	1	30	12	48	0
6	14.080	255.6	46	15	1	30	12	48	0
7	15.249	255.6	47	2	1	30	12	48	0
8	16.354	254.7	48	63	1	30	12	48	0
9	17.284	255.1	49	24	1	30	12	48	0
10	17.872	252.4	50	-47	1	30	12	48	0
11	19.951	233.9	51	59	1	30	12	88	12
12	20.230	252.2	52	45	1	30	12	48	0
13	21.226	250.9	53	11	1	30	12	48	0
14	21.789	252.0	54	-11	1	30	12	48	0
15	23.443	252.0	55	60	2	30	12	48	0
16	24.298	251.1	56	39	30	12	48	29	
17	25.109	250.5	57	81	1	30	12	48	0
18	26.411	249.2	58	19	2	30	12	48	0
19	27.114	248.0	59	-4	1	30	12	48	0
20	27.664	245.4	60	-12	1	30	12	48	0

FIELD DATA TABLE

Shot number 13 Shot point 33 Team 2
Shot time: 170: 6:32: 0.008

Loc	Dist(km)	Azim	Unit	Chron	Chan	C1	C2	C3	Tape grade
1	11.996	55.0	21	-38	1	30	12	48	0
2	10.806	53.3	22	14	1	30	12	48	0
3	9.783	51.2	23	26	3	30	12	48	0
4	8.900	47.8	24	-7	3	30	12	48	0
5	8.316	48.1	25	58	3	30	12	48	0
6	7.150	50.6	26	11	3	30	12	48	0
7	6.056	53.4	27	7	3	30	12	48	12
8	4.931	48.2	28	-42	3	30	12	68	0
9	3.899	49.9	29	16	3	30	12	68	0
10	2.939	45.4	30	11	3	30	12	68	0
11	1.944	49.6	31	4	3	30	12	88	0
12	0.899	42.6	32	62	3	30	12	88	0
13	0.195	285.5	33	100	3	30	12	88	0
14	1.055	256.8	34	19	3	30	12	88	0
15	3.520	263.4	35	-57	3	30	12	68	0
16	3.622	261.6	36	8	3	30	12	68	0
17	4.816	262.6	37	4	3	30	12	48	0
18	5.390	260.5	38	1	3	30	12	48	0
19	6.982	261.2	39	-7	3	30	12	48	0
20	7.929	262.3	40	--	3	30	12	48	1

FIELD DATA TABLE

Shot number 13 Shot point 33 Team 4
Shot time: 170: 6:32: 0.008

Loc	Dist(km)	Azim	Unit	Chron	Chan	C1	C2	C3	Tape grade
1	28.804	245.7	61	18	2	30	12	48	0
2	30.315	243.0	62	1	2	30	12	48	0
3	30.327	241.8	63	39	1	30	12	48	0
4	42.940	242.7	64	35	2	30	12	88	12
5	43.613	243.0	65	-10	2	30	12	88	0
6	44.988	242.6	66	11	2	30	12	88	0
7	45.924	242.5	67	-14	3	30	12	68	0
8	46.600	242.9	68	-10	2	30	12	68	0
9	48.319	243.4	69	11	2	30	12	48	1
10	49.283	243.3	70	63	2	30	12	48	0
11	49.795	243.2	71	31	2	30	12	48	0
12	51.237	243.3	72	30	2	30	12	48	0
13	52.062	243.1	73	-31	2	30	12	48	0
14	52.998	243.0	74	22	1	30	12	48	0
15	54.057	242.9	75	23	30	12	48	0	
16	54.666	243.3	76	-9	2	30	12	48	0
17	56.016	243.4	77	-67	2	30	12	48	0
18	56.903	243.4	78	-13	2	30	12	48	1
19	58.435	243.0	79	186	1	30	12	48	0/ 9
20	59.105	242.8	80	18	30	12	48	1	

FIELD DATA TABLE

Shot number 13 Shot point 33 Team 5
Shot time: 170: 6:32: 0.008

Loc	Dist(km)	Azim	Unit	Chron	Chan	C1	C2	C3	Tape grade
1	581	60.113	242.5	81	-35	30	12	48	12
2	582	61.214	242.6	82	-14	2	30	12 48	0
3	583	62.045	242.0	83	-17	2	30	12 48	0
4	584	63.041	242.1	84	-27	2	30	12 48	12
5	585	64.594	242.5	85	126	2	30	12 48	0
6	623	100.673	234.0	86	-10	2	30	12 88	0
7	587	66.084	241.5	87	3	2	30	12 48	0
8	588	67.041	240.8	88	34	2	30	12 48	0
9	589	68.150	240.6	89	11	2	30	12 48	0
10	590	69.126	240.3	90	12	2	30	12 48	0
11	591	69.881	240.2	91	24	2	30	12 48	0
12	592	71.021	240.1	92	-6	2	30	12 48	12
13	593	71.673	240.3	93	19	2	30	12 48	0
14	594	72.594	239.7	94	40	2	30	12 48	0
15	595	73.638	238.2	95	-5	2	30	12 48	0
16	596	74.531	237.7	96	183	2	30	12 48	0
17	597	75.426	237.5	97	3	2	30	12 48	0
18	598	76.559	237.6	98	42	2	30	12 48	0
19	599	77.378	237.6	99	35	2	30	12 48	0
20	600	78.383	237.5	100	24	2	30	12 48	0

FIELD DATA TABLE

Shot number 14 Shot point 32 Team 1
Shot time: 170: 6:34: 0.008

Loc	Dist(km)	Azim	Unit	Chron	Chan	C1	C2	C3	Tape grade
1	501	74.932	56.6	1	39	30	12	88	1
2	502	74.036	57.6	2	63	2	30	12 88	0
3	503	73.219	58.3	3	22	2	30	12 68	0
4	504	72.323	58.9	4	-76	2	30	12 48	0
5	505	70.963	58.9	5	30	2	30	12 48	0
6	506	70.207	58.8	6	10	2	30	12 48	0
7	507	68.898	58.5	7	27	2	30	12 48	0
8	508	68.014	58.6	8	67	2	30	12 48	12
9	509	67.043	58.4	9	95	2	30	12 48	12
10	510	66.181	61.2	10	55	2	30	12 48	0
11	511	65.335	60.6	11	11	2	30	12 48	0
12	512	63.968	60.7	12	15	2	30	12 48	0/ 9
13	513	63.342	60.4	13	64	2	30	12 48	12
14	514	62.316	60.2	14	-48	2	30	12 48	0
15	515	61.278	60.2	15	9	2	30	12 48	0
16	516	59.812	60.1	16	-10	2	30	12 48	0
17	517	59.231	60.8	17	44	2	30	12 48	0
18	518	58.068	61.0	18	-45	2	30	12 48	0
19	621	56.841	226.7	19	76	2	30	12 88	0
20	520	56.316	61.8	20	28	2	30	12 48	0

FIELD DATA TABLE

Shot number 13 Shot point 33 Team 6
Shot time: 170: 6:32: 0.008

Loc	Dist(km)	Azim	Unit	Chron	Chan	C1	C2	C3	Tape grade
1	601	79.128	236.4	101	33	1	30	12 48	0
2	602	80.396	236.4	102	8	2	30	12 48	6
3	603	80.975	236.1	103	1	2	30	12 48	12
4	604	82.095	236.3	104	-6	2	30	12 48	0
5	605	82.840	236.6	105	51	2	30	12 48	0
6	606	84.068	236.8	106	-7	2	30	12 48	0
7	607	84.901	236.7	107	69	1	30	12 48	0
8	608	86.106	236.2	108	-2	1	30	12 48	0
9	609	87.044	236.5	109	8	1	30	12 48	0
10	610	88.082	236.3	110	38	2	30	12 48	0
11				111	--		30	12 88	20
12	612	89.977	235.9	112	-12	2	30	12 48	0
13	613	90.891	235.7	113	--	2	30	12 48	0
14	614	91.986	235.9	114	-2		30	12 48	7
15	615	92.954	235.9	115	-138		30	12 48	1
16	616	94.519	234.8	116	--		30	12 48	1
17	617	95.103	234.7	117	79		30	12 48	1
18	618	95.560	234.3	118	76	2	30	12 48	0
19	619	97.019	234.1	119	12	2	30	12 48	0
20	620	97.955	233.9	120	3	12	30	12 48	12

FIELD DATA TABLE

Shot number 14 Shot point 32 Team 2
Shot time: 170: 6:34: 0.008

Loc	Dist(km)	Azim	Unit	Chron	Chan	C1	C2	C3	Tape grade
1	521	55.274	61.3	21	-38	2	30	12 48	0
2	522	54.049	61.1	22	14	2	30	12 48	0
3	523	52.981	60.9	23	26	2	30	12 48	0
4	524	52.006	60.5	24	-7	2	30	12 48	0
5	525	51.447	60.7	25	58	2	30	12 48	0
6	526	50.376	61.3	26	11	2	30	12 48	0
7	527	49.354	61.9	27	7	2	30	12 48	12
8	528	48.156	61.6	28	-42	2	30	12 48	0
9	529	47.179	62.0	29	16	2	30	12 68	0
10	530	46.184	62.0	30	11	2	30	12 68	0
11	531	45.269	62.5	31	4	2	30	12 88	0
12	532	44.221	62.7	32	62	2	30	12 88	0
13	533	43.235	62.9	33	101	2	30	12 88	0
14	534	42.353	62.7	34	19	2	30	12 88	0
15	535	41.021	61.8	35	-57	2	30	12 68	0
16	536	39.957	61.4	36	8	2	30	12 68	0
17	537	38.864	60.7	37	4	2	30	12 48	12
18	538	38.263	60.6	38	1	2	30	12 48	0
19	539	36.798	59.7	39	-7	2	30	12 48	0
20	540	35.975	58.9	40	--		30	12 48	1

FIELD DATA TABLE

Shot number 14 Shot point 32 Team 3
Shot time: 170: 6:34: 0.008

Loc	Dist(km)	Azim	Unit	Chron	Chan	C1	C2	C3	Tape grade	
1	541	34.698	58.5	41	-35	30	12	48	1	
2	542	33.792	58.3	42	15	30	12	48	0	
3	543	32.841	58.6	43	73	2	30	12	48	0
4	544	31.791	58.4	44	106	2	30	12	48	0
5	545	30.759	58.7	45	0	2	30	12	48	0
6	546	29.776	57.2	46	15	1	30	12	48	0
7	547	28.669	56.4	47	2	2	30	12	48	0
8	548	27.538	56.2	48	63	2	30	12	48	0
9	549	26.702	55.3	49	24	2	30	12	48	0
10	550	25.893	56.6	50	-47	2	30	12	48	0
11	552	23.612	55.2	52	45	2	30	12	48	12
12	553	22.521	55.7	53	11	1	30	12	48	0
13	554	22.094	54.3	54	-11	1	30	12	48	0
14	555	20.532	52.8	55	60	1	30	12	48	0
15	556	19.598	53.1	56	39	3	30	12	48	29
16	557	18.749	53.1	57	81	1	30	12	48	0
17	558	17.341	53.6	58	19	1	30	12	48	0
18	559	16.515	55.0	59	-4	1	30	12	48	0
19	560	15.775	58.9	60	-12	1	30	12	48	0

Shot number 14 Shot point 32 Team 5
Shot time: 170: 6:34: 0.008

Loc	Dist(km)	Azim	Unit	Chron	Chan	C1	C2	C3	Tape grade	
1	581	16.737	241.1	81	-35	2	30	12	48	0
2	582	17.837	241.3	82	-14	2	30	12	48	0
3	583	18.684	239.6	83	-17	1	30	12	48	0
4	584	19.675	240.0	84	-27	1	30	12	48	12
5	585	21.218	241.3	85	126	1	30	12	48	0
6	623	58.491	227.2	86	-10	2	30	12	88	0
7	587	22.743	238.5	87	3	2	30	12	48	0
8	588	23.744	236.6	88	34	2	30	12	48	0
9	589	24.869	236.2	89	11	2	30	12	48	0
10	590	25.864	235.7	90	12	2	30	12	48	0
11	591	26.623	235.6	91	24	2	30	12	48	0
12	592	27.774	235.4	92	-6	2	30	12	48	12
13	593	28.400	236.2	93	19	2	30	12	48	0
14	594	29.378	234.7	94	40	2	30	12	48	0
15	595	30.605	231.3	95	-5	2	30	12	48	0
16	596	31.565	230.4	96	183	2	30	12	48	0
17	597	32.493	230.0	97	3	2	30	12	48	0
18	598	33.592	230.6	98	43	2	30	12	48	0
19	599	34.410	230.7	99	35	2	30	12	48	0
20	600	35.426	230.6	100	24	2	30	12	48	0

FIELD DATA TABLE

Shot number 14 Shot point 32 Team 4
Shot time: 170: 6:34: 0.008

Loc	Dist(km)	Azim	Unit	Chron	Chan	C1	C2	C3	Tape grade	
1	561	14.660	57.8	61	18	1	30	12	48	0
2	562	13.064	63.1	62	1	1	30	12	48	0
3	563	13.082	66.1	63	39	1	30	12	48	0
4	564	0.502	91.6	64	35	3	30	12	88	0
5	565	0.240	229.4	65	-10	3	30	12	88	0
6	566	1.644	230.7	66	11	1	30	12	88	0
7	567	2.580	233.0	67	-14	3	30	12	68	0
8	568	3.222	241.4	68	-10	3	30	12	68	0
9	569	4.948	246.3	69	11	3	30	12	48	1
10	570	5.908	245.1	70	63	3	30	12	48	0
11	571	6.416	243.9	71	31	3	30	12	48	0
12	572	7.861	244.5	72	30	1	30	12	48	0
13	573	8.683	243.1	73	-31	1	30	12	48	0
14	574	9.619	242.8	74	22	1	30	12	48	0
15	575	10.678	242.5	75	23	2	30	12	48	0
16	576	11.289	244.1	76	-9	1	30	12	48	0
17	577	12.642	244.6	77	-67	1	30	12	48	0
18	578	13.527	244.3	78	-13	1	30	12	48	1
19	579	15.055	242.7	79	186	1	30	12	48	0
20	580	15.726	241.9	80	18	1	30	12	48	1

Shot number 14 Shot point 32 Team 6
Shot time: 170: 6:34: 0.008

Loc	Dist(km)	Azim	Unit	Chron	Chan	C1	C2	C3	Tape grade	
1	601	36.357	228.3	101	33	1	30	12	48	0
2	602	37.859	228.8	102	8	2	30	12	48	0
3	603	38.493	228.2	103	1	2	30	12	48	0
4	604	39.564	228.9	104	-6	2	30	12	48	0
5	605	40.261	229.6	105	51	2	30	12	48	0
6	606	41.447	230.2	106	-7	2	30	12	48	0
7	607	42.296	230.1	107	69	1	30	12	48	0
8	608	43.576	229.4	108	-2	2	30	12	48	0
9	609	44.468	230.0	109	8	2	30	12	48	0
10	610	45.530	229.8	110	38	2	30	12	48	0
11	612	47.479	229.4	111	--	--	30	12	88	20
12	613	48.435	229.0	112	-12	2	30	12	48	0
13	614	49.491	229.5	113	--	2	30	12	48	0
14	615	50.447	229.7	114	-2	2	30	12	48	7
15	616	52.213	227.8	115	-138	2	30	12	48	1
16	617	52.810	227.7	116	--	--	30	12	48	1
17	618	53.343	227.1	117	79	2	30	12	48	1
18	619	54.837	226.9	118	76	2	30	12	48	0
19	620	55.808	226.7	119	12	2	30	12	48	0
20	620	55.808	226.7	120	3	2	30	12	48	0

FIELD DATA TABLE

Shot number 15 Shot point 19 Team 1
Shot time: 170:10:30: 0.010

Loc	Dist(km)	Azim	Unit	Chron	Chan	C1	C2	C3	Tape grade
1	501	49.578	215.6	1	42	30	12	88	1
2	502	50.929	214.7	2	68	2	30	12	88
3	503	52.060	214.2	3	24	1	30	12	68
4	504	53.200	213.8	4	-82	1	30	12	48
5	505	54.407	214.5	5	32	1	30	12	48
6	506	55.068	214.9	6	10	1	30	12	48
7	507	56.101	215.8	7	30	1	30	12	48
8	508	56.948	216.0	8	72	2	30	12	48
9	509	57.767	216.6	9	103	2	30	12	48
10	510	59.957	214.0	10	60	2	30	12	48
11	511	60.403	215.0	11	12	2	30	12	48
12	512	61.668	215.4	12	17	2	30	12	48
13	513	62.086	216.0	13	69	2	30	12	48
14	514	62.951	216.5	14	-52	2	30	12	48
15	515	63.866	216.9	15	10	2	30	12	48
16	516	65.179	217.5	16	-11	1	30	12	48
17	517	66.015	217.1	17	48	1	30	12	48
18	518	67.138	217.4	18	-49	2	30	12	48
19	519	67.720	227.8	19	82	2	30	12	88
20	520	69.075	217.4	20	31	2	30	12	48

FIELD DATA TABLE

Shot number 15 Shot point 19 Team 3
Shot time: 170:10:30: 0.010

Loc	Dist(km)	Azim	Unit	Chron	Chan	C1	C2	C3	Tape grade
1	541	88.310	224.3	41	-38	30	12	48	1
2	542	89.147	224.5	42	17	2	30	12	48
3	543	90.115	224.5	43	79	2	30	12	48
4	544	91.099	224.8	44	115	2	30	12	48
5	545	92.143	224.8	45	0	2	30	12	48
6	546	92.900	225.4	46	16	1	30	12	48
7	547	93.900	225.8	47	2	2	30	12	48
8	548	94.986	226.0	48	68	2	30	12	48
9	549	95.729	226.3	49	26	2	30	12	48
10	550	96.634	226.0	50	-51	2	30	12	48
11	622	179.663	227.8	51	64	2	30	12	88
12	552	98.763	226.6	52	49	2	30	12	48
13	553	99.869	226.6	53	12	2	30	12	48
14	554	100.203	226.9	54	-12	1	30	12	48
15	555	101.678	227.3	55	65	2	30	12	48
16	556	102.615	227.3	56	42	2	30	12	48
17	557	103.456	227.4	57	87	2	30	12	48
18	558	104.871	227.4	58	21	2	30	12	48
19	559	105.742	227.2	59	-5	2	30	12	48
20	560	106.672	226.7	60	-13	2	30	12	48

FIELD DATA TABLE

Shot number 15 Shot point 19 Team 2
Shot time: 170:10:30: 0.010

Loc	Dist(km)	Azim	Unit	Chron	Chan	C1	C2	C3	Tape grade
1	521	69.843	218.0	21	-41	2	30	12	48
2	522	70.889	218.6	22	15	2	30	12	48
3	523	71.795	219.0	23	28	1	30	12	48
4	524	72.559	219.6	24	-7	1	30	12	48
5	525	73.144	219.6	25	63	2	30	12	48
6	526	74.352	219.5	26	12	2	30	12	48
7	527	75.489	219.5	27	8	2	30	12	48
8	528	76.492	220.0	28	-51	2	30	12	48
9	529	77.530	220.0	29	17	2	30	12	68
10	530	78.444	220.3	30	12	2	30	12	68
11	531	79.454	220.3	31	4	1	30	12	88
12	532	80.244	220.5	32	67	2	30	12	88
13	533	81.221	220.6	33	109	2	30	12	88
14	534	81.985	220.9	34	20	1	30	12	88
15	535	82.983	221.7	35	-62	2	30	12	68
16	536	83.872	222.1	36	9	2	30	12	68
17	537	84.736	222.6	37	5	2	30	12	48
18	538	85.293	222.8	38	1	2	30	12	48
19	539	86.491	223.5	39	-8	2	30	12	48
20	540	87.141	223.9	40	--	--	30	12	48

FIELD DATA TABLE

Shot number 15 Shot point 19 Team 4
Shot time: 170:10:30: 0.010

Loc	Dist(km)	Azim	Unit	Chron	Chan	C1	C2	C3	Tape grade
1	561	107.698	227.0	61	19	2	30	12	48
2	562	109.557	226.5	62	1	2	30	12	48
3	563	109.764	226.2	63	42	2	30	12	48
4	564	121.689	228.1	64	38	2	30	12	88
5	565	122.287	228.2	65	-10	2	30	12	88
6	566	123.684	228.3	66	12	2	30	12	88
7	567	124.607	228.3	67	-15	2	30	12	68
8	568	125.167	228.6	68	-11	2	30	12	68
9	569	126.725	228.9	69	12	2	30	12	48
10	570	127.671	229.0	70	68	2	30	12	48
11	571	128.194	229.0	71	34	2	30	12	48
12	572	129.557	229.2	72	32	2	30	12	48
13	573	130.401	229.2	73	-33	2	30	12	48
14	574	131.317	229.3	74	23	1	30	12	48
15	575	132.353	229.4	75	25	2	30	12	48
16	576	132.862	229.6	76	-9	2	30	12	48
17	577	134.136	229.7	77	-73	2	30	12	48
18	578	135.006	229.8	78	-14	2	30	12	48
19	579	136.574	229.8	79	202	2	30	12	48
20	580	137.279	229.8	80	19	2	30	12	48

FIELD DATA TABLE

Shot number 16 Shot point 34 Team 1
Shot time: 170:10:32: 0.008

Loc	Dist(km)	Azim	Unit	Chron	Chan	C1	C2	C3	Tape	grade
1	501	0.273	258.4	1	42	30	12	88	1	
2	502	1.658	194.0	2	68	1	30	12	88	0
3	503	2.902	192.0	3	24	3	30	12	68	0
4	504	4.079	193.9	4	-82	1	30	12	48	0
5	505	5.098	205.2	5	32	2	30	12	48	0
6	506	5.710	209.9	6	10	3	30	12	48	0
7	507	6.731	218.4	7	30	3	30	12	48	0
8	508	7.593	220.1	8	72	3	30	12	48	0
9	509	8.464	223.4	9	103	3	30	12	48	0
10	510	10.654	207.6	10	60	3	30	12	48	0
11	511	11.030	212.9	11	12	1	30	12	48	0
12	512	12.289	215.6	12	17	3	30	12	48	0
13	513	12.721	218.2	13	69	1	30	12	48	0
14	514	13.617	220.4	14	-52	3	30	12	48	0
15	515	14.571	222.1	15	10	3	30	12	48	0
16	516	15.946	224.0	16	-11	3	30	12	48	0
17	517	16.730	222.1	17	48	3	30	12	48	0
18	518	17.881	222.9	18	-49	1	30	12	48	0
19	621	131.249	232.4	19	82	2	30	12	88	0
20	520	19.808	222.3	20	31	1	30	12	48	0

FIELD DATA TABLE

Shot number 15 Shot point 19 Team 5
Shot time: 170:10:30: 0.010

Loc	Dist(km)	Azim	Unit	Chron	Chan	C1	C2	C3	Tape	grade
1	581	138.313	229.8	81	-38	2	30	12	48	0
2	582	139.366	229.9	82	-15	2	30	12	48	0
3	583	140.307	229.7	83	-19	2	30	12	48	0
4	584	141.246	229.8	84	-30	2	30	12	48	12
5	585	142.664	230.1	85	136	2	30	12	48	0
6	623	180.366	227.9	86	-11	2	30	12	88	0
7	587	144.358	229.8	87	3	30	12	48	12	
8	588	145.455	229.6	88	37	2	30	12	48	12
9	589	146.591	229.6	89	12	2	30	12	48	0
10	590	147.605	229.5	90	13	2	30	12	48	0
11	591	148.359	229.5	91	26	2	30	12	48	0
12	592	149.510	229.5	92	-6	2	30	12	48	0
13	593	150.083	229.7	93	21	2	30	12	48	0
14	594	151.135	229.5	94	43	2	30	12	48	0
15	595	152.499	228.8	95	-6	2	30	12	48	0
16	596	153.481	228.7	96	198	2	30	12	48	0
17	597	154.414	228.6	97	3	1	30	12	48	0
18	598	155.494	228.7	98	46	2	30	12	48	0
19	599	156.306	228.8	99	38	2	30	12	48	0
20	600	157.321	228.8	100	26	2	30	12	48	0

FIELD DATA TABLE

Shot number 16 Shot point 34 Team 2
Shot time: 170:10:32: 0.008

Loc	Dist(km)	Azim	Unit	Chron	Chan	C1	C2	C3	Tape	grade
1	521	20.655	224.4	21	-41	3	30	12	48	0
2	522	21.775	225.8	22	15	1	30	12	48	0
3	523	22.754	227.0	23	28	3	30	12	48	0
4	524	23.616	228.5	24	-7	1	30	12	48	0
5	525	24.200	228.3	25	63	1	30	12	48	0
6	526	25.375	227.6	26	12	1	30	12	48	0
7	527	26.492	227.1	27	8	1	30	12	48	0
8	528	27.585	228.3	28	-52	2	30	12	48	0
9	529	28.619	228.1	29	17	1	30	12	68	0
10	530	29.580	228.6	30	12	1	30	12	68	0
11	531	30.573	228.2	31	4	1	30	12	88	0
12	532	31.621	228.4	32	67	1	30	12	88	0
13	533	32.622	228.6	33	109	1	30	12	88	0
14	534	33.446	229.1	34	20	1	30	12	88	0
15	535	34.603	230.7	35	-62	1	30	12	68	0
16	536	35.590	231.5	36	9	1	30	12	68	0
17	537	36.586	232.5	37	5	1	30	12	48	0
18	538	37.176	232.7	38	1	2	30	12	48	0
19	539	38.548	233.9	39	-8	1	30	12	48	0
20	540	39.321	234.7	40	--	--	30	12	48	1

FIELD DATA TABLE

Shot number 15 Shot point 19 Team 6
Shot time: 170:10:30: 0.010

Loc	Dist(km)	Azim	Unit	Chron	Chan	C1	C2	C3	Tape	grade
1	601	158.292	228.3	101	36	1	30	12	48	0
2	602	159.783	228.4	102	8	2	30	12	48	0
3	603	160.422	228.2	103	1	2	30	12	48	0
4	604	161.480	228.4	104	-7	2	30	12	48	0
5	605	162.163	228.6	105	55	2	30	12	48	0
6	606	163.326	228.7	106	-8	2	30	12	48	0
7	607	164.176	228.7	107	75	1	30	12	48	0
8	608	165.471	228.5	108	-2	2	30	12	48	0
9	609	166.343	228.7	109	9	2	30	12	48	0
10	610	167.407	228.7	110	41	2	30	12	48	0
11				111	--	--	30	12	88	20
12	612	169.359	228.6	112	-13	2	30	12	88	0
13	613	170.320	228.5	113	--	2	30	12	48	0
14	614	171.961	228.6	114	-2	2	30	12	48	7
15	615	172.307	228.7	115	-149	30	12	48	1	
16	616	174.103	228.1	116	--	30	12	48	1	
17	617	174.699	228.1	117	86	30	12	48	1	
18	618	175.233	227.9	118	83	2	30	12	48	1
19	619	176.722	227.8	119	13	2	30	12	48	0
20	620	177.690	227.8	120	3	2	30	12	48	0

FIELD DATA TABLE

Shot number 16 Shot point 34 Team 3
Shot time: 170:10:32: 0.008

Loc	Dist(km)	Azim	Unit	Chron	Chan	C1	C2	C3	Tape grade
1	541	40.578	235.2	41	-38	30	12	48	1
2	542	41.474	235.4	42	17	1	30	12 48	0
3	543	42.436	235.2	43	79	1	30	12 48	0
4	544	43.476	235.5	44	115	1	30	12 48	0
5	545	44.518	235.3	45	0	1	30	12 48	0
6	546	45.463	236.4	46	16	1	30	12 48	0
7	547	46.565	236.9	47	2	2	30	12 48	17
8	548	47.696	237.0	48	68	1	30	12 48	0
9	549	48.540	237.5	49	26	1	30	12 48	0
10	550	49.342	236.8	50	-51	1	30	12 48	0
11	552	132.213	232.5	51	64	2	30	12 88	0
12	552	51.630	237.4	52	49	1	30	12 48	0
13	553	52.716	237.1	53	12	1	30	12 48	0
14	554	53.162	237.7	54	-12	1	30	12 48	0
15	555	54.757	238.2	55	65	1	30	12 48	0
16	556	55.680	238.0	56	42	2	30	12 48	1
17	557	56.526	237.9	57	87	1	30	12 48	0
18	558	57.919	237.6	58	21	1	30	12 48	0
19	559	58.725	237.2	59	-5	1	30	12 48	0
20	560	59.480	236.1	60	-13	2	30	12 48	0

FIELD DATA TABLE

Shot number 16 Shot point 34 Team 5
Shot time: 170:10:32: 0.008

Loc	Dist(km)	Azim	Unit	Chron	Chan	C1	C2	C3	Tape grade
1	581	91.621	237.5	81	-38	2	30	12 48	0
2	582	92.708	237.6	82	-15	2	30	12 48	12
3	583	93.586	237.3	83	-19	2	30	12 48	0
4	584	94.563	237.4	84	-30	2	30	12 48	12
5	585	96.069	237.7	85	136	2	30	12 48	0
6	623	132.931	232.6	86	-11	2	30	12 88	0
7	587	97.644	237.1	87	3	2	30	12 48	0
8	588	98.657	236.7	88	37	1	30	12 48	0
9	589	99.779	236.6	89	12	2	30	12 48	0
10	590	100.771	236.4	90	13	2	30	12 48	0
11	591	101.528	236.4	91	26	2	30	12 48	0
12	592	102.675	236.4	92	-6	2	30	12 48	0
13	593	103.299	236.6	93	21	2	30	12 48	0
14	594	104.270	236.2	94	43	2	30	12 48	0
15	595	105.427	235.2	95	-6	2	30	12 48	0
16	596	106.351	234.9	96	198	2	30	12 48	0
17	597	107.259	234.7	97	3	1	30	12 48	0
18	598	108.375	234.8	98	46	2	30	12 48	0
19	599	109.193	234.8	99	38	2	30	12 48	0
20	600	110.201	234.8	100	26	2	30	12 48	0

FIELD DATA TABLE

Shot number 16 Shot point 34 Team 4
Shot time: 170:10:32: 0.008

Loc	Dist(km)	Azim	Unit	Chron	Chan	C1	C2	C3	Tape grade
1	561	60.581	236.4	61	19	2	30	12 48	0
2	562	62.282	235.4	62	1	2	30	12 48	0
3	563	62.384	234.8	63	42	1	30	12 48	0
4	564	74.827	236.5	64	38	2	30	12 88	0
5	565	75.474	236.7	65	-10	2	30	12 88	0
6	566	76.872	236.6	66	12	2	30	12 88	0
7	567	77.812	236.6	67	-16	2	30	12 68	0
8	568	78.445	236.9	68	-11	2	30	12 68	0
9	569	79.849	237.3	69	12	2	30	12 48	1
10	570	80.812	237.3	70	68	2	30	12 48	0
11	571	81.332	237.3	71	34	2	30	12 48	0
12	572	82.749	237.4	72	32	2	30	12 48	0
13	573	83.587	237.4	73	-33	2	30	12 48	0
14	574	84.520	237.4	74	23	2	30	12 48	12
15	575	85.575	237.4	75	25	2	30	12 48	0
16	576	86.145	237.7	76	-9	1	30	12 48	0
17	577	87.471	237.8	77	-73	2	30	12 48	0
18	578	88.356	237.9	78	-14	2	30	12 48	1
19	579	89.911	237.7	79	20	1	30	12 48	0
20	580	90.598	237.6	80	19	2	30	12 48	1

FIELD DATA TABLE

Shot number 16 Shot point 34 Team 6
Shot time: 170:10:32: 0.008

Loc	Dist(km)	Azim	Unit	Chron	Chan	C1	C2	C3	Tape grade
1	601	111.019	234.0	101	36	1	30	12 48	0
2	602	112.536	234.1	102	8	2	30	12 48	0
3	603	113.135	233.9	103	1	2	30	12 48	0
4	604	114.239	234.0	104	-7	2	30	12 48	0
5	605	114.967	234.2	105	55	2	30	12 48	0
6	606	116.178	234.4	106	-8	2	30	12 48	0
7	607	117.018	234.4	107	75	2	30	12 48	0
8	608	118.253	234.0	108	-2	2	30	12 48	0
9	609	119.173	234.2	109	9	2	30	12 48	0
10	610	120.221	234.1	110	41	2	30	12 48	0
11	612	122.136	233.9	111	--	--	30	12 88	20
12	613	123.065	233.7	112	-13	2	30	12 48	0
13	614	124.147	233.9	113	--	2	30	12 48	0
14	615	125.111	233.9	114	-2	2	30	12 48	7
15	616	126.741	233.1	115	-149	--	30	12 48	1
16	617	127.330	233.0	116	--	--	30	12 48	1
17	618	128.807	232.7	117	86	2	30	12 48	1
18	619	129.276	232.6	118	83	2	30	12 48	0
19	620	130.220	232.5	119	13	2	30	12 48	0
20	620	130.220	232.5	120	3	2	30	12 48	12

FIELD DATA TABLE

Shot number 17 Shot point 31 Team 1
Shot time: 170:10:34; 0.009

Loc	Dist(km)	Azim	Unit	Chron	Chan	C1	C2	C3	Tape
									grade
1	501	132.977	52.5	1	42	30	12	88	1
2	502	131.948	53.0	2	68	2	30	12	88
3	503	131.063	53.4	3	24	2	30	12	68
4	504	130.108	53.7	4	-82	2	30	12	48
5	505	128.761	53.6	5	32	2	30	12	48
6	506	128.016	53.6	6	10	2	30	12	48
7	507	126.751	53.3	7	30	2	30	12	48
8	508	125.866	53.3	8	73	2	30	12	48
9	509	124.918	53.2	9	103	1	30	12	48
10	510	123.739	54.7	10	60	2	30	12	48
11	511	122.973	54.3	11	12	2	30	12	48
12	512	121.609	54.3	12	17	2	30	12	48
13	513	121.024	54.1	13	70	2	30	12	48
14	514	120.024	53.9	14	-52	2	30	12	48
15	515	119.003	53.8	15	10	2	30	12	48
16	516	117.558	53.7	16	-11	2	30	12	48
17	517	116.901	54.1	17	48	2	30	12	48
18	518	115.731	54.1	18	-49	2	30	12	48
19	621	2.007	61.1	19	82	1	30	12	88
20	520	113.898	54.4	20	31	2	30	12	48

FIELD DATA TABLE

Shot number 17 Shot point 31 Team 3
Shot time: 170:10:34; 0.009

Loc	Dist(km)	Azim	Unit	Chron	Chan	C1	C2	C3	Tape
									grade
1	541	92.812	51.4	41	-38	30	12	48	1
2	542	91.932	51.3	42	17	2	30	12	48
3	543	90.966	51.3	43	79	2	30	12	48
4	544	89.941	51.1	44	115	2	30	12	48
5	545	88.897	51.2	45	0	2	30	12	48
6	546	88.022	50.6	46	16	1	30	12	48
7	547	86.966	50.2	47	2	2	30	12	48
8	548	85.856	50.1	48	68	2	30	12	48
9	549	85.068	49.7	49	26	2	30	12	48
10	550	84.204	50.1	50	-51	2	30	12	48
11	622	1.019	58.1	51	64	3	30	12	88
12	552	82.003	49.5	52	49	2	30	12	48
13	553	80.900	49.6	53	12	2	30	12	48
14	554	80.528	49.1	54	-12	2	30	12	48
15	555	79.257	48.6	55	65	2	30	12	48
16	556	78.318	48.7	56	42	2	30	12	48
17	557	77.471	48.6	57	87	1	30	12	48
18	558	76.053	48.7	58	21	2	30	12	48
19	559	75.194	48.9	59	-5	2	30	12	48
20	560	74.321	49.7	60	-13	2	30	12	48

FIELD DATA TABLE

Shot number 17 Shot point 31 Team 2
Shot time: 170:10:34; 0.009

Loc	Dist(km)	Azim	Unit	Chron	Chan	C1	C2	C3	Tape
									grade
1	521	112.921	54.1	21	-41	2	30	12	48
2	522	111.732	53.9	22	15	2	30	12	48
3	523	110.700	53.7	23	28	2	30	12	48
4	524	109.779	53.5	24	-7	2	30	12	48
5	525	109.205	53.5	25	63	2	30	12	48
6	526	108.075	53.7	26	12	2	30	12	48
7	527	106.999	53.9	27	8	2	30	12	48
8	528	105.850	53.7	28	-52	2	30	12	48
9	529	104.838	53.8	29	17	2	30	12	68
10	530	103.857	53.7	30	12	2	30	12	68
11	531	102.894	53.9	31	4	2	30	12	88
12	532	101.840	53.9	32	67	2	30	12	88
13	533	100.841	53.9	33	109	2	30	12	88
14	534	99.991	53.7	34	20	2	30	12	88
15	535	98.772	53.2	35	-62	2	30	12	68
16	536	97.765	53.0	36	9	2	30	12	68
17	537	96.754	52.6	37	5	2	30	12	48
18	538	96.165	52.5	38	1	2	30	12	48
19	539	94.802	52.0	39	-8	2	30	12	48
20	540	94.049	51.6	40	--	2	30	12	48

FIELD DATA TABLE

Shot number 17 Shot point 31 Team 4
Shot time: 170:10:34; 0.009

Loc	Dist(km)	Azim	Unit	Chron	Chan	C1	C2	C3	Tape
									grade
1	561	73.259	49.3	61	19	2	30	12	48
2	562	71.460	50.1	62	1	2	30	12	48
3	563	71.312	50.6	63	42	2	30	12	48
4	564	59.146	47.5	64	38	1	30	12	88
5	565	58.544	47.2	65	-10	2	30	12	88
6	566	57.143	47.1	66	12	2	30	12	88
7	567	56.217	46.9	67	-16	2	30	12	68
8	568	55.662	46.4	68	-11	2	30	12	68
9	569	54.123	45.5	69	12	2	30	12	48
10	570	53.184	45.2	70	68	2	30	12	48
11	571	52.660	45.2	71	34	2	30	12	48
12	572	51.321	44.6	72	32	2	30	12	48
13	573	50.477	44.5	73	-33	2	30	12	48
14	574	49.572	44.2	74	23	2	30	12	48
15	575	48.550	43.8	75	25	2	30	12	48
16	576	48.081	43.2	76	-9	1	30	12	48
17	577	46.854	42.5	77	-73	2	30	12	48
18	578	46.004	42.2	78	-14	2	30	12	48
19	579	44.443	41.9	79	202	1	30	12	48
20	580	43.733	41.9	80	19	2	30	12	48

FIELD DATA TABLE

Shot number 18 Shot point 30 Team 1
Shot time: 170:12:32; 0.018

	Loc	Dist(km)	Azim	Unit	Chron	Chan	C1	C2	C3	Tape grade
1	501	181.375	52.7	1	44		30	12	88	1
2	502	180.354	53.0	2	70		30	12	88	12
3	503	179.474	53.3	3	25	2	30	12	68	0
4	504	178.521	53.5	4	-86	2	30	12	48	0
5	505	177.174	53.5	5	34	2	30	12	48	0
6	506	176.429	53.4	6	11	2	30	12	48	0
7	507	175.161	53.3	7	31	2	30	12	48	0
8	508	174.276	53.3	8	75		30	12	48	12
9	509	173.327	53.2	9	107		30	12	48	12
10	510	172.152	54.2	10	62	2	30	12	48	0
11	511	171.388	54.0	11	12	2	30	12	48	0
12	512	170.023	53.9	12	17	2	30	12	48	0
13	513	169.439	53.8	13	72		30	12	48	12
14	514	168.439	53.7	14	-54	2	30	12	48	0
15	515	167.417	53.6	15	11	2	30	12	48	0
16	516	165.972	53.5	16	-11	2	30	12	48	0
17	517	165.315	53.8	17	49	2	30	12	48	0
18	518	164.146	53.8	18	-51	2	30	12	48	0
19	621	50.554	53.4	19	85	1	30	12	88	0
20	520	162.313	54.0	20	32	2	30	12	48	0

FIELD DATA TABLE

Shot number 18 Shot point 30 Team 2
Shot time: 170:12:32; 0.018

	Loc	Dist(km)	Azim	Unit	Chron	Chan	C1	C2	C3	Tape grade
1	521	161.335	53.8	21	-43	2	30	12	48	0
2	522	160.146	53.6	22	16	2	30	12	48	0
3	523	159.114	53.5	23	29	1	30	12	48	0
4	524	158.191	53.3	24	-7	1	30	12	48	0
5	525	157.618	53.4	25	66	1	30	12	48	0
6	526	156.488	53.5	26	12	1	30	12	48	0
7	527	155.413	53.7	27	8	2	30	12	48	12
8	528	154.264	53.5	28	-56		30	12	68	0
9	529	153.252	53.6	29	18	2	30	12	68	0
10	530	152.271	53.5	30	12	2	30	12	68	0
11	531	151.308	53.6	31	4	1	30	12	88	0
12	532	150.255	53.6	32	70	2	30	12	88	0
13	533	149.256	53.6	33	113	2	30	12	88	0
14	534	148.405	53.5	34	21	2	30	12	88	0
15	535	147.183	53.2	35	-64	2	30	12	68	0
16	536	146.174	53.0	36	9	2	30	12	68	0
17	537	145.159	52.8	37	5	2	30	12	48	0
18	538	144.569	52.7	38	1	2	30	12	48	0
19	539	143.197	52.4	39	-8	2	30	12	48	0
20	540	142.437	52.1	40	--		30	12	48	1

FIELD DATA TABLE

Shot number 17 Shot point 31 Team 5
Shot time: 170:10:34; 0.009

	Loc	Dist(km)	Azim	Unit	Chron	Chan	C1	C2	C3	Tape grade
1	581	42.703	41.8	81	-38	2	30	12	48	0
2	582	41.694	41.2	82	-15		30	12	48	12
3	583	40.709	41.5	83	-19	2	30	12	48	0
4	584	39.819	40.8	84	-30	2	30	12	48	0
5	585	38.527	39.4	85	136	2	30	12	48	0
6	623	0.293	46.6	86	-11	3	30	12	88	0
7	587	36.727	40.2	87	3	2	30	12	48	0
8	588	35.937	40.9	88	12	1	30	12	48	0
9	589	34.423	40.7	89	13	1	30	12	48	0
10	590	33.402	40.6	90	26	2	30	12	48	0
11	591	32.661	40.3	91	3	2	30	12	48	0
12	592	31.524	39.9	92	43	2	30	12	48	0
13	593	31.029	38.9	93	-6	1	30	12	48	0
14	793	201.766	41.1	94	198	3	30	12	48	0
15	595	28.932	42.7	95	3	1	30	12	48	0
16	596	27.315	43.5	96	46	1	30	12	48	0
17	597	26.369	43.7	97	39	1	30	12	48	0
18	598	25.319	42.7	98	26	1	30	12	48	0
19	599	24.516	42.3	99	26	1	30	12	48	0
20	600	23.503	42.0	100	26	1	30	12	48	0

FIELD DATA TABLE

Shot number 17 Shot point 31 Team 6
Shot time: 170:10:34; 0.009

	Loc	Dist(km)	Azim	Unit	Chron	Chan	C1	C2	C3	Tape grade
1	601	22.441	45.4	101	36	1	30	12	48	0
2	602	20.961	44.3	102	8	2	30	12	48	21
3	603	20.305	45.2	103	1		30	12	48	0
4	604	19.269	43.6	104	-7	1	30	12	48	0
5	605	18.625	42.0	105	55	1	30	12	48	0
6	606	17.526	39.9	106	-8	1	30	12	48	0
7	607	16.675	39.7	107	75	1	30	12	48	0
8	608	15.319	41.0	108	-2	1	30	12	48	0
9	609	14.524	38.5	109	9	1	30	12	48	0
10	610	13.454	38.2	110	41	1	30	12	48	0
11				111	--		30	12	88	20
12	612	11.476	38.0	112	-13	1	30	12	48	0
13	613	10.479	38.7	113	--	3	30	12	48	0
14	614	9.542	34.9	114	-2		30	12	48	7
15	615	8.675	32.0	115	-150		30	12	48	1
16	616	6.597	42.1	116	--		30	12	48	1
17	617	5.996	42.2	117	86		30	12	48	1
18	618	5.443	48.2	118	83	3	30	12	48	0
19	619	3.959	51.1	119	13	3	30	12	48	0
20	620	3.024	56.8	120	3	1	30	12	48	0

FIELD DATA TABLE

Shot number 18 Shot point 30 Team 5
Shot time: 170:12:32: 0.018

Loc	Dist(km)	Azim	Unit	Chron	Chan	C1	C2	C3	Tape grade
1	581	90.514	47.8	81	-39	30	12	48	12
2	582	89.465	47.6	82	-16	30	12	48	12
3	583	88.520	47.8	83	-20	1	30	12	48
4	584	87.585	47.6	84	-31	30	12	48	12
5	585	86.185	47.0	85	141	2	30	12	48
6	623	48.856	53.1	86	-11	1	30	12	88
7	587	84.473	47.5	87	3	30	12	48	12
8	588	83.370	47.9	88	39	2	30	12	48
9	589	82.233	47.9	89	12	1	30	12	48
10	590	81.220	48.0	90	13	1	30	12	48
11	591	80.465	47.9	91	27	1	30	12	48
12	592	79.550	47.9	92	-6	2	30	12	48
13	593	78.979	47.6	93	22	2	30	12	48
14	594	77.920	48.0	94	45	1	30	12	48
15	595	76.579	49.3	95	-6	1	30	12	48
16	596	75.612	49.6	96	206	1	30	12	48
17	597	74.684	49.8	97	3	1	30	12	48
18	598	73.585	49.5	98	48	1	30	12	48
19	599	72.768	49.5	99	40	2	30	12	48
20	600	71.751	49.5	100	27	2	30	12	48

Loc	Dist(km)	Azim	Unit	Chron	Chan	C1	C2	C3	Tape grade
1	541	141.195	52.0	41	-40	30	12	48	1
2	542	140.311	51.9	42	17	2	30	12	48
3	543	139.347	51.9	43	82	2	30	12	48
4	544	138.318	51.8	44	119	2	30	12	48
5	545	137.275	51.8	45	0	30	12	48	3
6	546	136.383	51.5	46	16	30	12	48	12
7	547	135.316	51.2	47	2	30	12	48	7
8	548	134.201	51.2	48	71	2	30	12	48
9	549	133.400	50.9	49	27	2	30	12	48
10	550	132.550	51.2	50	-53	2	30	12	48
11	622	49.580	53.2	51	66	2	30	12	88
12	552	130.328	50.8	52	51	2	30	12	48
13	553	129.229	50.9	53	12	2	30	12	48
14	554	128.839	50.6	54	-13	30	12	48	12
15	555	127.309	50.3	55	68	2	30	12	48
16	556	126.374	50.3	56	44	30	12	48	3
17	557	125.528	50.3	57	91	2	30	12	48
18	558	124.119	50.4	58	22	2	30	12	48
19	559	123.273	50.5	59	-5	2	30	12	48
20	560	122.432	51.0	60	-13	2	30	12	48

FIELD DATA TABLE

Shot number 18 Shot point 30 Team 3
Shot time: 170:12:32: 0.018

FIELD DATA TABLE

Shot number 18 Shot point 30 Team 6
Shot time: 170:12:32: 0.018

Loc	Dist(km)	Azim	Unit	Chron	Chan	C1	C2	C3	Tape grade
1	601	70.851	50.6	101	37	1	30	12	48
2	602	69.337	50.4	102	9	2	30	12	48
3	603	68.721	50.8	103	1	1	30	12	48
4	604	67.629	50.4	104	-7	1	30	12	48
5	605	66.919	50.0	105	58	1	30	12	48
6	606	65.729	49.6	106	-8	2	30	12	48
7	607	64.880	49.7	107	78	1	30	12	48
8	608	63.608	50.2	108	-2	1	30	12	48
9	609	62.709	49.7	109	9	1	30	12	48
10	610	61.647	49.9	110	43	1	30	12	48
11				111	--	--	30	12	88
12	612	59.706	50.2	112	-14	2	30	12	48
13	613	58.760	50.5	113	--	1	30	12	48
14	614	57.691	50.1	114	-2	1	30	12	48
15	615	56.731	49.9	115	-155	30	12	48	1
16	616	55.049	51.8	116	--	30	12	48	1
17	617	54.459	51.9	117	90	1	30	12	48
18	618	53.987	52.6	118	86	1	30	12	48
19	619	52.521	52.9	119	14	1	30	12	48
20	620	51.584	53.3	120	3	30	12	48	3

FIELD DATA TABLE

Shot number 18 Shot point 30 Team 4
Shot time: 170:12:32: 0.018

Loc	Dist(km)	Azim	Unit	Chron	Chan	C1	C2	C3	Tape grade
1	561	121.362	50.8	61	20	2	30	12	48
2	562	119.595	51.3	62	1	2	30	12	48
3	563	119.464	51.6	63	44	2	30	12	48
4	564	107.230	50.0	64	39	2	30	12	88
5	565	106.613	49.8	65	-11	2	30	12	88
6	566	105.214	49.8	66	13	2	30	12	88
7	567	104.284	49.8	67	-16	2	30	12	68
8	568	103.702	49.5	68	-11	2	30	12	68
9	569	102.118	49.1	69	12	2	30	12	48
10	570	101.168	49.0	70	71	2	30	12	48
11	571	100.644	49.0	71	35	2	30	12	48
12	572	99.273	48.7	72	33	2	30	12	48
13	573	98.429	48.7	73	-35	1	30	12	48
14	574	97.511	48.6	74	24	1	30	12	48
15	575	96.472	48.5	75	26	1	30	12	48
16	576	95.962	48.2	76	-10	1	30	12	48
17	577	94.690	47.9	77	-76	1	30	12	48
18	578	93.822	47.8	78	-15	1	30	12	48
19	579	92.254	47.7	79	209	1	30	12	48
20	580	91.548	47.8	80	20	30	12	48	1

FIELD DATA TABLE

Shot number 19 Shot point 24 Team 3
Shot time: 175: 6:30: 0.010

Loc	Dist(km)	Azim	Unit	Chron	Chan	C1	C2	C3	Tape grade
1	832	163.992	176.9	41	-29	2	30	12 88	0
2	833	163.013	176.8	42	17		30	12 68	21
3	742	162.187	176.7	43	11	1	30	12 68	0
4	743	161.624	176.5	44	103	1	30	12 68	0
5	744	161.196	176.4	45	-3	1	30	12 48	0
6	745	159.738	176.2	46	39	1	30	12 48	0
7	746	158.364	176.0	47	1	1	30	12 48	0
8	747	157.598	175.8	48	47	2	30	12 48	0
9	748	156.506	176.2	49	19	1	30	12 48	0
10	749	155.668	175.9	50	-43	1	30	12 48	0
11	750	154.993	176.3	51	66	2	30	12 48	0
12	751	153.675	176.6	52	60	2	30	12 48	0
13	752	152.653	176.6	53	21		30	12 48	1
14	753	153.129	177.3	54	-14	2	30	12 48	0
15	754	151.808	176.7	55	69	1	30	12 48	0
16	755	151.493	177.4	56	41	2	30	12 48	0
17	756	150.716	177.6	57	98	2	30	12 48	0
18	757	149.742	177.5	58	21	2	30	12 48	0
19	758	148.194	177.5	59	-3		30	12 48	6
20	759	147.252	177.5	60	-11	2	30	12 48	0

FIELD DATA TABLE

Shot number 19 Shot point 24 Team 1
Shot time: 175: 6:30: 0.010

Loc	Dist(km)	Azim	Unit	Chron	Chan	C1	C2	C3	Tape grade
1	701	205.171	178.0	1	0	2	30	12 48	0
2	702	204.151	178.2	2	6	2	30	12 48	0
3	703	203.192	178.4	3	-4	2	30	12 48	0
4	704	202.155	178.6	4	-24	1	30	12 48	0/ 9
5	705	201.293	178.6	5	-3	2	30	12 48	0
6	706	200.317	178.7	6	-6	2	30	12 48	1
7	707	199.335	178.7	7	-7	2	30	12 48	0
8	708	198.359	178.7	8	6	2	30	12 48	0
9	710	197.167	178.7	9	112	2	30	12 68	0
10	711	196.227	178.8	10	66	2	30	12 88	0
11	712	195.083	178.8	11	21	2	30	12 88	0
12	713	194.002	178.8	12	0		30	12 88	1
13	714	192.746	178.8	13	72		30	12 68	12
14	715	192.094	178.9	14	-42		30	12 68	12
15	716	191.141	179.1	15	16		30	12 68	29
16	717	190.122	178.8	16	-8	2	30	12 48	0/ 9
17	718	189.209	178.8	17	47		30	12 48	12
18	719	188.353	178.9	18	-40		30	12 48	12
19	720	187.223	179.1	19	89	2	30	12 48	0
20	721	186.218	179.0	20	41	2	30	12 48	0

FIELD DATA TABLE

Shot number 19 Shot point 24 Team 4
Shot time: 175: 6:30: 0.010

Loc	Dist(km)	Azim	Unit	Chron	Chan	C1	C2	C3	Tape grade
1	760	147.320	176.9	61	20		30	12 48	12
2	762	145.517	177.5	62	0	2	30	12 48	0
3	761	145.457	177.0	63	11	2	30	12 48	0
4	763	144.152	176.9	64	40	2	30	12 48	0
5	764	143.254	176.7	65	-10	2	30	12 48	0
6	765	142.419	176.5	66	14	1	30	12 68	0
7	766	141.422	176.1	67	62	2	30	12 68	0
8	767	140.599	176.1	68	-5		30	12 88	12
9	768	139.258	176.2	69	5		30	12 88	1
10	769	138.256	176.1	70	67	2	30	12 88	1
11	770	137.578	176.5	71	48		30	12 68	1
12	771	136.246	176.9	72	30	2	30	12 68	0
13	772	134.964	177.0	73	-25	2	30	12 48	0
14	773	133.966	177.1	74	27	2	30	12 48	0
15	774	132.907	177.0	75	29	2	30	12 48	0
16	775	132.053	177.0	76	-5	1	30	12 48	0
17	776	131.220	177.1	77	12	2	30	12 48	0
18	777	129.546	177.3	78	-26	1	30	12 48	0
19	778	126.077	177.0	79	74	2	30	12 48	0
20				80	16				1

FIELD DATA TABLE

Shot number 19 Shot point 24 Team 2
Shot time: 175: 6:30: 0.010

Loc	Dist(km)	Azim	Unit	Chron	Chan	C1	C2	C3	Tape grade
1	722	185.331	178.8	21	-36	2	30	12 48	0
2	723	184.289	179.4	22	19	1	30	12 48	0
3	724	183.270	179.1	23	35	2	30	12 48	0
4	725	182.250	178.9	24	2	2	30	12 48	0
5	726	181.063	178.8	25	85	2	30	12 48	0
6	727	179.858	178.8	26	24	2	30	12 48	0
7	729	177.931	178.8	27	16	2	30	12 48	0
8	728	179.146	178.8	28	-109	2	30	12 48	0
9	730	177.071	178.5	29	21	2	30	12 48	0
10	731	175.969	178.0	30	10	2	30	12 48	0
11	732	175.126	177.6	31	2	2	30	12 48	0
12	733	174.640	177.4	32	59	2	30	12 48	0
13	734	173.451	177.2	33	125	2	30	12 48	0
14	735	172.548	176.9	34	23	2	30	12 48	0
15	736	170.759	176.6	35	-50	2	30	12 48	0
16	737	169.643	177.1	36	13	2	30	12 48	0
17	738	169.305	177.5	37	14	2	30	12 48	0
18	739	167.396	177.2	38	3	2	30	12 68	0
19	740	165.984	177.1	39	-2	2	30	12 68	0
20	741	165.335	177.0	40	--		30	12 68	1

FIELD DATA TABLE

Shot number 19 Shot point 24 Team 5
 Shot time: 175: 6:30: 0.010

Loc	Dist(km)	Azim	Unit	Chron	Chan	C1	C2	C3	Tape grade
1	779	123.653	176.4	81	30	2	30	12 48	0
2	780	122.640	176.4	82	-11	2	30	12 48	0
3	781	121.300	176.5	83	36	1	30	12 48	1
4	782	119.833	176.9	84	-23	1	30	12 48	0
5	783	118.257	177.5	85	38	1	30	12 48	0
6	784	117.199	177.4	86	-10	1	30	12 48	1
7	785	116.141	176.9	87	3	30	12 68	12	12
8	787	114.174	176.0	88	8	1	30	12 88	0
9				89	--				20
10	788	113.218	175.9	90	0	1	30	12 88	0
11	789	112.261	175.8	91	6	1	30	12 68	0
12	790	111.445	175.6	92	0	1	30	12 68	12
13	791	110.428	175.5	93	4	1	30	12 68	0
14	793	108.287	175.6	94	8	1	30	12 48	0
15	794	107.148	176.1	95	0	2	30	12 48	0
16	795	106.035	176.5	96	5	1	30	12 48	0
17	796	105.033	176.4	97	1	1	30	12 48	0
18	797	104.114	176.3	98	15	1	30	12 48	0
19	798	103.213	175.9	99	8	1	30	12 48	0
20	799	102.405	175.4	100	5	1	30	12 48	29

FIELD DATA TABLE

Shot number 20 Shot point 11 Team 1
 Shot time: 175: 6:32: 0.011

Loc	Dist(km)	Azim	Unit	Chron	Chan	C1	C2	C3	Tape grade
1	701	120.929	181.9	1	0	1	30	12 48	0
2	702	119.974	182.4	2	6	2	30	12 48	0
3	703	119.055	182.6	3	-4	1	30	12 48	0
4	704	118.084	183.1	4	-24	2	30	12 48	0
5	705	117.229	183.1	5	-3	2	30	12 48	0
6	706	116.264	183.2	6	-6	2	30	12 48	1
7	707	115.292	183.3	7	-7	2	30	12 48	0
8	708	114.321	183.3	8	6	2	30	12 48	0
9	710	113.136	183.4	9	112	2	30	12 68	0
10	711	112.217	183.6	10	67	2	30	12 88	0
11	712	111.102	183.8	11	21	2	30	12 88	0
12	713	110.047	183.9	12	0	0	30	12 88	1
13	714	108.762	183.8	13	73	30	12 68	12	0
14	715	108.139	184.0	14	-42	2	30	12 68	0
15	716	107.236	184.3	15	16	16	30	12 68	3
16	717	106.149	183.9	16	-8	2	30	12 48	0
17	718	105.245	184.0	17	47	40	30	12 48	12
18	719	104.413	184.2	18	-40	17	30	12 48	12
19	720	103.335	184.5	19	89	2	30	12 48	0
20	721	102.332	184.5	20	41	2	30	12 48	0

FIELD DATA TABLE

Shot number 19 Shot point 24 Team 6
 Shot time: 175: 6:30: 0.010

Loc	Dist(km)	Azim	Unit	Chron	Chan	C1	C2	C3	Tape grade
1	800	101.294	175.0	101	7	2	30	12 48	0
2	801	100.349	174.3	102	1	1	30	12 48	0
3	802	99.703	173.7	103	0	2	30	12 48	0
4	803	98.892	173.0	104	0	1	30	12 48	12
5	804	98.260	172.2	105	10	1	30	12 48	0
6	805	97.646	171.8	106	0	1	30	12 48	0
7	806	96.597	171.1	107	13	2	30	12 48	0
8	807	95.896	170.3	108	1	1	30	12 48	0
9	808	95.150	169.8	109	3	2	30	12 48	0
10	809	94.340	169.5	110	7	1	30	12 48	0
11	810	93.302	169.5	111	20	1	30	12 48	0
12	811	92.181	169.8	112	13	2	30	12 48	0
13	812	89.432	170.6	113	-5	1	30	12 48	0
14	813	88.450	171.3	114	0	1	30	12 48	0
15	814	87.427	171.7	115	2	1	30	12 48	12
16	815	86.538	172.1	116	4	1	30	12 48	0
17	816	85.585	172.4	117	13	1	30	12 48	0
18	817	84.087	172.8	118	14	1	30	12 48	0
19	835	0.000	180.0	119	0	1	30	12 48	29
20	834	37.614	167.4	120	0	1	30	12 48	0

FIELD DATA TABLE

Shot number 20 Shot point 11 Team 3
 Shot time: 175: 6:32: 0.011

Loc	Dist(km)	Azim	Unit	Chron	Chan	C1	C2	C3	Tape
1	832	79.779	181.6	41	-29	1	30	12 88	0
2	833	78.769	181.4	42	17	1	30	12 68	12
3	742	77.931	181.3	43	11	1	30	12 68	0
4	743	77.330	181.0	44	103	1	30	12 68	0
5	744	76.864	180.6	45	-3	1	30	12 48	0
6	745	75.381	180.4	46	39	1	30	12 48	0
7	746	73.960	180.0	47	1	1	30	12 48	0
8	747	73.166	179.7	48	47	1	30	12 48	0
9	748	72.138	180.5	49	19	1	30	12 48	0
10	749	71.244	179.9	50	-43	1	30	12 48	0
11	750	70.649	180.8	51	66	2	30	12 48	0
12	751	69.415	181.7	52	60	1	30	12 48	1
13	752	68.588	181.7	53	21	1	30	12 48	0
14	753	69.034	183.2	54	-14	1	30	12 48	0
15	754	67.560	181.9	55	69	1	30	12 48	0
16	755	67.431	183.5	56	41	1	30	12 48	0
17	756	66.711	184.0	57	98	2	30	12 48	0
18	757	65.733	184.1	58	21	1	30	12 48	0
19	758	64.180	184.1	59	-3	1	30	12 48	6
20	759	63.237	184.2	60	-11	1	30	12 48	0

FIELD DATA TABLE

Shot number 20 Shot point 11 Team 5
 Shot time: 175: 6:32: 0.011

Loc	Dist(km)	Azim	Unit	Chron	Chan	C1	C2	C3	Tape
1	779	39.460	184.8	81	30	1	30	12 48	0
2	780	38.436	184.9	82	-11	1	30	12 48	0
3	781	37.147	185.6	83	36	1	30	12 48	1
4	782	35.868	187.5	84	-23	1	30	12 48	0
5	783	34.560	189.9	85	38	1	30	12 48	0
6	784	33.467	189.9	86	-10	1	30	12 48	1
7	785	32.218	188.5	87	3	3	30	12 68	0
8	787	29.946	186.0	88	8	1	30	12 88	0
9				89	--				20
10	788	28.957	185.8	90	0	0	30	12 88	12
11	789	27.981	185.7	91	6	1	30	12 68	0
12	790	27.097	185.1	92	0	0	30	12 68	12
13	791	26.059	185.0	93	4	3	30	12 68	0
14	793	23.982	186.3	94	8	3	30	12 48	0
15	794	23.057	189.1	95	0	1	30	12 48	0
16	795	22.159	191.7	96	5	5	30	12 48	12
17	796	21.146	192.0	97	1	3	30	12 48	0
18	797	20.218	192.2	98	15	3	30	12 48	12
19	798	19.164	191.0	99	8	3	30	12 48	0
20	799	18.162	189.0	100	5	5	30	12 48	3

FIELD DATA TABLE

Shot number 20 Shot point 11 Team 4
 Shot time: 175: 6:32: 0.011

Loc	Dist(km)	Azim	Unit	Chron	Chan	C1	C2	C3	Tape
1	760	63.138	182.8	61	20	2	30	12 48	0
2	762	61.504	184.3	62	0	1	30	12 48	0
3	761	61.300	183.2	63	11	1	30	12 48	0
4	763	59.983	183.1	64	40	1	30	12 48	0
5	764	59.036	182.8	65	-10	1	30	12 48	0
6	765	58.149	182.3	66	14	1	30	12 68	0
7	766	57.068	181.5	67	62	1	30	12 68	0
8	767	56.229	181.4	68	-5	1	30	12 88	0
9	768	54.917	181.8	69	5	3	30	12 88	1
10	769	53.898	181.7	70	67	1	30	12 88	0
11	770	53.328	182.9	71	49	3	30	12 68	1
12	771	52.122	184.2	72	30	1	30	12 68	0
13	772	50.860	184.4	73	-25	1	30	12 48	0
14	773	49.906	184.9	74	27	3	30	12 48	0
15	774	48.816	184.8	75	29	2	30	12 48	0
16	775	47.988	185.1	76	-5	3	30	12 48	0
17	776	47.171	185.3	77	12	1	30	12 48	0
18	777	45.590	186.2	78	-26	1	30	12 48	0
19	778	42.047	186.0	79	74	1	30	12 48	0
20				80	16				1

FIELD DATA TABLE

Shot number 20 Shot point 11 Team 6
 Shot time: 175: 6:32: 0.011

Loc	Dist(km)	Azim	Unit	Chron	Chan	C1	C2	C3	Tape
1	800	16.905	187.4	101	7	1	30	12 48	0
2	801	15.744	183.8	102	1	3	30	12 48	0
3	802	14.954	180.1	103	0	3	30	12 48	0
4	803	14.051	175.6	104	0	2	30	12 48	0
5	804	13.416	170.0	105	10	3	30	12 48	0
6	805	12.846	166.8	106	0	3	30	12 48	0
7	806	11.986	160.2	107	13	3	30	12 48	0
8	807	11.624	153.2	108	1	3	30	12 48	0
9	808	11.192	148.1	109	3	3	30	12 48	0
10	809	10.648	144.0	110	7	3	30	12 48	0
11	810	9.731	141.2	111	21	3	30	12 48	0
12	811	8.525	140.3	112	13	3	30	12 48	0
13	812	5.514	137.4	113	-5	3	30	12 48	0
14	813	4.092	142.8	114	0	3	30	12 48	0
15	814	2.851	145.5	115	2	2	30	12 48	29
16	815	1.787	150.2	116	4	3	30	12 48	0
17	816	0.843	154.1	117	13	3	30	12 48	0
18	817	0.851	333.4	118	14	3	30	12 48	0
19	835	84.887	352.6	119	0	0	30	12 48	29
20	834	47.741	356.7	120	0	1	30	12 48	0

FIELD DATA TABLE

Shot number 21 Shot point 40 Team 1
 Shot time: 175: 6:34: 0.009

Loc	Dist(km)	Azim	Unit	Chron	Chan	C1	C2	C3	Tape grade
1	701	106.480	138.5	1	0	2	30	12 48	0
2	702	105.104	138.6	2	6	2	30	12 48	0
3	703	104.039	138.4	3	-4	2	30	12 48	0
4	704	102.691	138.4	4	-24	2	30	12 48	0
5	705	101.991	138.1	5	-3	2	30	12 48	0
6	706	101.178	137.8	6	-6	2	30	12 48	1
7	707	100.377	137.5	7	-7	2	30	12 48	0
8	708	99.623	137.1	8	6	2	30	12 48	0
9	710	98.698	136.7	9	112	2	30	12 68	0
10	711	97.849	136.4	10	67	2	30	12 68	0
11	712	96.795	136.1	11	21	2	30	12 88	0
12	713	95.818	135.8	12	0	0	30	12 88	1
13	714	95.167	135.1	13	73	2	30	12 68	12
14	715	94.488	135.0	14	-42	2	30	12 68	0
15	716	93.429	134.8	15	16	2	30	12 68	3
16	717	93.261	134.0	16	-8	2	30	12 48	0
17	718	92.565	133.7	17	47	2	30	12 48	12
18	719	91.799	133.4	18	-40	2	30	12 48	0
19	720	90.634	133.1	19	89	2	30	12 48	0
20	721	89.947	132.6	20	41	2	30	12 48	0

Shot number 21 Shot point 40 Team 3
 Shot time: 175: 6:34: 0.009

Loc	Dist(km)	Azim	Unit	Chron	Chan	C1	C2	C3	Tape grade
1	832	81.464	118.2	41	-29	1	30	12 88	0
2	833	81.294	117.5	42	17	1	30	12 68	12
3	742	81.008	116.9	43	11	1	30	12 68	0
4	743	81.145	116.4	44	103	1	30	12 68	0
5	744	81.375	116.0	45	-3	1	30	12 48	0
6	745	80.965	114.9	46	39	1	30	12 48	0
7	746	80.894	113.9	47	1	1	30	12 48	0
8	747	80.897	113.2	48	47	1	30	12 48	0
9	748	79.866	112.8	49	19	1	30	12 48	0
10	749	79.921	112.1	50	-43	1	30	12 48	0
11	750	78.919	112.0	51	66	2	30	12 48	0
12	751	77.453	111.4	52	60	1	30	12 48	0
13	752	77.158	110.8	53	21	1	30	12 48	1
14	753	75.631	111.6	54	-14	1	30	12 48	0
15	754	76.573	110.2	55	70	1	30	12 48	0
16	755	74.724	110.5	56	41	1	30	12 48	0
17	756	73.948	110.1	57	98	2	30	12 48	0
18	757	73.643	109.4	58	21	1	30	12 48	0
19	758	73.161	108.2	59	-3	1	30	12 48	6
20	759	72.860	107.5	60	-11	1	30	12 48	0

FIELD DATA TABLE

Shot number 21 Shot point 40 Team 2
 Shot time: 175: 6:34: 0.009

Loc	Dist(km)	Azim	Unit	Chron	Chan	C1	C2	C3	Tape grade
1	722	89.917	131.9	21	-36	2	30	12 48	0
2	723	87.656	132.3	22	19	2	30	12 48	12
3	724	87.775	131.3	23	36	2	30	12 48	0
4	725	87.481	130.6	24	2	2	30	12 48	0
5	726	86.921	129.9	25	85	2	30	12 48	0
6	727	86.129	129.3	26	24	2	30	12 48	0
7	729	84.922	128.3	27	16	2	30	12 48	0
8	728	85.720	128.9	28	-109	2	30	12 48	0
9	730	85.233	127.4	29	21	2	30	12 48	0
10	731	85.683	126.2	30	10	2	30	12 48	0
11	732	86.217	125.2	31	2	1	30	12 48	0
12	733	86.275	124.8	32	59	2	30	12 48	0
13	734	86.150	123.8	33	125	1	30	12 48	0
14	735	86.289	123.0	34	23	1	30	12 48	0
15	736	86.048	121.7	35	-50	2	30	12 48	0
16	737	84.182	121.6	36	13	2	30	12 48	0
17	738	82.897	122.0	37	14	2	30	12 48	0
18	739	82.575	120.5	38	3	2	30	12 68	0
19	740	82.156	119.5	39	-2	2	30	12 68	0
20	741	82.044	119.1	40	--	--	30	12 68	1

FIELD DATA TABLE

Shot number 21 Shot point 40 Team 4
 Shot time: 175: 6:34: 0.009

Loc	Dist(km)	Azim	Unit	Chron	Chan	C1	C2	C3	Tape grade
1	760	74.332	107.2	61	20	2	30	12 48	0
2	762	72.318	106.2	62	0	1	30	12 48	0
3	761	73.520	105.9	63	11	1	30	12 48	0
4	763	73.244	104.8	64	40	1	30	12 48	0
5	764	73.436	104.1	65	-10	1	30	12 48	0
6	765	73.685	103.3	66	14	1	30	12 68	0
7	766	74.255	102.4	67	62	1	30	12 68	0
8	767	74.206	101.7	68	-5	2	30	12 88	0
9	768	73.581	100.8	69	5	3	30	12 88	1
10	769	73.512	100.0	70	67	1	30	12 88	0
11	770	72.349	99.7	71	49	1	30	12 68	1
12	771	71.052	98.8	72	30	1	30	12 68	0
13	772	70.692	97.8	73	-25	1	30	12 48	0
14	773	70.224	97.0	74	27	1	30	12 48	0
15	774	70.318	96.1	75	29	2	30	12 48	0
16	775	70.034	95.5	76	-5	1	30	12 48	0
17	776	69.843	94.8	77	12	1	30	12 48	0
18	777	69.099	93.5	78	-26	1	30	12 48	0/9
19	778	69.467	90.6	79	74	1	30	12 48	0
20				80	16		30	12 48	1

FIELD DATA TABLE

Shot number 21 Shot point 40 Team 5
 Shot time: 175: 6:34: 0.009

Loc	Dist(km)	Azim	Unit	Chron	Chan	C1	C2	C3	Tape grade
1	779	70.558	81	30	1	30	12	48	0
2	780	70.651	82	-11	1	30	12	48	0
3	781	70.369	83	36	1	30	12	48	1
4	782	69.361	84	-23	1	30	12	48	0
5	783	68.199	85	38	1	30	12	48	0
6	784	68.529	86	-10	1	30	12	48	1
7	785	69.620	87	3	3	30	12	68	0
8	787	71.566	88	8	1	30	12	88	0
9			89	--					20
10	788	71.912	90	0	3	30	12	88	0
11	789	72.188	91	6	1	30	12	68	0
12	790	72.734	92	0	0	30	12	68	12
13	791	73.050	93	4	1	30	12	68	0
14	793	73.136	94	8	3	30	12	48	0
15	794	72.398	95	0	1	30	12	48	0
16	795	71.864	96	5	1	30	12	48	0
17	796	72.239	97	1	3	30	12	48	0
18	797	72.590	98	15	3	30	12	48	0
19	798	73.464	99	8	3	30	12	48	0
20	799	74.505	100	5	5	30	12	48	29

FIELD DATA TABLE

Shot number 22 Shot point 38 Team 1
 Shot time: 175: 6:36: 0.016

Loc	Dist(km)	Azim	Unit	Chron	Chan	C1	C2	C3	Tape grade
1	701	41.392	1	0	2	30	12	48	0
2	702	40.455	2	6	2	30	12	48	0
3	703	39.554	3	-4	2	30	12	48	0
4	704	38.627	4	-24	2	30	12	48	0
5	705	37.779	5	-3	2	30	12	48	0
6	706	36.825	6	-6	2	30	12	48	1
7	707	35.863	7	-7	2	30	12	48	0
8	708	34.900	8	6	2	30	12	48	0
9	710	33.727	9	112	2	30	12	68	0
10	711	32.833	10	67	2	30	12	88	0
11	712	31.759	11	21	2	30	12	88	0
12	713	30.745	12	0	0	30	12	88	1
13	714	29.433	13	73	2	30	12	68	12
14	715	28.853	14	-42	2	30	12	68	0
15	716	28.036	15	16	2	30	12	68	1
16	717	26.860	16	-8	2	30	12	48	0
17	718	25.981	17	47	1	30	12	48	0
18	719	25.198	18	-40	1	30	12	48	0
19	720	24.230	19	89	1	30	12	48	0
20	721	23.255	20	41	2	30	12	48	0

FIELD DATA TABLE

Shot number 21 Shot point 40 Team 6
 Shot time: 175: 6:34: 0.009

Loc	Dist(km)	Azim	Unit	Chron	Chan	C1	C2	C3	Tape grade
1	800	75.506	101	7	1	30	12	48	0
2	801	76.918	102	1	3	30	12	48	0
3	802	78.122	103	0	1	30	12	48	0
4	803	79.472	104	0	0	30	12	48	1
5	804	80.636	105	10	3	30	12	48	0
6	805	81.427	106	0	3	30	12	48	0
7	806	82.907	107	13	1	30	12	48	0
8	807	84.334	108	1	1	30	12	48	0
9	808	85.277	109	3	1	30	12	48	0
10	809	85.916	110	8	3	30	12	48	0
11	810	86.146	111	21	1	30	12	48	0
12	811	85.939	112	13	1	30	12	48	0
13	812	85.402	113	-5	1	30	12	48	0
14	813	84.611	114	0	1	30	12	48	0
15	814	84.246	115	2	1	30	12	48	29
16	815	83.964	116	4	1	30	12	48	0
17	816	83.874	117	13	2	30	12	48	0
18	817	83.948	118	14	2	30	12	48	0
19	835	139.412	119	0	0	30	12	48	29
20	834	112.860	120	0	1	30	12	48	0

FIELD DATA TABLE

Shot number 22 Shot point 38 Team 2
 Shot time: 175: 6:36: 0.016

Loc	Dist(km)	Azim	Unit	Chron	Chan	C1	C2	C3	Tape grade
1	722	22.183	21	-36	1	30	12	48	0
2	723	21.829	22	19	3	30	12	48	0
3	724	20.492	23	36	3	30	12	48	0
4	725	19.353	24	2	3	30	12	48	0
5	726	18.125	25	85	3	30	12	48	0
6	727	16.983	26	24	1	30	12	48	0
7	729	15.160	27	16	1	30	12	48	0
8	728	16.287	28	-110	1	30	12	48	0
9	730	13.953	29	21	1	30	12	48	0
10	731	12.452	30	10	3	30	12	48	0
11	732	11.325	31	2	3	30	12	48	0
12	733	10.768	32	59	3	30	12	48	0
13	734	9.492	33	126	3	30	12	48	0
14	735	8.542	34	23	1	30	12	48	0
15	736	6.807	35	-50	3	30	12	48	0
16	737	5.660	36	13	3	30	12	48	0
17	738	5.622	37	14	3	30	12	48	0
18	739	3.517	38	3	3	30	12	68	0
19	740	2.039	39	-2	3	30	12	68	0
20	741	1.339	40	--	--	30	12	68	1

FIELD DATA TABLE

Shot number 22 Shot point 38 Team 5
Shot time: 175: 6:36: 0.016

Loc	Dist(km)	Azim	Unit	Chron	Chan	C1	C2	C3	Tape grade
1	40.475	358.3	81	31	1	30	12	48	0
2	41.494	358.4	82	-11	1	30	12	48	0
3	42.828	358.0	83	36	1	30	12	48	1
4	44.289	356.7	84	-23	1	30	12	48	0
5	45.898	355.2	85	38	2	30	12	48	3
6	46.947	355.5	86	-10	1	30	12	48	0
7	47.988	356.8	87	3	3	30	12	68	0
8	50.000	358.9	88	8	2	30	12	88	20
9			89	--					
10	50.971	359.1	90	0	1	30	12	88	0
11	51.939	359.3	91	6	1	30	12	68	0
12	52.785	359.7	92	0	0	30	12	68	12
13	53.816	359.8	93	4	1	30	12	68	0
14	55.942	359.5	94	8	1	30	12	48	0
15	57.032	358.4	95	0	1	30	12	48	0
16	58.124	357.7	96	5	1	30	12	48	0
17	59.132	357.8	97	1	2	30	12	48	0
18	60.056	357.9	98	15	1	30	12	48	0
19	60.983	358.6	99	8	1	30	12	48	0
20	61.841	359.3	100	5		30	12	48	29

Shot number 22 Shot point 38 Team 3
Shot time: 175: 6:36: 0.016

Loc	Dist(km)	Azim	Unit	Chron	Chan	C1	C2	C3	Tape grade
1	0.107	285.0	41	-29	3	30	12	88	0
2	1.058	13.5	42	17	3	30	12	68	12
3	1.899	11.0	43	11	3	30	12	68	0
4	2.591	18.5	44	103	3	30	12	68	0
5	3.198	24.3	45	-3	3	30	12	48	0
6	4.673	19.6	46	39	3	30	12	48	0
7	6.206	20.4	47	1	3	30	12	48	0
8	7.077	20.9	48	47	3	30	12	48	0
9	7.793	11.4	49	20	3	30	12	48	0
10	8.833	15.0	50	-43	1	30	12	48	0
11	9.205	7.1	51	66	1	30	12	48	0
12	10.392	0.4	52	60	3	30	12	48	1
13	11.218	0.4	53	21	3	30	12	48	0
14	10.982	351.0	54	-14	3	30	12	48	0
15	12.255	359.3	55	70	3	30	12	48	0
16	12.640	350.7	56	41	3	30	12	48	0
17	13.480	348.9	57	99	2	30	12	48	0
18	14.435	349.8	58	21	3	30	12	48	0
19	15.961	350.9	59	-3		30	12	48	6
20	16.896	351.4	60	-11	1	30	12	48	0

FIELD DATA TABLE

Shot number 22 Shot point 38 Team 6
Shot time: 175: 6:36: 0.016

Loc	Dist(km)	Azim	Unit	Chron	Chan	C1	C2	C3	Tape grade
1	63.009	360.0	101	7	3	30	12	48	9
2	64.075	1.0	102	1	1	30	12	48	0
3	64.856	1.9	103	0	3	30	12	48	0
4	65.845	2.8	104	0	1	30	12	48	1
5	66.717	3.9	105	10	1	30	12	48	0
6	67.461	4.3	106	0	1	30	12	48	0
7	68.780	5.2	107	13	2	30	12	48	0
8	69.799	6.1	108	1	2	30	12	48	0
9	70.745	6.6	109	3	3	30	12	48	0
10	71.665	6.8	110	8	1	30	12	48	0
11	72.666	6.6	111	21	1	30	12	48	0
12	73.612	6.0	112	13	2	30	12	48	0
13	75.949	4.5	113	-5	1	30	12	48	0
14	76.657	3.5	114	11	0	30	12	48	29
15	77.518	2.8	115	2	2	30	12	48	0
16	78.284	2.2	116	4	1	30	12	48	0
17	79.057	1.8	117	13	1	30	12	48	0
18	80.379	1.3	118	14	1	30	12	48	0
19	164.025	356.9	119	0	0	30	12	48	29
20	127.155	359.7	120	0	2	30	12	48	0

FIELD DATA TABLE

Shot number 22 Shot point 38 Team 4
Shot time: 175: 6:36: 0.016

Loc	Dist(km)	Azim	Unit	Chron	Chan	C1	C2	C3	Tape grade
1	16.741	356.7	61	20	2	30	12	48	0
2	18.621	352.2	62	0	3	30	12	48	0
3	18.610	356.2	63	11	1	30	12	48	0
4	19.916	356.7	64	40	3	30	12	48	0
5	20.820	358.1	65	-10	1	30	12	48	0
6	21.675	359.4	66	14	1	30	12	68	0
7	22.736	1.6	67	62	1	30	12	68	0
8	23.576	1.8	68	-5	1	30	12	88	0
9	24.890	0.9	69	5	5	30	12	88	1
10	25.907	1.1	70	67	1	30	12	88	0
11	26.521	358.8	71	49	1	30	12	68	1
12	27.840	356.6	72	30	1	30	12	68	0
13	29.126	356.4	73	-25	1	30	12	48	0
14	30.130	355.9	74	27	1	30	12	48	0
15	31.186	356.5	75	29	2	30	12	48	0
16	32.045	356.2	76	-5	1	30	12	48	0
17	32.880	356.1	77	12	1	30	12	48	0
18	34.571	355.3	78	-26	1	30	12	48	0
19	38.032	356.5	79	74	2	30	12	48	1
20			80	16					

FIELD DATA TABLE

Shot number 23 Shot point 8 Team 1
Shot time: 175:10:30; 0.009

	Loc	Dist(km)	Azim	Unit	Chron	Chan	C1	C2	C3	Tape grade
1	701	167.185	180.4	1	3	2	30	12	48	0
2	702	166.204	180.7	2	13	2	30	12	48	0
3	703	165.268	180.9	3	0	2	30	12	48	0
4	704	164.269	181.2	4	-29	4	30	12	48	0
5	705	163.411	181.2	5	0	2	30	12	48	0
6	706	162.440	181.3	6	-5	2	30	12	48	1
7	707	161.463	181.3	7	-5	2	30	12	48	0
8	708	160.489	181.4	8	13	2	30	12	48	0
9	710	159.301	181.4	9	121	2	30	12	68	0
10	711	158.371	181.5	10	72	2	30	12	88	0
11	712	157.243	181.6	11	23	2	30	12	88	0
12	713	156.175	181.7	12	0	0	30	12	88	1
13	714	154.902	181.6	13	79	2	30	12	68	12
14	715	154.266	181.7	14	-45	2	30	12	68	0
15	716	153.339	181.9	15	17	1	30	12	68	1
16	717	152.282	181.7	16	-9	2	30	12	48	0
17	718	151.373	181.7	17	51	2	30	12	48	0
18	719	150.530	181.8	18	-43	1	30	12	48	0
19	720	149.426	182.0	19	96	2	30	12	48	0
20	721	148.421	182.0	20	45	2	30	12	48	0

FIELD DATA TABLE

Shot number 23 Shot point 8 Team 3
Shot time: 175:10:30; 0.009

	Loc	Dist(km)	Azim	Unit	Chron	Chan	C1	C2	C3	Tape grade
1	832	125.891	179.8	41	-32	1	30	12	88	0
2	833	124.894	179.6	42	19	30	12	68	6	6
3	742	124.061	179.5	43	12	1	30	12	68	0
4	743	123.475	179.3	44	112	1	30	12	68	0
5	744	123.023	179.1	45	-3	2	30	12	48	0
6	745	121.550	179.0	46	43	2	30	12	48	0
7	746	120.147	178.7	47	1	1	30	12	48	0
8	747	119.363	178.5	48	51	1	30	12	48	0
9	748	118.314	179.0	49	21	1	30	12	48	0
10	749	117.440	178.6	50	-46	1	30	12	48	0
11	750	116.817	179.1	51	72	2	30	12	48	0
12	751	115.550	179.6	52	65	2	30	12	48	0
13	752	114.726	179.6	53	23	30	12	48	1	1
14	753	113.098	180.5	54	-16	1	30	12	48	0
15	754	113.691	179.7	55	75	1	30	12	48	0
16	755	113.479	180.7	56	44	1	30	12	48	0
17	756	112.731	181.0	57	107	2	30	12	48	0
18	757	111.755	180.9	58	23	1	30	12	48	0
19	758	110.204	180.9	59	-3	30	12	48	6	6
20	759	109.261	181.0	60	-12	2	30	12	48	0

FIELD DATA TABLE

Shot number 23 Shot point 8 Team 2
Shot time: 175:10:30; 0.009

	Loc	Dist(km)	Azim	Unit	Chron	Chan	C1	C2	C3	Tape grade
1	722	147.495	181.7	21	-39	2	30	12	48	0
2	723	146.565	182.6	22	20	1	30	12	48	0
3	724	145.488	182.2	23	38	2	30	12	48	0
4	725	144.442	182.0	24	3	2	30	12	48	0
5	726	143.240	181.9	25	92	2	30	12	48	0
6	727	142.036	181.9	26	26	2	30	12	48	0
7	729	140.109	181.9	27	17	2	30	12	48	0
8	728	141.321	181.9	28	-118	2	30	12	48	0
9	730	139.192	181.5	29	23	2	30	12	48	0
10	731	138.016	180.9	30	10	2	30	12	48	0
11	732	137.109	180.4	31	2	1	30	12	48	0
12	733	136.602	180.2	32	64	2	30	12	48	0
13	734	135.379	179.9	33	136	2	30	12	48	0
14	735	134.438	179.6	34	25	2	30	12	48	0
15	736	132.605	179.2	35	-54	3	30	12	48	0
16	737	131.558	179.8	36	14	2	30	12	48	0
17	738	131.285	180.4	37	15	30	12	48	29	29
18	739	129.333	180.1	38	4	1	30	12	48	0
19	740	127.902	179.9	39	-2	2	30	12	68	0
20	741	127.240	179.8	40	--	--	30	12	68	1

FIELD DATA TABLE

Shot number 23 Shot point 8 Team 4
Shot time: 175:10:30; 0.009

	Loc	Dist(km)	Azim	Unit	Chron	Chan	C1	C2	C3	Tape grade
1	760	109.241	180.2	61	22	2	30	12	48	0
2	762	107.526	181.0	62	0	1	30	12	48	0
3	761	107.391	180.3	63	12	2	30	12	48	0
4	763	106.079	180.3	64	43	1	30	12	48	0
5	764	105.154	180.0	65	-11	1	30	12	48	0
6	765	104.291	179.8	66	15	1	30	12	68	0
7	766	103.246	179.3	67	67	2	30	12	68	0
8	767	102.414	179.2	68	-6	1	30	12	88	0
9	768	101.090	179.4	69	5	30	12	88	1	1
10	769	100.078	179.3	70	73	1	30	12	88	0
11	770	99.460	179.9	71	53	30	12	68	1	1
12	771	98.192	180.6	72	33	1	30	12	68	0
13	772	96.918	180.7	73	-27	1	30	12	48	0
14	773	95.941	180.9	74	30	1	30	12	48	0
15	774	94.866	180.8	75	32	2	30	12	48	0
16	775	94.023	180.9	76	-6	30	12	48	29	29
17	776	93.196	180.9	77	13	1	30	12	48	0
18	777	91.563	181.3	78	-23	1	30	12	48	0
19	778	88.053	181.1	79	80	1	30	12	48	0
20				80	17					1

FIELD DATA TABLE

Shot number 24 Shot point 12 Team 1
Shot time: 175:10:32: 0.014

Loc	Dist(km)	Azim	Unit	Chron	Chan	C1	C2	C3	Tape grade	
1	701	91.150	180.5	1	3	2	30	12	48	0
2	702	90.173	181.1	2	13	2	30	12	48	0
3	703	89.242	181.5	3	0	2	30	12	48	0
4	704	88.254	182.1	4	-29	2	30	12	48	0
5	705	87.398	182.1	5	0	2	30	12	48	0
6	706	86.430	182.3	6	-5	2	30	12	48	1
7	707	85.455	182.3	7	-5	2	30	12	48	0
8	708	84.483	182.4	8	13	2	30	12	48	0
9	710	83.296	182.5	9	121	2	30	12	68	0
10	711	82.372	182.7	10	72	2	30	12	88	0
11	712	81.252	182.9	11	23	2	30	12	88	0
12	713	80.192	183.2	12	0	0	30	12	88	1
13	714	79.081	183.0	13	79	2	30	12	68	0
14	715	78.452	183.2	14	-45	2	30	12	68	0
15	716	77.540	183.7	15	17	2	30	12	68	1
16	717	76.460	183.1	16	-9	2	30	12	48	0
17	718	75.552	183.2	17	51	1	30	12	48	12
18	719	74.714	183.4	18	-43	1	30	12	48	0
19	720	73.627	183.9	19	97	2	30	12	48	0
20	721	72.622	184.0	20	45	2	30	12	48	0

FIELD DATA TABLE

Shot number 24 Shot point 12 Team 2
Shot time: 175:10:32: 0.014

Loc	Dist(km)	Azim	Unit	Chron	Chan	C1	C2	C3	Tape grade	
1	722	71.670	183.4	21	-39	2	30	12	48	0
2	723	70.818	185.1	22	20	1	30	12	48	0
3	724	69.696	184.3	23	38	2	30	12	48	0
4	725	68.631	184.0	24	3	2	30	12	48	0
5	726	67.419	183.8	25	92	2	30	12	48	0
6	727	66.215	183.9	26	26	2	30	12	48	0
7	729	64.286	184.0	27	17	1	30	12	48	0
8	728	65.497	183.9	28	-118	1	30	12	48	0
9	730	63.334	183.0	29	23	2	30	12	48	0
10	731	62.126	181.8	30	10	2	30	12	48	0
11	732	61.206	180.6	31	2	2	30	12	48	0
12	733	60.697	180.2	32	64	2	30	12	48	0
13	734	59.474	179.5	33	136	2	30	12	48	0
14	735	58.540	178.7	34	25	2	30	12	48	0
15	736	56.723	177.7	35	-54	3	30	12	48	0
16	737	55.647	179.3	36	14	2	30	12	48	0
17	738	55.370	180.7	37	15	2	30	12	48	0
18	739	53.414	179.8	38	4	2	30	12	68	0
19	740	51.982	179.4	39	-2	2	30	12	68	0
20	741	51.321	179.1	40	--	--	30	12	68	1

FIELD DATA TABLE

Shot number 23 Shot point 8 Team 5
Shot time: 175:10:30: 0.009

Loc	Dist(km)	Azim	Unit	Chron	Chan	C1	C2	C3	Tape grade	
1	779	85.550	180.4	81	33	1	30	12	48	0
2	780	84.531	180.3	82	-12	1	30	12	48	0
3	781	83.211	180.6	83	39	3	30	12	48	1
4	782	81.820	181.3	84	-25	1	30	12	48	0
5	783	80.344	182.2	85	41	1	30	12	48	0
6	784	79.447	182.1	86	-11	1	30	12	48	1
7	785	78.309	181.5	87	4	1	30	12	68	0
8	787	76.208	180.2	88	11	1	30	12	68	0
9				89	--	0	30	12	88	0
10	788	75.233	180.1	90	0	1	30	12	88	0
11	789	74.263	180.0	91	8	1	30	12	68	0
12	790	73.414	179.7	92	0	0	30	12	68	12
13	791	72.383	179.6	93	6	1	30	12	68	0
14	793	70.258	179.9	94	12	3	30	12	48	0
15	794	69.192	180.7	95	0	1	30	12	48	0
16	795	68.143	181.4	96	6	3	30	12	48	0
17	796	67.129	181.4	97	2	1	30	12	48	0
18	797	66.198	181.3	98	22	1	30	12	48	0
19	798	65.240	180.8	99	11	3	30	12	48	0
20	799	64.361	180.1	100	7	7	30	12	48	1

FIELD DATA TABLE

Shot number 23 Shot point 8 Team 6
Shot time: 175:10:30: 0.009

Loc	Dist(km)	Azim	Unit	Chron	Chan	C1	C2	C3	Tape grade	
1	800	63.191	179.4	101	10	1	30	12	48	0
2	801	62.197	178.4	102	2	3	30	12	48	0
3	802	61.436	177.4	103	0	3	30	12	48	0
4	803	60.554	176.4	104	-2	0	30	12	48	12
5	804	59.850	175.1	105	15	3	30	12	48	0
6	805	59.203	174.5	106	0	3	30	12	48	0
7	806	58.100	173.3	107	19	1	30	12	48	0
8	807	57.354	172.0	108	1	1	30	12	48	0
9	808	56.586	171.2	109	4	1	30	12	48	0
10	809	55.764	170.7	110	11	3	30	12	48	0
11	810	54.723	170.7	111	30	3	30	12	48	0
12	811	53.610	171.2	112	19	1	30	12	48	0
13	812	50.893	172.7	113	-7	1	30	12	48	0
14	813	49.955	174.0	114	0	1	30	12	48	0
15	814	48.967	174.9	115	4	1	30	12	48	0
16	815	48.111	175.7	116	6	1	30	12	48	0
17	816	47.284	176.2	117	19	1	30	12	48	0
18	817	45.723	177.0	118	21	1	30	12	48	0
19	835	38.824	347.8	119	0	0	30	12	48	29
20	834	1.238	360.0	120	-2	1	30	12	48	0

FIELD DATA TABLE

Shot number 24 Shot point 12 Team 5
Shot time: 175:10:32; 0.014

Loc	Dist(km)	Azim	Unit	Chron	Chan	C1	C2	C3	Tape
1	779	9.537	181.3	81	33	3	30	12 48	0
2	780	8.514	181.0	82	-12	1	30	12 48	0
3	781	7.204	183.9	83	39	1	30	12 48	1
4	782	5.988	195.3	84	-25	1	30	12 48	0
5	783	5.134	214.0	85	41	3	30	12 48	0
6	784	4.142	219.7	86	-11	4	30	12 68	1
7	785	2.671	219.0	87	4	3	30	12 68	0
8	787	0.000	180.0	88	11	1	30	12 88	0
9	788	0.995	11.4	89	--	0	30	12 88	20
10	789	1.969	9.1	91	8	1	30	12 68	0
11	790	2.883	14.3	92	0	0	30	12 68	12
12	791	3.916	12.3	93	6	1	30	12 68	0
13	793	5.967	4.4	94	12	3	30	12 48	0
14	794	7.043	355.4	95	0	1	30	12 48	0
15	795	8.203	350.3	96	6	3	30	12 48	0
16	796	9.187	352.0	97	2	1	30	12 48	0
17	797	10.096	353.3	98	22	1	30	12 48	0
18	798	10.987	357.1	99	11	3	30	12 48	0
19	799	11.849	1.3	100	7	0	30	12 48	1
20									

Shot number 24 Shot point 12 Team 3
Shot time: 175:10:32; 0.014

Loc	Dist(km)	Azim	Unit	Chron	Chan	C1	C2	C3	Tape
1	832	49.971	179.0	41	-32	1	30	12 88	0
2	833	48.977	178.6	42	19	30	12 68	12	0
3	742	48.145	178.4	43	12	1	30	12 68	0
4	743	47.568	177.8	44	112	2	30	12 68	0
5	744	47.130	177.2	45	-3	2	30	12 48	0
6	745	45.665	176.8	46	43	2	30	12 48	0
7	746	44.287	175.9	47	1	2	30	12 48	0
8	747	43.521	175.4	48	51	1	30	12 48	0
9	748	42.425	176.6	49	21	1	30	12 48	0
10	749	41.586	175.5	50	-46	1	30	12 48	0
11	750	40.912	177.0	51	72	2	30	12 48	0
12	751	39.613	178.5	52	65	1	30	12 48	1
13	752	38.787	178.4	53	23	30	12 48	1	0
14	753	39.149	181.1	54	-16	1	30	12 48	0
15	754	37.745	178.7	55	75	1	30	12 48	0
16	755	37.532	181.6	56	44	1	30	12 48	0
17	756	36.794	182.5	57	107	2	30	12 48	0
18	757	35.816	182.5	58	23	1	30	12 48	0
19	758	34.262	182.5	59	-3	30	12 48	29	0
20	759	33.317	182.6	60	-12	1	30	12 48	0

FIELD DATA TABLE

Shot number 24 Shot point 12 Team 6
Shot time: 175:10:32; 0.014

Loc	Dist(km)	Azim	Unit	Chron	Chan	C1	C2	C3	Tape
1	800	13.053	4.1	101	10	1	30	12 48	0
2	801	14.227	8.4	102	2	3	30	12 48	0
3	802	15.149	11.8	103	0	1	30	12 48	0
4	803	16.322	14.9	104	-2	1	30	12 48	12
5	804	17.499	18.2	105	15	1	30	12 48	0
6	805	18.305	19.3	106	0	1	30	12 48	0
7	806	19.850	21.2	107	19	1	30	12 48	0
8	807	21.139	23.3	108	1	1	30	12 48	0
9	808	22.214	24.1	109	4	1	30	12 48	0
10	809	23.162	23.9	110	11	1	30	12 48	0
11	810	24.041	22.6	111	30	1	30	12 48	0
12	811	24.755	20.3	112	19	1	30	12 48	0
13	812	26.625	14.9	113	-7	1	30	12 48	0
14	813	27.108	11.9	114	1	1	30	12 48	0
15	814	27.844	9.8	115	4	1	30	12 48	0
16	815	28.516	8.1	116	6	1	30	12 48	0
17	816	29.234	6.8	117	19	1	30	12 48	0
18	817	30.667	5.1	118	21	1	30	12 48	0
19	835	114.174	356.0	119	0	1	30	12 48	29
20	834	77.446	0.2	120	-2	1	30	12 48	0

FIELD DATA TABLE

Shot number 24 Shot point 12 Team 4
Shot time: 175:10:32; 0.014

Loc	Dist(km)	Azim	Unit	Chron	Chan	C1	C2	C3	Tape
1	760	33.277	180.0	61	22	2	30	12 48	0
2	762	31.581	182.8	62	0	1	30	12 48	0
3	761	31.423	180.5	63	12	1	30	12 48	0
4	763	30.108	180.3	64	43	1	30	12 48	0
5	764	29.184	179.5	65	-11	1	30	12 48	0
6	765	28.326	178.5	66	15	1	30	12 68	0
7	766	27.309	176.7	67	67	1	30	12 68	0
8	767	26.483	176.3	68	-6	1	30	12 88	0
9	768	25.141	176.9	69	5	30	12 88	1	0
10	769	24.134	176.5	70	73	1	30	12 88	0
11	770	23.479	179.0	71	53	30	12 68	1	0
12	771	22.210	181.7	72	33	1	30	12 68	0
13	772	20.938	182.3	73	-27	3	30	12 48	0
14	773	19.971	183.3	74	30	1	30	12 48	0
15	774	18.887	182.8	75	32	1	30	12 48	0
16	775	18.051	183.6	76	-6	30	12 48	29	0
17	776	17.230	184.1	77	13	1	30	12 48	0
18	777	15.645	186.8	78	-28	1	30	12 48	0
19	778	12.101	186.3	79	80	1	30	12 48	0
20				80	17	0	30	12 48	1

FIELD DATA TABLE

Shot number 25 Shot point 37 Team 1
Shot time: 175:10:36: 0.016

Loc	Dist(km)	Azim	Unit	Chron	Chan	C1	C2	C3	Tape grade
1	701	11.056	162.0	1	4	3	30	12 48	0
2	702	9.835	165.6	2	13	3	30	12 48	0
3	703	8.789	167.4	3	0	3	30	12 48	0
4	704	7.630	172.3	4	-29	3	30	12 48	0
5	705	6.766	172.0	5	0	3	30	12 48	0
6	706	5.782	171.9	6	-5	3	30	12 48	1
7	707	4.795	171.5	7	-5	3	30	12 48	0
8	708	3.824	170.0	8	13	3	30	12 48	0
9	710	2.640	167.0	9	121	3	30	12 68	0
10	711	1.673	167.7	10	72	3	30	12 88	0
11	712	0.496	176.9	11	23	3	30	12 88	0
12	713	0.638	336.1	12	0	30	12 88	1	0
13	714	1.853	3.6	13	79	3	30	12 68	0
14	715	2.504	355.5	14	-45	3	30	12 68	1
15	716	3.523	347.7	15	18	3	30	12 68	0
16	717	4.478	0.6	16	-9	3	30	12 48	0
17	718	5.391	359.7	17	51	3	30	12 48	0
18	719	6.250	357.5	18	-43	3	30	12 48	0
19	720	7.413	353.7	19	97	3	30	12 48	0
20	721	8.415	354.5	20	45	3	30	12 48	0

FIELD DATA TABLE

Shot number 25 Shot point 37 Team 3
Shot time: 175:10:36: 0.016

Loc	Dist(km)	Azim	Unit	Chron	Chan	C1	C2	C3	Tape grade
1	832	31.285	9.4	41	-32	1	30	12 88	0
2	833	32.331	9.8	42	19	1	30	12 68	12
3	742	33.174	9.7	43	12	1	30	12 68	0
4	743	33.837	10.3	44	112	1	30	12 68	0
5	744	34.379	11.0	45	-3	1	30	12 48	0
6	745	35.884	11.0	46	43	1	30	12 48	0
7	746	37.390	11.4	47	1	1	30	12 48	0
8	747	38.241	11.7	48	51	1	30	12 48	0
9	748	39.065	10.0	49	21	1	30	12 48	0
10	749	40.078	10.8	50	-46	3	30	12 48	0
11	750	40.472	9.1	51	72	1	30	12 48	0
12	751	41.565	7.3	52	65	1	30	12 48	0
13	752	42.386	7.2	53	23	30	12 48	1	0
14	753	41.829	4.8	54	-16	1	30	12 48	0
15	754	43.387	6.7	55	76	1	30	12 48	0
16	755	43.424	4.2	56	44	1	30	12 48	0
17	756	44.142	3.4	57	107	2	30	12 48	0
18	757	45.120	3.4	58	23	3	30	12 48	0
19	758	46.674	3.3	59	-3	30	12 48	29	0
20	759	47.618	3.2	60	-12	1	30	12 48	0

FIELD DATA TABLE

Shot number 25 Shot point 37 Team 2
Shot time: 175:10:36: 0.016

Loc	Dist(km)	Azim	Unit	Chron	Chan	C1	C2	C3	Tape grade
1	722	9.278	359.9	21	-39	3	30	12 48	0
2	723	10.516	348.1	22	20	3	30	12 48	0
3	724	11.375	354.7	23	38	3	30	12 48	0
4	725	12.368	357.5	24	3	3	30	12 48	0
5	726	13.554	359.0	25	92	3	30	12 48	0
6	727	14.762	359.0	26	26	3	30	12 48	0
7	729	16.693	359.2	27	17	1	30	12 48	0
8	728	15.476	359.3	28	-119	3	30	12 48	0
9	730	17.600	2.8	29	23	3	30	12 48	0
10	731	18.870	7.1	30	10	3	30	12 48	0
11	732	19.957	10.5	31	2	3	30	12 48	0
12	733	20.537	11.5	32	64	3	30	12 48	0
13	734	21.882	12.6	33	136	3	30	12 48	0
14	735	22.990	14.1	34	25	3	30	12 48	0
15	736	25.008	15.1	35	-54	3	30	12 48	0
16	737	25.662	11.1	36	14	1	30	12 48	0
17	738	25.709	8.0	37	15	1	30	12 48	0
18	739	27.765	9.2	38	4	1	30	12 68	0
19	740	29.239	9.4	39	-2	1	30	12 68	0
20	741	29.937	9.7	40	--	--	30	12 68	1

FIELD DATA TABLE

Shot number 25 Shot point 37 Team 4
Shot time: 175:10:36: 0.016

Loc	Dist(km)	Azim	Unit	Chron	Chan	C1	C2	C3	Tape grade
1	760	47.737	5.1	61	22	2	30	12 48	0
2	762	49.354	3.1	62	0	1	30	12 48	0
3	761	49.562	4.6	63	12	1	30	12 48	0
4	763	50.879	4.6	64	43	1	30	12 48	0
5	764	51.839	5.0	65	-11	1	30	12 48	0
6	765	52.745	5.4	66	15	1	30	12 68	0
7	766	53.879	6.2	67	67	1	30	12 68	0
8	767	54.725	6.3	68	-6	1	30	12 88	0
9	768	56.002	5.7	69	5	1	30	12 88	1
10	769	57.025	5.8	70	73	1	30	12 88	0
11	770	57.538	4.6	71	53	1	30	12 68	1
12	771	58.732	3.5	72	33	1	30	12 68	0
13	772	59.998	3.2	73	-27	1	30	12 48	0
14	773	60.963	2.9	74	30	1	30	12 48	0
15	774	62.047	3.0	75	32	1	30	12 48	0
16	775	62.884	2.8	76	-6	1	30	12 48	29
17	776	63.708	2.7	77	13	1	30	12 48	0
18	777	65.331	2.1	78	-28	1	30	12 48	0
19	778	68.856	2.4	79	80	2	30	12 48	0
20				80	17				1

FIELD DATA TABLE

Shot number 26 Shot point 19 Team 1
Shot time: 176: 6:30: 0.009

Loc	Dist(km)	Azim	Unit	Chron	Chan	C1	C2	C3	Tape grade
1	66.350	181.9	1	27	1	30	12	48	0
2	65.396	182.7	2	54	2	30	12	48	0
3	64.480	183.2	3	16	1	30	12	48	0
4	63.520	184.1	4	-62	2	30	12	48	0
5	62.666	184.2	5	19	2	30	12	48	0
6	61.703	184.4	6	6	6	30	12	48	1
7	60.732	184.6	7	5	1	30	12	48	0
8	59.762	184.7	8	53	1	30	12	48	0
9	58.579	184.8	9	178	2	30	12	68	0
10	57.665	185.1	10	106	1	30	12	88	0
11	56.561	185.6	11	34	1	30	12	88	0
12	55.516	186.0	12	0	0	30	12	88	1
13	54.219	185.7	13	115	2	30	12	68	0
14	53.608	186.1	14	-66	2	30	12	68	0
15	52.729	186.8	15	26	2	30	12	68	1
16	51.611	186.1	16	-13	3	30	12	48	12
17	50.712	186.3	17	75	2	30	12	48	0
18	49.891	186.7	18	-63	2	30	12	48	0
19	48.841	187.4	19	142	2	30	12	48	12
20	47.842	187.6	20	66	2	30	12	48	0

FIELD DATA TABLE

Shot number 25 Shot point 37 Team 5
Shot time: 175:10:36: 0.016

Loc	Dist(km)	Azim	Unit	Chron	Chan	C1	C2	C3	Tape grade
1	71.402	3.2	81	33	1	30	12	48	0
2	72.426	3.2	82	-12	1	30	12	48	0
3	73.731	2.9	83	39	1	30	12	48	1
4	75.094	2.0	84	-25	1	30	12	48	0
5	76.579	1.0	85	41	1	30	12	48	0
6	77.654	1.1	86	-11	1	30	12	48	1
7	78.787	1.8	87	4	1	30	12	68	0
8	80.760	3.0	88	11	2	30	12	88	0
9	81.741	3.1	89	--	0	30	12	88	0
10	82.713	3.1	90	0	1	30	12	68	0
11	83.583	3.4	91	8	1	30	12	68	0
12	84.618	3.4	92	0	0	30	12	68	0
13	86.712	3.1	93	6	1	30	12	68	0
14	87.731	2.4	94	12	1	30	12	48	0
15	88.762	1.8	95	0	1	30	12	48	0
16	89.775	1.9	96	6	1	30	12	48	0
17	90.704	1.9	97	2	1	30	12	48	0
18	91.671	2.3	98	22	1	30	12	48	0
19	92.578	2.8	99	11	1	30	12	48	0
20			100	7	1	30	12	48	1

FIELD DATA TABLE

Shot number 26 Shot point 19 Team 2
Shot time: 176: 6:30: 0.009

Loc	Dist(km)	Azim	Unit	Chron	Chan	C1	C2	C3	Tape grade
1	46.847	186.8	21	-56	2	30	12	48	0
2	46.148	189.6	22	29	2	30	12	48	0
3	44.953	188.4	23	56	1	30	12	48	0
4	43.860	187.9	24	4	1	30	12	48	0
5	42.636	187.8	25	134	1	30	12	48	0
6	41.442	188.0	26	37	1	30	12	48	0
7	39.527	188.4	27	25	1	30	12	48	0
8	40.726	188.1	28	-173	1	30	12	48	0
9	38.502	186.9	29	34	2	30	12	48	0
10	37.210	184.9	30	15	1	30	12	48	0
11	36.226	183.0	31	3	3	30	12	48	0
12	35.700	182.3	32	93	1	30	12	48	0
13	34.454	181.3	33	198	1	30	12	48	0
14	33.499	179.9	34	36	1	30	12	48	0
15	31.667	178.3	35	-78	1	30	12	48	0
16	30.622	181.1	36	20	1	30	12	48	0
17	30.402	183.7	37	22	1	30	12	48	0
18	28.409	182.2	38	5	2	30	12	68	0
19	26.364	181.6	39	-3	1	30	12	68	0
20	26.294	181.1	40	--	--	30	12	68	1

FIELD DATA TABLE

Shot number 25 Shot point 37 Team 6
Shot time: 175:10:36: 0.016

Loc	Dist(km)	Azim	Unit	Chron	Chan	C1	C2	C3	Tape grade
1	93.781	3.1	101	10	2	30	12	48	0
2	94.902	3.8	102	2	1	30	12	48	0
3	95.727	4.4	103	0	2	30	12	48	0
4	96.757	5.0	104	-2	30	12	48	12	0
5	97.669	5.7	105	15	1	30	12	48	0
6	98.427	6.0	106	0	1	30	12	48	0
7	99.771	6.6	107	19	1	30	12	48	0
8	100.810	7.2	108	1	2	30	12	48	0
9	101.764	7.5	109	4	2	30	12	48	0
10	102.685	7.7	110	11	1	30	12	48	0
11	103.680	7.5	111	30	1	30	12	48	0
12	104.610	7.1	112	19	2	30	12	48	0
13	106.897	6.0	113	-7	1	30	12	48	0
14	107.566	5.2	114	1	1	30	12	48	0
15	108.395	4.7	115	4	1	30	12	48	0
16	109.131	4.3	116	6	1	30	12	48	0
17	109.881	4.0	117	19	1	30	12	48	0
18	111.344	3.6	118	21	1	30	12	48	0
19	194.588	358.9	119	0	0	30	12	48	29
20	157.985	1.6	120	-2	1	30	12	48	0

FIELD DATA TABLE

Shot number 26 Shot point 19 Team 3
Shot time: 176: 6:30: 0.009

Loc	Dist(km)	Azim	Unit	Chron	Chan	C1	C2	C3	Tape grade
1	832	24.940	180.9	41	-47	1	30	12 88	0
2	833	23.935	180.1	42	27	1	30	12 68	12
3	742	23.100	179.9	43	18	1	30	12 68	0
4	743	22.514	178.7	44	165	1	30	12 68	0
5	744	22.072	177.4	45	-5	1	30	12 48	0
6	745	20.607	176.5	46	63	1	30	12 48	0
7	746	19.239	174.5	47	2	3	30	12 48	0
8	747	18.488	173.1	48	75	3	30	12 48	0
9	748	17.368	176.0	49	31	1	30	12 48	0
10	749	16.551	173.1	50	-69	3	30	12 48	0
11	750	15.853	177.0	51	106	3	30	12 48	0
12	751	14.575	180.9	52	96	3	30	12 48	0
13	752	13.748	180.9	53	34	3	30	12 48	1
14	753	14.259	188.1	54	-23	3	30	12 48	0
15	754	12.718	182.0	55	112	3	30	12 48	0
16	755	12.708	190.6	56	65	3	30	12 48	0
17	756	12.083	193.8	57	158	2	30	12 48	0
18	757	11.126	194.8	58	33	3	30	12 48	0
19	758	9.621	197.0	59	-5	3	30	12 48	29
20	759	8.722	198.8	60	-17	3	30	12 48	0

FIELD DATA TABLE

Shot number 26 Shot point 19 Team 5
Shot time: 176: 6:30: 0.009

Loc	Dist(km)	Azim	Unit	Chron	Chan	C1	C2	C3	Tape grade
1	779	15.565	354.4	81	33	3	30	12 48	0
2	780	16.576	355.0	82	-12	3	30	12 48	0
3	781	17.526	354.3	83	39	3	30	12 48	1
4	782	19.463	351.5	84	-25	3	30	12 48	0
5	783	21.183	348.7	85	41	3	30	12 48	0
6	784	22.193	349.8	86	-11	1	30	12 48	1
7	785	23.140	352.6	87	4	1	30	12 68	0
8	787	25.059	357.1	88	11	1	30	12 88	0
9				89	--				20
10	788	26.023	357.6	90	0	1	30	12 88	0
11	789	26.987	357.9	91	8	1	30	12 68	0
12	790	27.826	358.8	92	0	0	30	12 68	12
13	791	28.855	359.1	93	6	1	30	12 68	0
14	793	30.986	358.5	94	12	3	30	12 48	0
15	794	32.099	356.7	95	0	1	30	12 48	0
16	795	33.219	355.4	96	6	1	30	12 48	0
17	796	34.220	355.7	97	2	1	30	12 48	0
18	797	35.139	356.0	98	22	1	30	12 48	0
19	798	36.046	357.1	99	11	3	30	12 48	0
20	799	36.886	358.4	100	7	1	30	12 48	1

FIELD DATA TABLE

Shot number 26 Shot point 19 Team 4
Shot time: 176: 6:30: 0.009

Loc	Dist(km)	Azim	Unit	Chron	Chan	C1	C2	C3	Tape grade
1	760	8.347	188.7	61	33	2	30	12 48	0
2	762	7.106	203.5	62	0	3	30	12 48	0
3	761	6.579	193.6	63	18	3	30	12 48	0
4	763	5.286	196.0	64	63	3	30	12 48	0
5	764	4.277	193.6	65	-16	3	30	12 48	0
6	765	3.332	189.1	66	22	3	30	12 68	0
7	766	2.257	172.2	67	98	3	30	12 68	0
8	767	1.470	162.4	68	-8	2	30	12 88	0
9	768	0.114	133.0	69	8	3	30	12 88	1
10	769	0.961	12.6	70	106	3	30	12 88	0
11	770	1.773	331.0	71	77	3	30	12 68	1
12	771	3.437	325.3	72	48	3	30	12 68	0
13	772	4.619	332.7	73	-39	3	30	12 48	0
14	773	5.650	334.2	74	44	3	30	12 48	0
15	774	6.552	340.2	75	46	3	30	12 48	0
16	775	7.415	341.0	76	-8	3	30	12 48	29
17	776	8.237	342.2	77	19	3	30	12 48	0
18	777	9.994	341.7	78	-40	3	30	12 48	0
19	778	13.256	348.7	79	117	3	30	12 48	0
20				80	25				1

FIELD DATA TABLE

Shot number 26 Shot point 19 Team 6
Shot time: 176: 6:30: 0.009

Loc	Dist(km)	Azim	Unit	Chron	Chan	C1	C2	C3	Tape grade
1	800	38.047	359.5	101	28	1	30	12 48	0
2	801	39.109	1.2	102	5	3	30	12 48	0
3	802	39.898	2.6	103	2	1	30	12 48	0
4	803	40.906	4.1	104	-4	1	30	12 48	12
5	804	41.811	5.8	105	42	1	30	12 48	0
6	805	42.573	6.5	106	-2	3	30	12 48	0
7	806	43.933	7.8	107	55	1	30	12 48	0
8	807	45.003	9.1	108	4	1	30	12 48	0
9	808	45.978	9.8	109	12	1	30	12 48	0
10	809	46.910	10.0	110	31	3	30	12 48	0
11	810	47.894	9.6	111	84	3	30	12 48	0
12	811	48.802	8.6	112	55	1	30	12 48	0
13	812	51.061	6.3	113	-18	1	30	12 48	0
14	813	51.733	4.8	114	2	1	30	12 48	0
15	814	52.576	3.8	115	11	1	30	12 48	0
16	815	53.330	2.9	116	19	1	30	12 48	29
17	816	54.098	2.3	117	55	1	30	12 48	0
18	817	55.591	1.5	118	59	1	30	12 48	0
19	835	139.175	356.2	119	2	1	30	12 48	29
20	834	102.247	359.5	120	-4	1	30	12 48	0

FIELD DATA TABLE

Shot number 27 Shot point 36 Team 1
 Shot time: 176:16; 0: 0.335

Loc	Dist(km)	Azim	Unit	Chron	Chan	C1	C2	C3	Tape grade
1	701	48.804	18.3	1	33	3	30	12 48	0
2	702	49.457	16.9	2	63	3	30	12 48	0
3	703	50.209	16.0	3	20	3	30	12 48	0
4	704	50.952	14.7	4	-70	3	30	12 48	0
5	705	51.766	14.4	5	24	3	30	12 48	0
6	706	52.680	14.0	6	8	8	30	12 48	1
7	707	53.608	13.6	7	7	3	30	12 48	0
8	708	54.547	13.3	8	62	1	30	12 48	0
9	710	55.692	13.0	9	191	1	30	12 68	0
10	711	56.553	12.5	10	113	1	30	12 88	0
11	712	57.595	12.0	11	37	1	30	12 88	0
12	713	58.593	11.5	12	0	0	30	12 88	1
13	714	59.908	11.6	13	124	13	30	12 68	12
14	715	60.480	11.2	14	-71	1	30	12 68	0
15	716	61.305	10.5	15	28	30	12 68	12	12
16	717	62.472	11.0	16	-14	3	30	12 48	0
17	718	63.353	10.8	17	80	1	30	12 48	0
18	719	64.146	10.4	18	-68	1	30	12 48	0
19	720	65.157	9.8	19	152	1	30	12 48	0
20	721	66.150	9.6	20	70	1	30	12 48	0

FIELD DATA TABLE

Shot number 27 Shot point 36 Team 3
 Shot time: 176:16; 0: 0.335

Loc	Dist(km)	Azim	Unit	Chron	Chan	C1	C2	C3	Tape grade
1	832	89.149	11.0	41	-50	2	30	12 88	0
2	833	90.197	11.1	42	30	30	12 68	4	4
3	742	91.037	11.1	43	19	2	30	12 68	0
4	743	91.706	11.3	44	177	30	12 68	12	12
5	744	92.252	11.5	45	-5	30	12 48	4	4
6	745	93.754	11.5	46	68	2	30	12 48	0
7	746	95.258	11.7	47	2	1	30	12 48	0
8	747	96.108	11.8	48	81	1	30	12 48	0
9	748	96.917	11.1	49	34	1	30	12 48	0
10	749	97.937	11.4	50	-74	1	30	12 48	0
11	750	98.305	10.7	51	114	2	30	12 48	0
12	751	99.347	9.9	52	103	30	12 48	12	12
13	752	100.161	9.9	53	37	30	12 48	1	1
14	753	99.503	8.9	54	-25	1	30	12 48	0
15	754	101.141	9.6	55	120	1	30	12 48	0
16	755	101.055	8.5	56	70	1	30	12 48	0
17	756	101.723	8.2	57	170	1	30	12 48	12
18	757	102.694	8.1	58	36	1	30	12 48	0
19	758	104.234	8.0	59	-5	1	30	12 48	0
20	759	105.168	7.9	60	-19	2	30	12 48	0

FIELD DATA TABLE

Shot number 27 Shot point 36 Team 2
 Shot time: 176:16; 0: 0.335

Loc	Dist(km)	Azim	Unit	Chron	Chan	C1	C2	C3	Tape grade
1	722	67.178	10.2	21	-61	1	30	12 48	0
2	723	67.830	8.2	22	31	1	30	12 48	0
3	724	69.021	9.0	23	60	1	30	12 48	0
4	725	70.122	9.3	24	4	30	12 48	4	4
5	726	71.349	9.4	25	143	30	12 48	29	29
6	727	72.537	9.2	26	40	30	12 48	4	4
7	729	74.447	9.0	27	26	30	12 48	4	4
8	728	73.253	9.2	28	-185	30	12 48	4	4
9	730	75.504	9.7	29	36	30	12 48	4	4
10	731	76.893	10.6	30	16	1	30	12 48	0
11	732	78.027	11.5	31	4	30	12 48	4	4
12	733	78.611	11.7	32	100	1	30	12 48	0
13	734	79.955	12.0	33	212	1	30	12 48	0
14	735	80.879	12.5	34	39	1	30	12 48	0
15	736	82.878	12.8	35	-84	1	30	12 48	0
16	737	83.556	11.6	36	21	30	12 48	4	4
17	738	83.563	10.6	37	23	2	30	12 48	0
18	739	85.634	11.0	38	6	2	30	12 68	0
19	740	87.108	11.0	39	-3	1	30	12 68	0
20	741	87.807	11.1	40	--	--	30	12 68	1

FIELD DATA TABLE

Shot number 27 Shot point 36 Team 4
 Shot time: 176:16; 0: 0.335

Loc	Dist(km)	Azim	Unit	Chron	Chan	C1	C2	C3	Tape grade
1	760	105.400	8.8	61	35	30	12 48	4	4
2	762	106.884	7.8	62	0	2	30	12 48	0
3	761	107.188	8.5	63	20	2	30	12 48	0
4	763	108.498	8.4	64	68	1	30	12 48	0
5	764	109.477	8.6	65	-17	30	12 48	4	4
6	765	110.404	8.8	66	24	1	30	12 68	0
7	766	111.574	9.1	67	105	2	30	12 68	29
8	767	112.419	9.1	68	-9	30	12 88	0	0
9	768	113.665	8.8	69	8	30	12 88	1	1
10	769	114.686	8.8	70	114	30	12 88	4	4
11	770	115.131	8.2	71	83	30	12 68	1	1
12	771	116.238	7.6	72	52	2	30	12 68	0
13	772	117.481	7.4	73	-42	2	30	12 48	0
14	773	118.412	7.2	74	47	2	30	12 48	0
15	774	119.504	7.2	75	50	3	30	12 48	0
16	775	120.319	7.1	76	-9	30	12 48	12	12
17	776	121.127	7.0	77	20	2	30	12 48	0
18	777	122.688	6.6	78	-43	30	12 48	4	4
19	778	126.225	6.7	79	125	2	30	12 48	0
20				80					1

FIELD DATA TABLE

NTS EVENT
 Shot number 28 Shot point 99 Team 1
 Shot time: 163:15:15: 0.082

Loc	Dist(km)	Azim	Unit	Chron	Chan	C1	C2	C3	Tape grade
1	636	3409.051	1	9		30	12	48	0
2	638	3407.876	2	7	2	30	12	48	0
3	104	3405.993	3	5	2	30	12	48	0
4	106	3404.641	4	-11	2	30	12	48	0
5	108	3403.510	5	6	2	30	12	48	0
6	110	3401.861	6	3		30	12	48	0
7	112	3399.544	7	0		30	12	48	0
8	636	3409.051	8	---		30	12	48	0
9	638	3407.876	9	---		30	12	48	0
10	104	3405.993	10	---		30	12	48	0
11	106	3404.641	11	---		30	12	48	0
12	108	3403.510	12	---		30	12	48	0
13	110	3401.861	13	---		30	12	48	0
14	112	3399.544	14	---		30	12	48	0
15	638	3407.876	15	---		30	12	48	0
16	104	3405.993	16	---		30	12	48	0
17	106	3404.641	17	---		30	12	48	0
18	108	3403.510	18	---		30	12	48	0
19	110	3401.861	19	---		30	12	48	0
20	112	3399.544	20	---		30	12	48	0

FIELD DATA TABLE

Shot number 27 Shot point 36 Team 5
 Shot time: 176:16: 0: 0.335

Loc	Dist(km)	Azim	Unit	Chron	Chan	C1	C2	C3	Tape grade	
1	779	128.829	81	52		30	12	48	1	
2	780	129.849	7.0	-19	2	30	12	48	0	
3	781	131.120	6.8	61		30	12	48	1	
4	782	132.393	6.2	-39	2	30	12	48	0	
5	783	133.766	5.6	65		30	12	48	12	
6	784	134.852	5.7	86	-17	30	12	48	1	
7	785	136.051	6.0	87	6	30	12	68	0	
8	787	138.298	6.6	88	34	2	30	12	88	0
9				89	---				20	
10	788	139.287	6.7	90	-3	2	30	12	88	0
11	789	140.261	6.7	91	26	2	30	12	68	0
12	790	141.151	6.8	92	-2	2	30	12	68	12
13	791	142.188	6.8	93	19		30	12	68	4
14	793	144.247	6.5	94	37	1	30	12	48	0
15	794	145.196	6.1	95	-2	2	30	12	48	0
16	795	146.166	5.7	96	20	1	30	12	48	0
17	796	147.182	5.7	97	5		30	12	48	4
18	797	148.113	5.7	98	67	1	30	12	48	0
19	798	149.117	5.9	99	35	1	30	12	48	0
20	799	150.071	6.2	100	23		30	12	48	1

FIELD DATA TABLE

NTS EVENT
 Shot number 28 Shot point 99 Team 2
 Shot time: 163:15:15: 0.082

Loc	Dist(km)	Azim	Unit	Chron	Chan	C1	C2	C3	Tape grade
1	584	3441.537	21	-7	2	30	12	48	0
2	584	3441.537	22	4		30	12	48	0
3	584	3441.537	23	9		30	12	48	0
4	582	3443.414	24	1	2	30	12	48	0
5	582	3443.414	25	9		30	12	48	0
6	582	3443.414	26	1		30	12	48	0
7	580	3444.188	27	4	2	30	12	48	0
8	580	3444.188	28	---		30	12	48	0
9	580	3444.188	29	5		30	12	48	0
10	578	3445.012	30	3	2	30	12	48	0
11	578	3445.012	31	2		30	12	48	0
12	578	3445.012	32	12		30	12	48	0
13	576	3445.993	33	17	2	30	12	48	0
14	576	3445.993	34	5		30	12	48	0
15	576	3445.993	35	-10		30	12	48	0
16	574	3447.447	36	2	2	30	12	48	0
17	574	3447.447	37	3		30	12	48	0
18	574	3447.447	38	1		30	12	48	0
19	572	3450.039	39	0	2	30	12	48	0/12
20	572	3450.039	40	3		30	12	48	0

FIELD DATA TABLE

Shot number 27 Shot point 36 Team 6
 Shot time: 176:16: 0: 0.335

Loc	Dist(km)	Azim	Unit	Chron	Chan	C1	C2	C3	Tape grade	
1	800	151.309	6.4	101	32	1	30	12	48	0
2	801	152.488	6.8	102	6		30	12	48	12
3	802	153.362	7.2	103	2	2	30	12	48	0
4	803	154.438	7.5	104	-5		30	12	48	29
5	804	155.401	8.0	105	48		30	12	48	4
6	805	156.179	8.1	106	-3	1	30	12	48	0
7	806	157.557	8.5	107	63	2	30	12	48	0
8	807	158.631	8.9	108	5	1	30	12	48	0
9	808	159.601	9.1	109	13	2	30	12	48	0
10	809	160.528	9.1	110	36	1	30	12	48	0
11	810	161.514	9.0	111	97	1	30	12	48	0
12	811	162.421	8.7	112	63		30	12	48	4
13	812	164.640	8.0	113	-21	1	30	12	48	0
14	813	165.256	7.5	114	2	1	30	12	48	0
15	814	166.044	7.2	115	12	1	30	12	48	0
16	815	166.744	6.9	116	22		30	12	48	4
17	816	167.467	6.7	117	63		30	12	48	4
18	817	168.886	6.4	118	68		30	12	48	4
19	835	251.389	1.7	119	2		30	12	48	29
20	834	215.249	4.3	120	-4	2	30	12	48	0

FIELD DATA TABLE

NTS EVENT
 Shot number 28 Shot point 99 Team 5
 Shot time: 163:15:15: 0.082

Loc	Dist(km)	Azim	Unit	Chron	Chan	C1	C2	C3	Tape grade
1	622	3416.351	323.3	81	0	2	30	12 48	0
2	624	3414.559	323.3	82	-3	2	30	12 48	0
3	626	3412.591	323.3	83	10	2	30	12 48	0
4	628	3411.511	323.3	84	-4	2	30	12 48	0
5	630	3411.538	323.2	85	7	2	30	12 48	0
6	632	3411.443	323.1	86	-2	2	30	12 48	0
7	634	3410.308	323.1	87	1	2	30	12 48	0
8	622	3416.351	323.3	88	8	0	30	12 48	0
9	624	3414.559	323.3	89	0	4	30	12 48	0
10	626	3412.591	323.3	90	4	4	30	12 48	0
11	628	3411.511	323.3	91	5	5	30	12 48	0
12	630	3411.538	323.2	92	0	0	30	12 48	0
13	632	3411.443	323.1	93	5	5	30	12 48	0
14	634	3410.308	323.1	94	9	9	30	12 48	0
15	622	3416.351	323.3	95	1	1	30	12 48	0
16	624	3414.559	323.3	96	1	1	30	12 48	0
17	626	3412.591	323.3	97	6	6	30	12 48	0
18	628	3411.511	323.3	98	0	0	30	12 48	0
19	630	3411.538	323.2	99	8	8	30	12 48	0
20	632	3411.443	323.1	100	6	6	30	12 48	0

FIELD DATA TABLE

NTS EVENT
 Shot number 28 Shot point 99 Team 3
 Shot time: 163:15:15: 0.082

Loc	Dist(km)	Azim	Unit	Chron	Chan	C1	C2	C3	Tape grade
1	606	3433.250	323.4	41	-7	2	30	12 48	0
2	606	3433.250	323.4	42	4	4	30	12 48	0
3	606	3433.250	323.4	43	2	2	30	12 48	0
4	604	3435.047	323.4	44	16	2	30	12 48	0
5	604	3435.047	323.4	45	1	1	30	12 48	0
6	604	3435.047	323.4	46	10	10	30	12 48	0
7	602	3436.410	323.5	47	1	2	30	12 48	0
8	602	3436.410	323.5	48	10	10	30	12 48	0
9	602	3436.410	323.5	49	5	5	30	12 48	0
10	591	3437.794	323.5	50	-8	2	30	12 48	0
11	591	3437.794	323.5	51	10	10	30	12 48	0
12	591	3437.794	323.5	52	3	3	30	12 48	0
13	588	3438.172	323.6	53	4	2	30	12 48	0
14	588	3438.172	323.6	54	-2	2	30	12 48	0
15	588	3438.172	323.6	55	8	8	30	12 48	0
16	586	3438.965	323.6	56	9	2	30	12 48	0
17	586	3438.965	323.6	57	12	12	30	12 48	0
18	586	3438.965	323.6	58	5	5	30	12 48	0
19	572	3450.039	323.8	59	0	0	30	12 48	0
20	572	3450.039	323.8	60	-2	2	30	12 48	0

FIELD DATA TABLE

NTS EVENT
 Shot number 28 Shot point 99 Team 4
 Shot time: 163:15:15: 0.082

Loc	Dist(km)	Azim	Unit	Chron	Chan	C1	C2	C3	Tape grade
1	636	3409.051	323.1	61	--	--	30	12 48	0
2	634	3410.308	323.1	62	--	--	30	12 48	0
3				63	--	--			
4				64	--	--			
5				65	--	--			
6				66	--	--			
7				67	--	--			
8				68	--	--			
9				69	--	--			
10				70	--	--			
11				71	--	--			
12				72	--	--			
13				73	--	--			
14				74	--	--			
15				75	--	--			
16				76	--	--			
17				77	--	--			
18				78	--	--			
19				79	--	--			
20				80	--	--			

FIELD DATA TABLE

NTS EVENT
 Shot number 28 Shot point 99 Team 6
 Shot time: 163:15:15: 0.082

Loc	Dist(km)	Azim	Unit	Chron	Chan	C1	C2	C3	Tape grade
1	608	3430.596	323.4	101	8	1	30	12 48	0
2	610	3427.363	323.4	102	4	3	30	12 48	0
3	612	3425.459	323.4	103	0	1	30	12 48	0
4	614	3423.885	323.4	104	0	2	30	12 48	0
5	616	3421.332	323.4	105	12	2	30	12 48	0
6	618	3419.359	323.4	106	-13	2	30	12 48	0
7	620	3417.856	323.4	107	16	2	30	12 48	0
8	608	3430.596	323.4	108	1	1	30	12 48	0
9	610	3427.363	323.4	109	4	4	30	12 48	0
10	612	3425.459	323.4	110	10	10	30	12 48	0
11	614	3423.885	323.4	111	23	23	30	12 48	0
12	616	3421.332	323.4	112	10	10	30	12 48	0
13	618	3419.359	323.4	113	-6	6	30	12 48	0
14	620	3417.856	323.4	114	1	1	30	12 48	0
15	608	3430.596	323.4	115	20	20	30	12 48	0
16	610	3427.363	323.4	116	46	46	30	12 48	0
17	614	3423.885	323.4	117	12	12	30	12 48	0
18	616	3421.332	323.4	118	11	11	30	12 48	0
19	618	3419.359	323.4	119	3	3	30	12 48	0
20	620	3417.856	323.4	120	1	1	30	12 48	0

Appendix B

Archive Tape Data Format

Archive data tapes are written in SEG Y standard format (Barry and others, 1975). Recording density is 1600 bpi, phase encoded (PE). In order to accommodate seismic-refraction data, some minor changes have been made to the tape header fields. A complete list of header fields is provided in the card image portion of the reel identification header shown below:

C 1 REEL IDENTIFICATION HEADER BYTES:
C 2 3217 -3218 sampling interval (microsecs).
C 3 3221 -3222 number of samples per trace.
C 4 3225 -3226 data sample format code.
C 5 3255 -3256 measurement system (1 = meters; 2 = feet).
C 6
C 7
C 8 TRACE IDENTIFICATION HEADER BYTES:
C 9 1 - 4 trace sequence number within reel.
C10 5 - 8 trace sequence number within reel.
C11 9 - 12 station location number.
C12 29 - 30 trace ID code (1 = seismic data).
C13 37 - 40 shotpoint-receiver distance (M).
C14 41 - 44 station elevation (M).
C15 45 - 48 shotpoint elevation (M).
C16 49 - 52 source depth (M).
C17 69 - 70 scalar to be applied to all elevations.
C18 71 - 72 scalar to be applies to all coordinates.
C19 73 - 76 shotpoint coordinate - X.
C20 77 - 80 shotpoint coordinate - Y.
C21 81 - 84 receiver coordinate - X.
C22 85 - 88 receiver coordinate - Y.
C23 89 - 90 coordinate units (1 = meters; 2 = seconds of arc).
C24 115 - 116 number of samples in this trace.
C25 117 - 118 sample interval in microseconds for this trace.
C26 121 - 122 instrument attenuation in db.
C27 157 - 158 shot time - year.
C28 159 - 160 shot time - day of year.
C29 161 - 162 shot time - hour of day (24 hour clock).
C30 163 - 164 shot time - minute of hour.
C31 165 - 166 shot time - second of minute.
C32 167 - 168 time basis code (2 = GMT).
C33 181 - 182 shot time - milliseconds.
C34 183 - 184 shotpoint location number.
C35 185 - 186 recording instrument unit number.
C36 191 - 192 distance weighting exponent (hundredths).
C37 193 - 194 shot sequence number (shot number).
C38 195 - 196 shot size (kg).

C39 197 - 200 shot point - station azimuth (second of arc).
C40 201 - 204 time of first point minus shot time (msec).

The data point format is "32 bit floating point", and the appropriate bytes (3225-3226) of the binary reel id header contain a value of 1. The trace amplitudes have not been adjusted for instrument gain, but the gain correction factor can be estimated from the instrument attenuation value (att) specified in bytes 121-122. To correct for gain, the data should be demeaned and then multiplied by:

$$\frac{(\text{att}/20)}{10}$$

The measurement system (bytes 3255-3256 of the binary reel header) is set to 1, meters.

Shot point and receiver coordinates are in seconds of arc (byte field 89-90). The coordinate scalar multiplier (bytes 71-72) is set to -100, so the coordinates (bytes 73-88) are in hundredths of a second of arc.

Bytes 157-166 and bytes 181-182 refer to the shot detonation time. The time of the first data sample is found by adding the shot detonation time to the time specified in bytes 201-204.

Since there is no weighting of amplitudes with distance for archive tapes, the distance weighting exponent (bytes 191-192) is not used.

Shot sequence number (bytes 193-194) refers to the order in which shots were fired during the field campaign (shot number).