

UNITED STATES DEPARTMENT OF THE INTERIOR
GEOLOGICAL SURVEY

DATA REPORT FOR THE CHEMEHUEVI, VIDAL, AND DUTCH FLAT LINES
PACE, SEISMIC-REFRACTION SURVEY, SOUTHEASTERN CALIFORNIA, AND WESTERN ARIZONA

JEFFERY M. WILSON, AND GARY S. FUIS¹

OPEN-FILE REPORT 87-86

This report is preliminary and has not been reviewed for conformity with U.S. Geological Survey editorial standards and stratigraphic nomenclature. Any use of trade names is for descriptive purposes only and does not imply endorsement by the U.S.G.S.

¹U.S.G.S. Menlo Park, California

1987

Table of Contents

	Page
Introduction	1
Description of Survey	1
Instrumentation and Data Reduction	1
Seismic Recorders	1
Data Reduction	3
Archive Tape.....	4
Acknowledgements	4
References Cited.....	4
Appendix A: Field Data Sheets and Tape Grade Scale	28
Appendix B: Archive Tape Data Format	74

Figures

1. Geologic Map Showing Shotpoint and Recorder Locations	2
2. Record Sections of Shots 1 and 2 - Chemehuevi Line.....	5
3. Record Sections of Shots 3 and 4 - Chemehuevi Line.....	6
4. Record Sections of Shots 5 and 6 - Chemehuevi Line.....	7
5. Record Sections of Shots 7 and 8 - Chemehuevi Line.....	8
6. Record Sections of Shots 9 and 10 - Chemehuevi Line.....	9
7. Record Sections of Shots 11 and 12 - Vidal Line.....	10
8. Record Sections of Shots 13 and 14 - Vidal Line.....	11
9. Record Sections of Shots 15 and 16 - Vidal Line.....	12
10. Record Sections of Shots 17 and 18 - Vidal Line.....	13
11. Record Sections of Shots 19 and 20 - Vidal Line.....	14
12. Record Sections of Shots 21 and 22-Vidal and Dutch Flat Line....	15
13. Record Sections of Shots 23 and 24 - Dutch Flat Line.....	16
14. Record Sections of Shots 25 and 26 - Dutch Flat Line.....	17
15. Record Sections of Shots 27 and 28 - Dutch Flat Line.....	18
16. Record Sections of Shots 29 and 30 - Dutch Flat Line.....	19
17. Schematic Diagram of Seismic Recorders	20
18. System Response Curve for Seismic Recorders	21

Tables

1. Shot Locations and Times	22
Chemehuevi Deployment.....	22
Vidal Deployment.....	23
Dutch Flat Deployment.....	24
2. Seismic Recorder Locations	25
Chemehuevi Deployment.....	25
Vidal Deployment.....	26
Dutch Flat Deployment.....	27

INTRODUCTION

In November 1985, the U.S. Geological Survey conducted a seismic-refraction survey in southeastern California and western Arizona as part of the Pacific-Arizona Crustal Experiment (PACE), a multi-disciplinary transect extending from the Pacific Ocean to the Colorado plateau. The survey was centered over the Whipple Mountains metamorphic core complex, an area characterized by extreme crustal extension. This report is a compilation of the data obtained during this survey.

Description of the Survey

The survey consisted of two crossing lines, that were laid out in three deployments and labeled (1) Chemehuevi, (2) Vidal, and (3) Dutch Flat. A total of 30 shots ranging in size from 225 to 1800 kg of high explosive were used in 20 cm boreholes 45 to 70 m deep. The explosives (ammonium nitrate containing high-pressure beads) were detonated with detonating cord, boosters and electrical blasting caps.

The Chemehuevi line trends SE-NW, from the Plomosa Mountains, north of Quartzsite Arizona, to the Sacramento Mountains, west of Needles, California. This line consisted of 10 shots, including 2 offset shots. Average seismic recorder location spacing was 1 km except for 13 locations at the SE end where spacing was 2.3 km. Location of shot points and seismic recorder sites are listed in Tables 1 and 2, and plotted on Figure 1.

The Vidal and Dutch Flat lines comprise a profile that trends SW-NE, from the McCoy Mountains, west of Blythe California, to the Hualapai Mountains, south of Kingman, Arizona. Of a total of 20 shots, 11 were fired for the Vidal line and 9 for the Dutch Flat line. Shot points 1,4,7,11,12, and 14 were each shot twice, once for each line, shot points 2,3, and 15 were recorded for the Vidal line only, and the shot points 5,6, and 16 were recorded for the Dutch Flat line only. For the Vidal line average station spacing was 0.5 KM, whereas for the Dutch Flat line the station spacing was approximately 0.6 KM. Location of shot points and seismic recorder sites are listed in Tables 1 and 2, and plotted in Figure 1.

Instrumentation and Data Reduction

Seismic Recorders

Field operations involved the deployment of 120 seismic recorders by six observers, each of whom was responsible for 20 instruments. The seismic recorders (Healy and others, 1982) are portable, weigh approximately 18 kg, are powered by two 6-volt rechargeable batteries and contain 30-minute cassette tapes to record data. Packaged with each seismic recorder is a single vertical-component 2-Hz geophone, which is removed, oriented, and buried when the seismograph is deployed. Each recorder also includes a chronometer, three independent amplifiers with pre-set attenuation settings, a calibrator, a tape deck, and a tape-speed-compensation tone generator (Figure 17). Ten minutes prior to the expected seismic energy arrival time, a pre-programmed microprocessor in the seismic recorder performs a geophone

Figure 1: Geologic Map of Study Area, Compiled from Howard (1986), Jennings (1977), Reynolds (1980), and Wilson (1969).

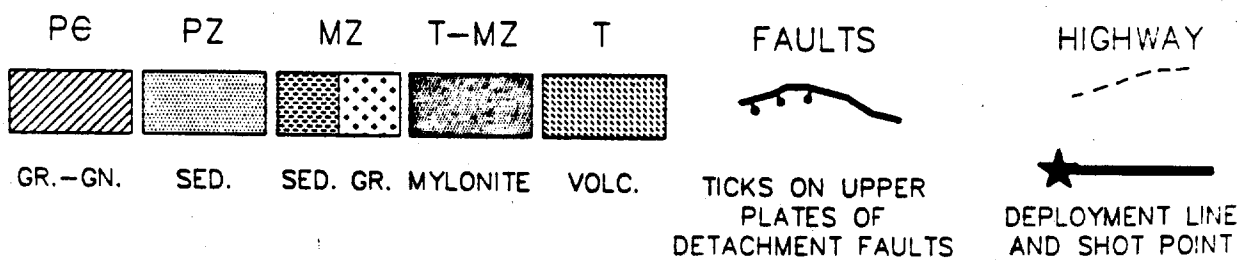
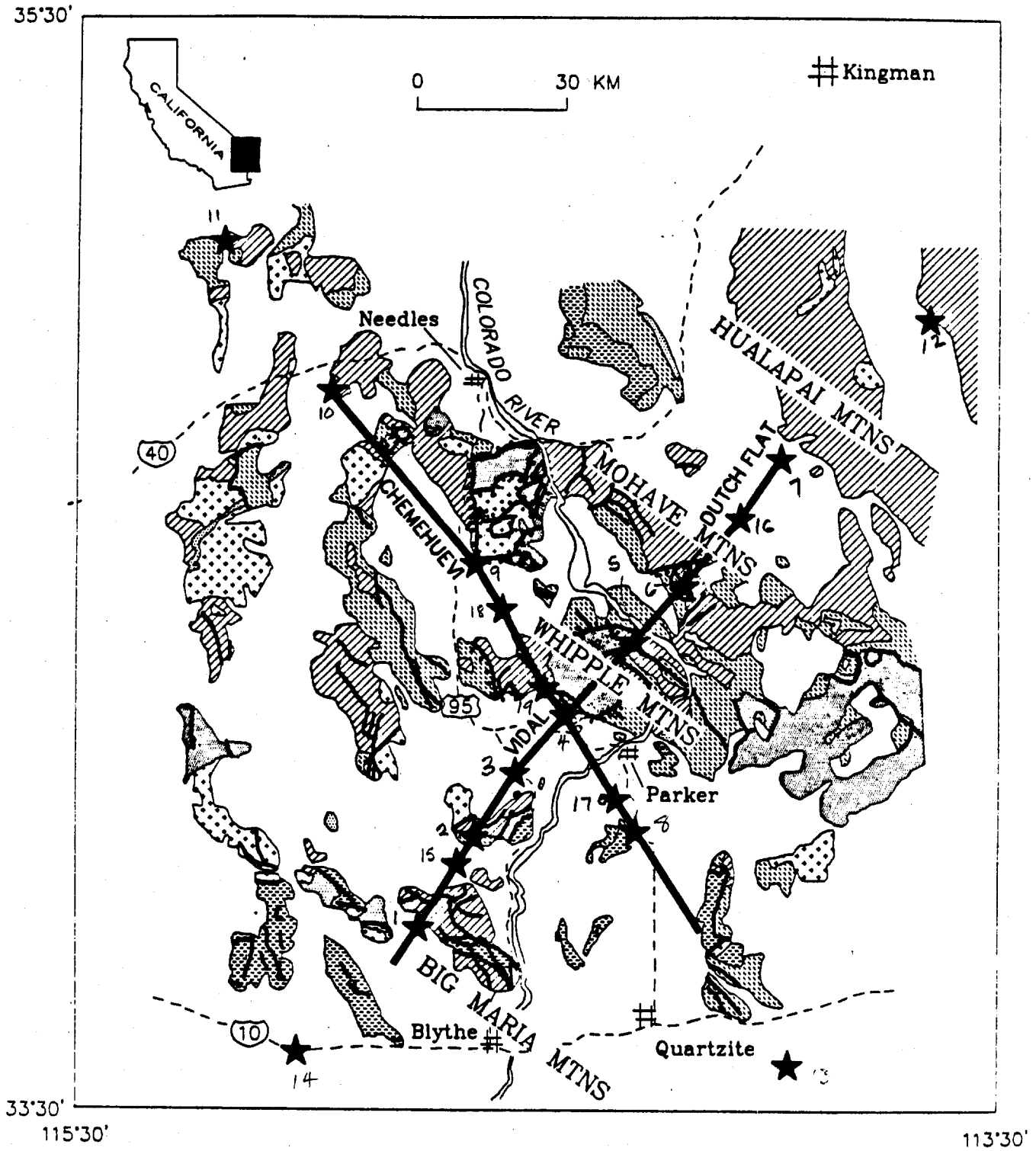

release test, an amplification check, and a calibration sequence consisting of a sine wave with a frequency of 10 Hz and an amplitude of 1, 10, 100, and 1000 mv. The response curve for the system peaks at about 20-hz (Figure 18).

Observers are responsible, before shots are fired, for synchronizing the clock in the seismic recorders, preprogramming the microprocessors with up to 10 distinct recording times, and establishing accurate site locations. For this experiment, recording locations were surveyed prior to deployment of seismic recorders.

After shots have been fired, observers retrieve the seismic recorders, record chronometer drifts, and remove the tapes.

Data Reduction

Shot times are picked from a paper record on which WWVB, the master clock time code, and the detonation pulse are recorded. Shot times are generally accurate to ± 2 milliseconds. Recorder locations and elevations were determined with an estimated accuracy of ± 25 meters using 1:24,000 topographic maps, color infrared aerial photos, and 1:63,360 orthophoto quadrangle maps.

Information pertaining to the performance of the seismic recorders is summarized in the Field Data Tables (Appendix A). After checking for errors in time and site locations, the seismic signals from the cassette tapes were digitized for a total of 20 seconds at a rate of 200 samples/second. Digitization begins at time = shot time - 2.0 sec. + distance/6.0 km/s. For offset shotpoints, digitization begins at time = shot time - 4.0 sec. + distance/6.0 km/s.

The record sections (Figures 2 through 16) are plotted with maximum trace amplitudes normalized to a common value and a reducing velocity of 6.0 km/s.

Archive Tape

Data included in this report are available on SEGY-format tapes recorded at 1600 BPI (Appendix B) from the following:

National Geophysical Data Center
NOAA/EGCI
325 Broadway
Boulder, CO 80303
Telephone: (303) 497-6123

Acknowledgements

The authors wish to express their appreciation to R. Colburn, E. Criley, L. Dietz, R. Kaderabek, E. Kjos, the Late D. Knapp, W. Kohler, J. McCarthy, P. Meador, W. Mooney, J. Murphy, D. Reneau, A. Walter, and D. Whitman for their assistance in field work and data processing.

References cited

- Barry, K.M., Cravers, D. A., and Kneale, C. W. (1975). Recommended standards for digital tape formats, *Geophysics* 40, 344-352.
- Healy, J. H., Mooney, W. D., Blank, H. R., Gettings, M. E., Kohler, W. M., Lamson, R. J., and Leone, L. E., 1982, Saudi Arabian Seismic Deep-refraction Profile: Final Project Report: U.S. Geological Survey Open-File Report USGS-OF-02-37, 429 pp.
- Howard, K. A., 1986, Geologic Map of the Whipple, Turtle, and Old Woman Mountains, southeastern California, written communication.
- Jennings, C. W. (Compiler), 1977, Geologic Map of California: California Division of Mines and Geology, Geologic Data Map No. 2, scale 1:750,000.
- Reynolds, S. J. (Compiler), 1980, Geologic Framework of West-Central Arizona: Arizona Geological Society Digest, Volume XI, approximate scale 1:600,000.
- Wilson, E. D., Moore, R. T., and Cooper, J. R., 1969, Geologic Map of Arizona: U.S. Geological Survey Map, scale 1:500,000

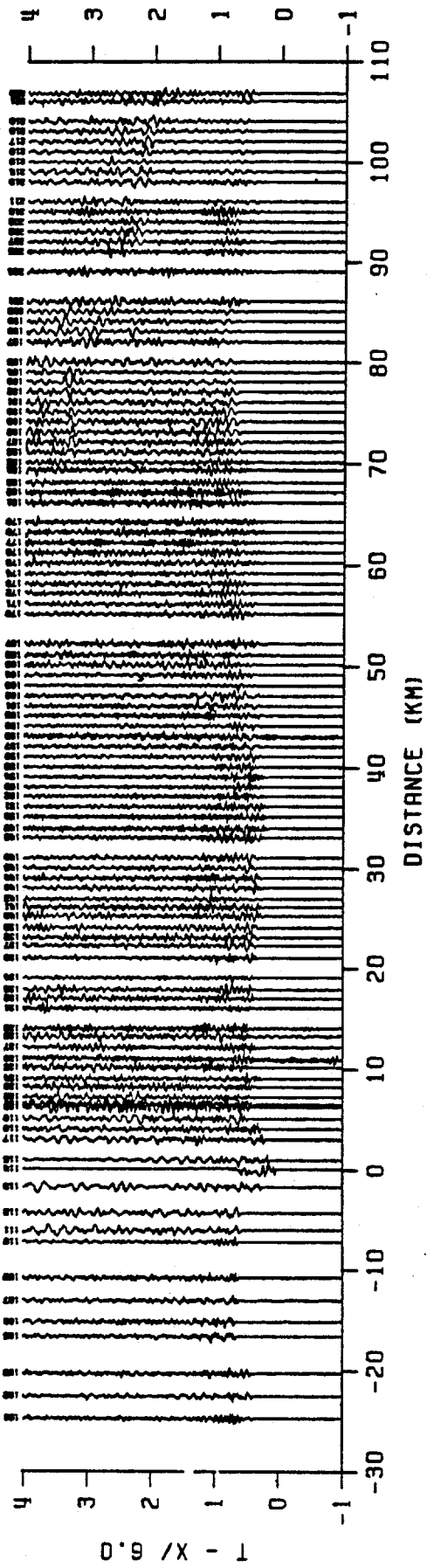

Shot 1, Shotpoint 8

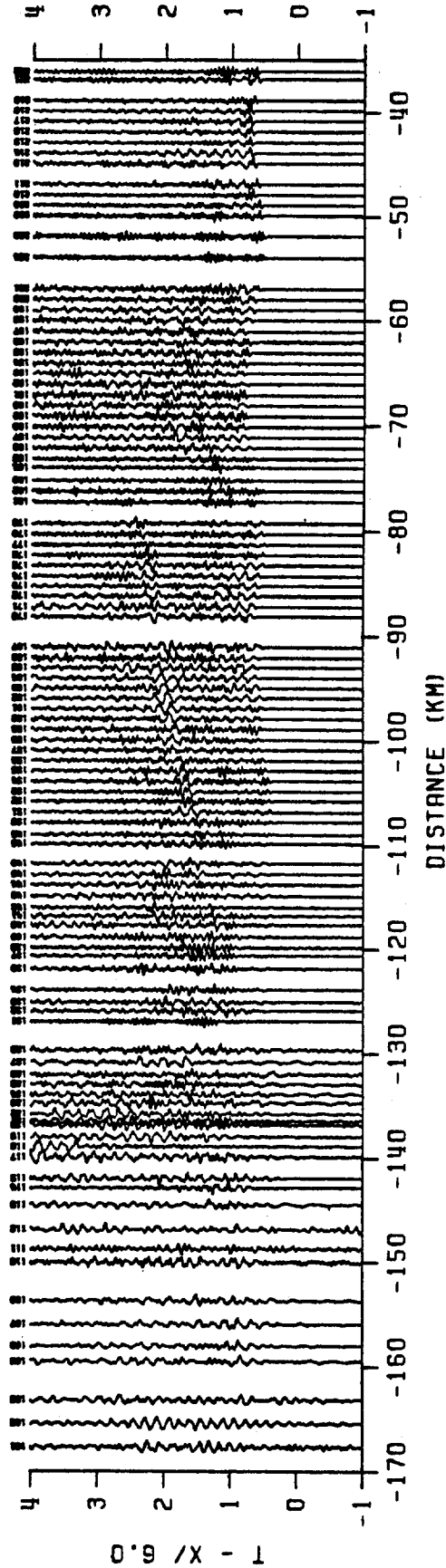

Shot 2, Shotpoint 11 (Offset)

Figure 2: Record Sections From the Chemehuevi Line

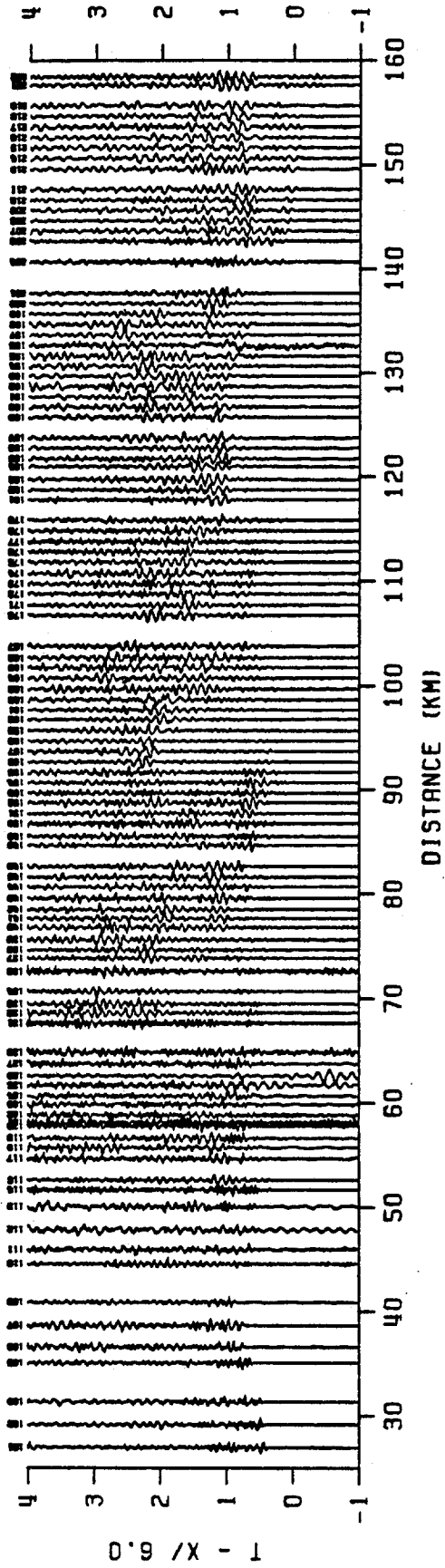

Shot 3, Shotpoint 13 (Offset)

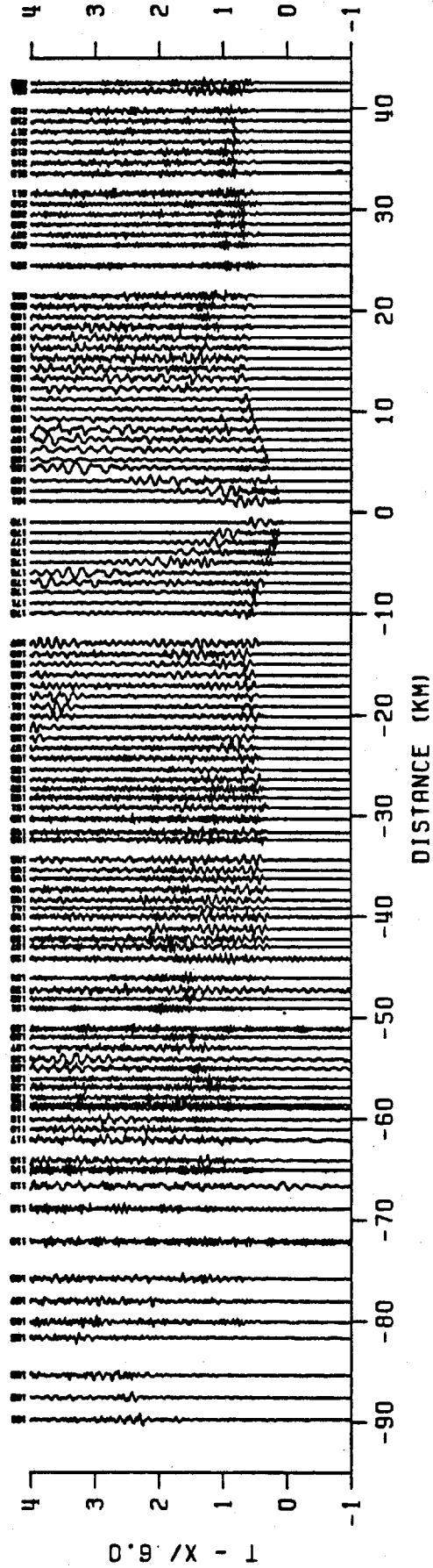

Shot 4, Shotpoint 9

Figure 3: Record Sections From the Chemehuevi Line

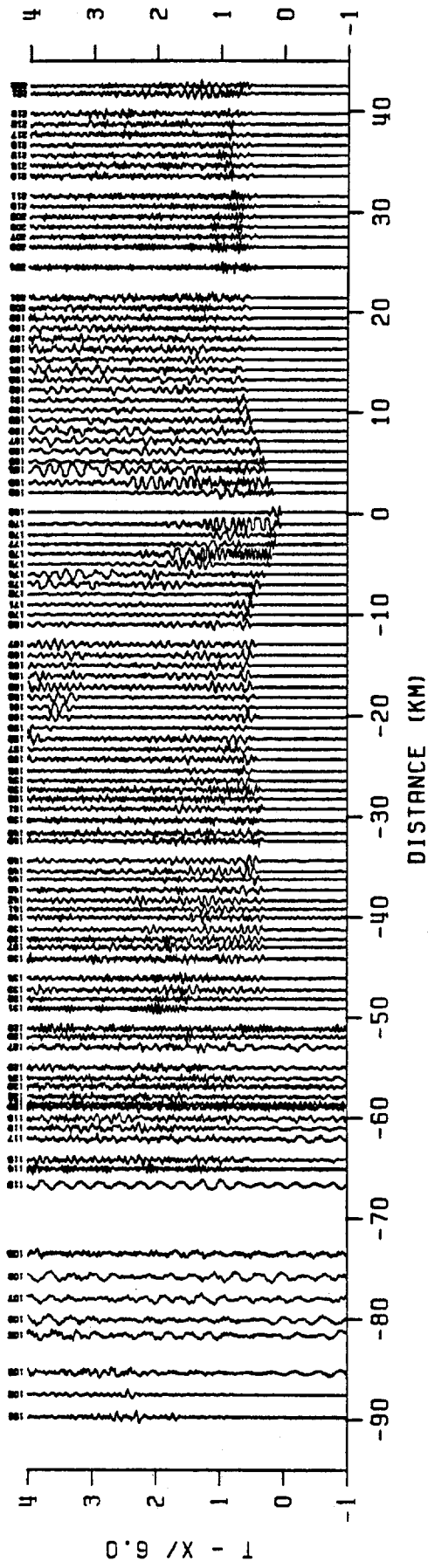

Shot 5, Shotpoint 9

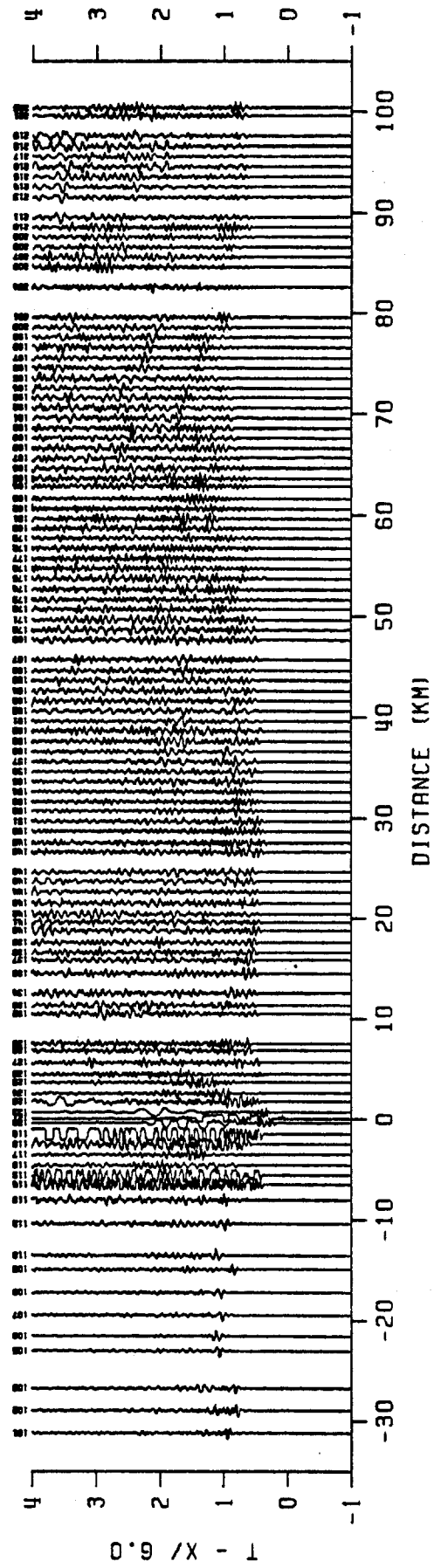

Shot 6, Shotpoint 17

Figure 4: Record Sections From the Chemehuevi Line

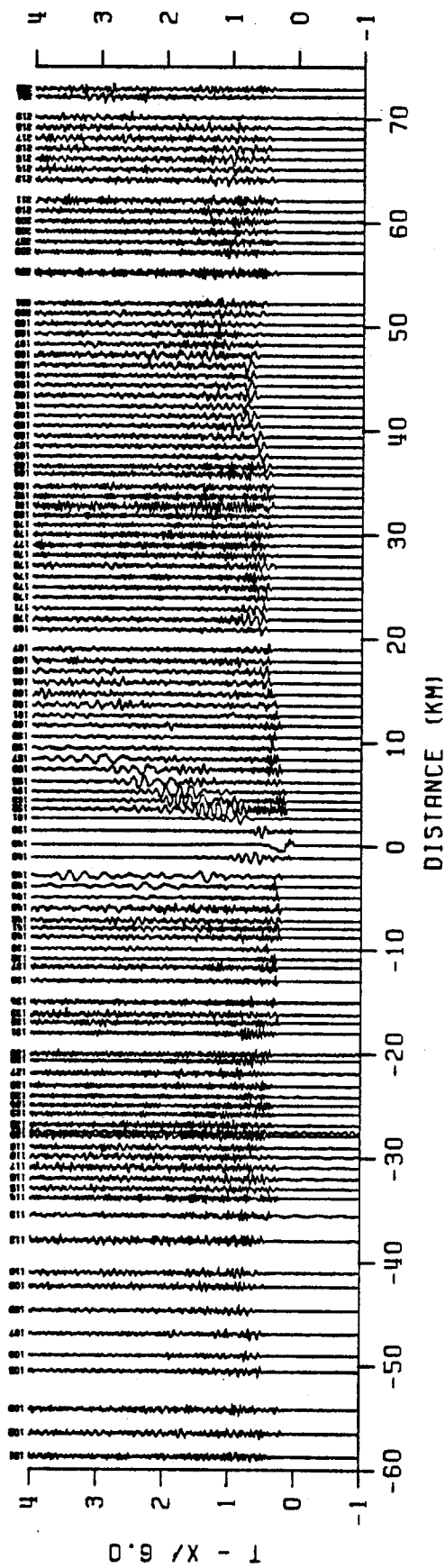
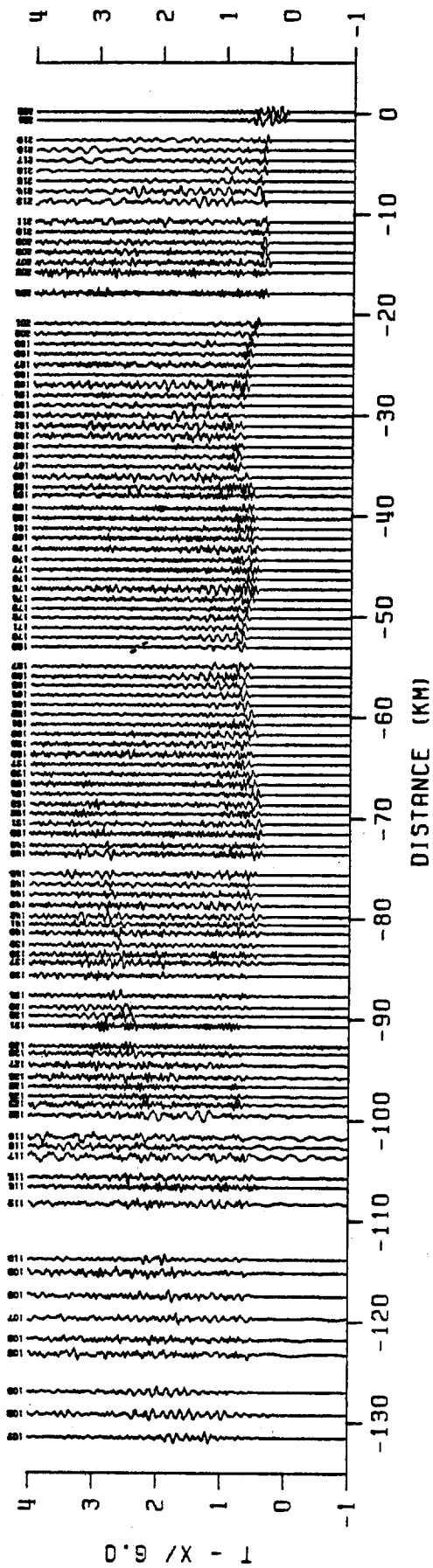
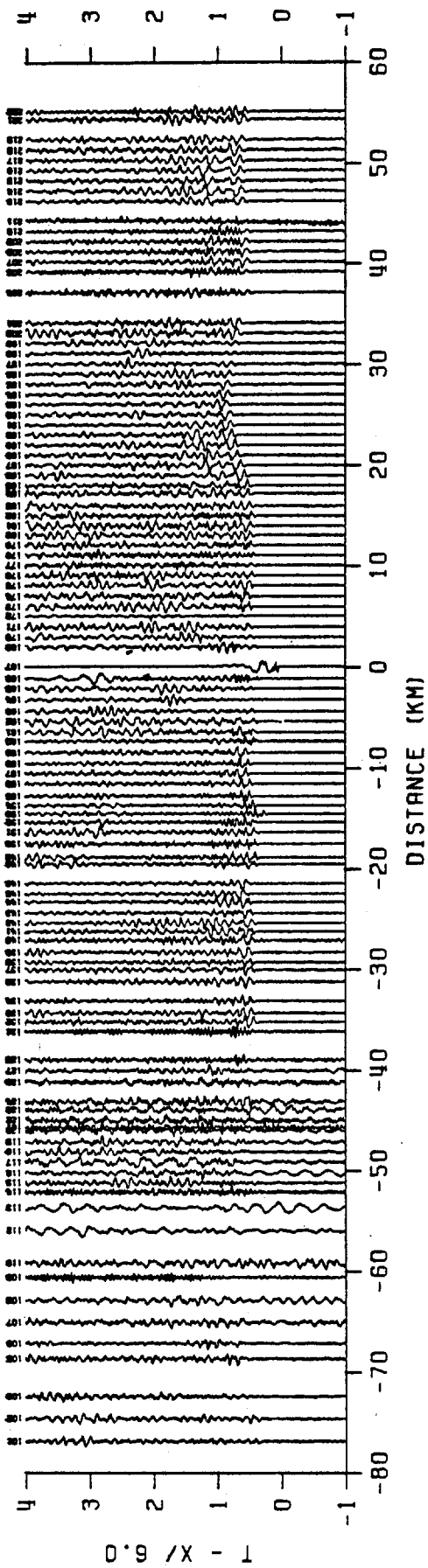
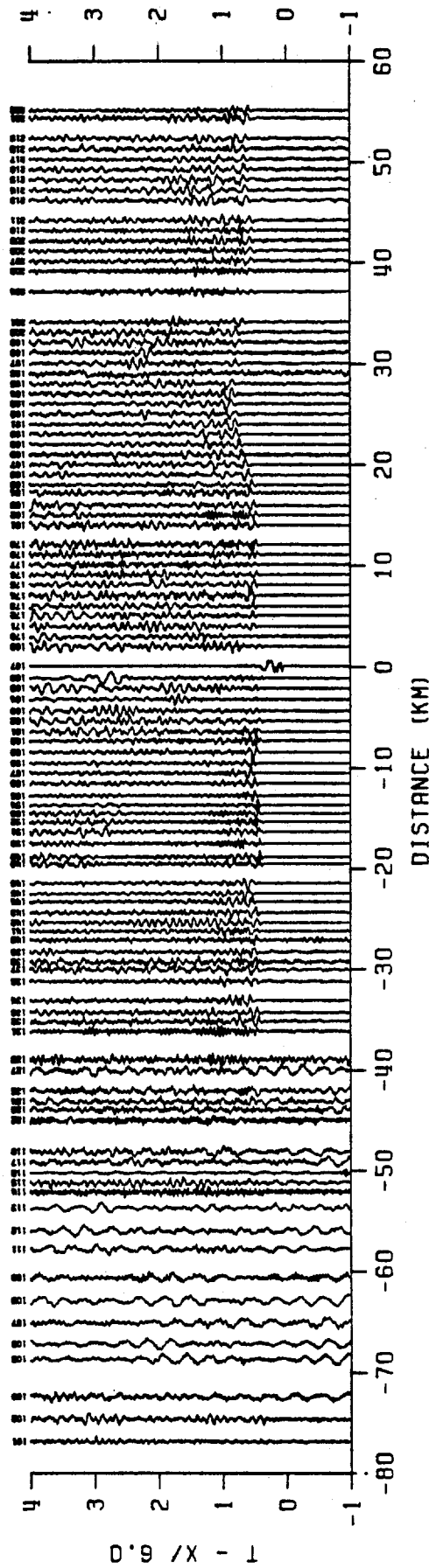

Figure 5: Record Sections From the Chemehuevi Line



Shot 9, Shotpoint 18



Shot 10, Shotpoint 18

Figure 6: Record Sections From the Chemehuevi Line

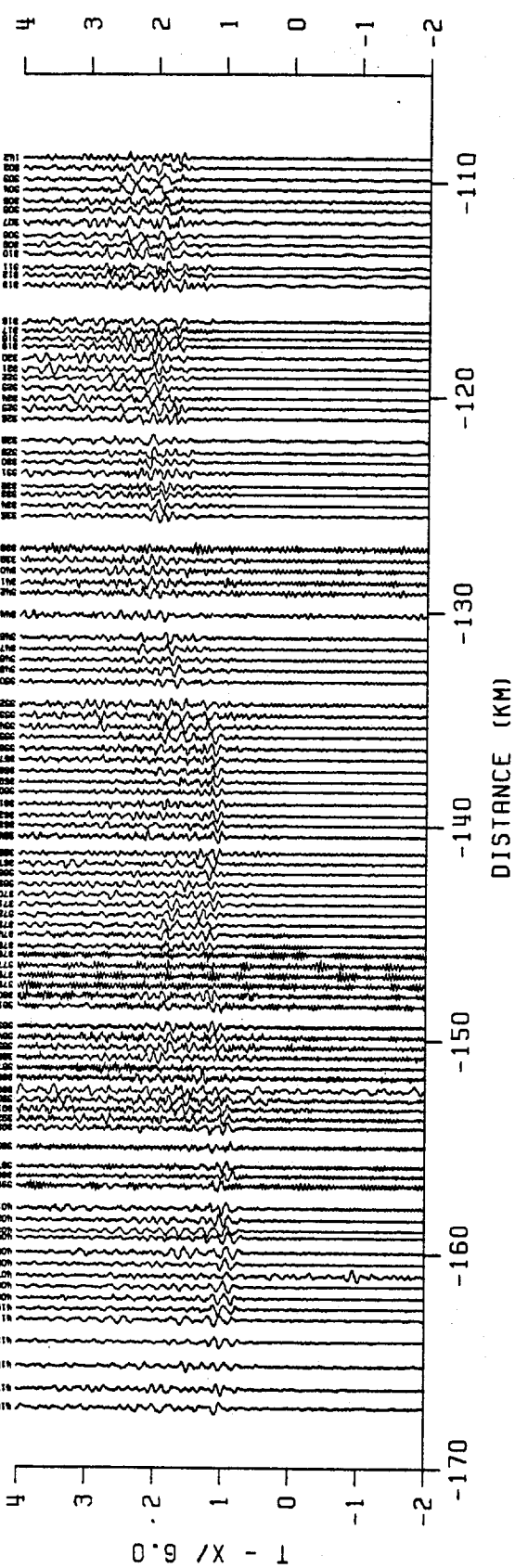

Shot 11, Shotpoint 12 (Offset)

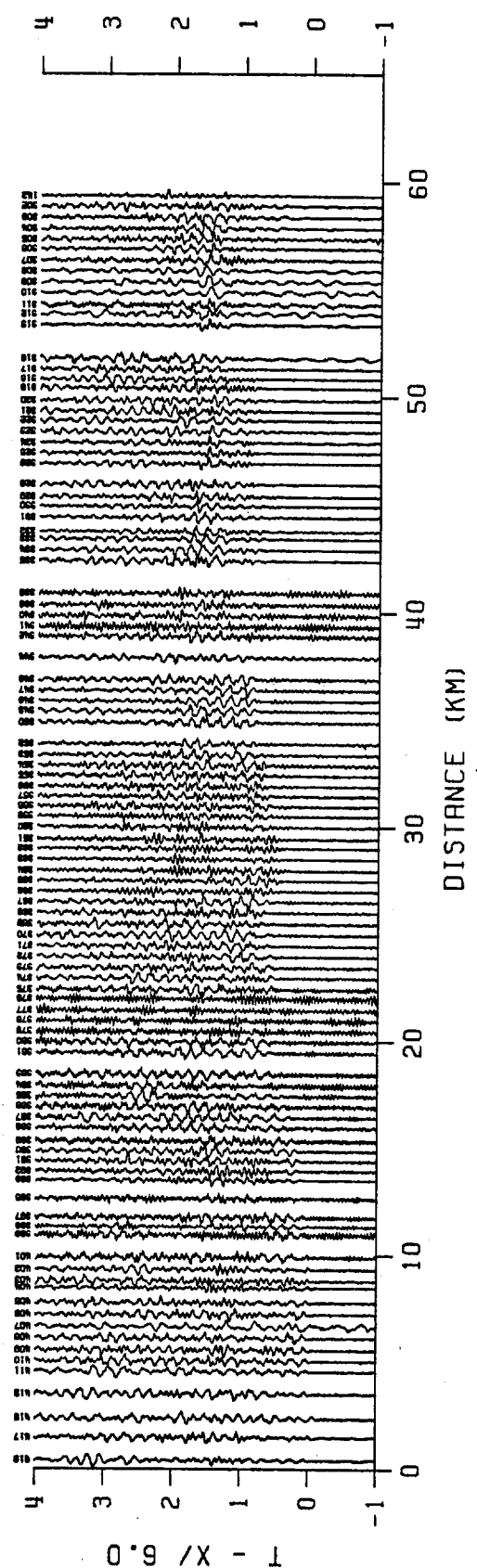

Shot 12, Shotpoint 11 (Fan)

Figure 7: Record Sections From the Vidal Line

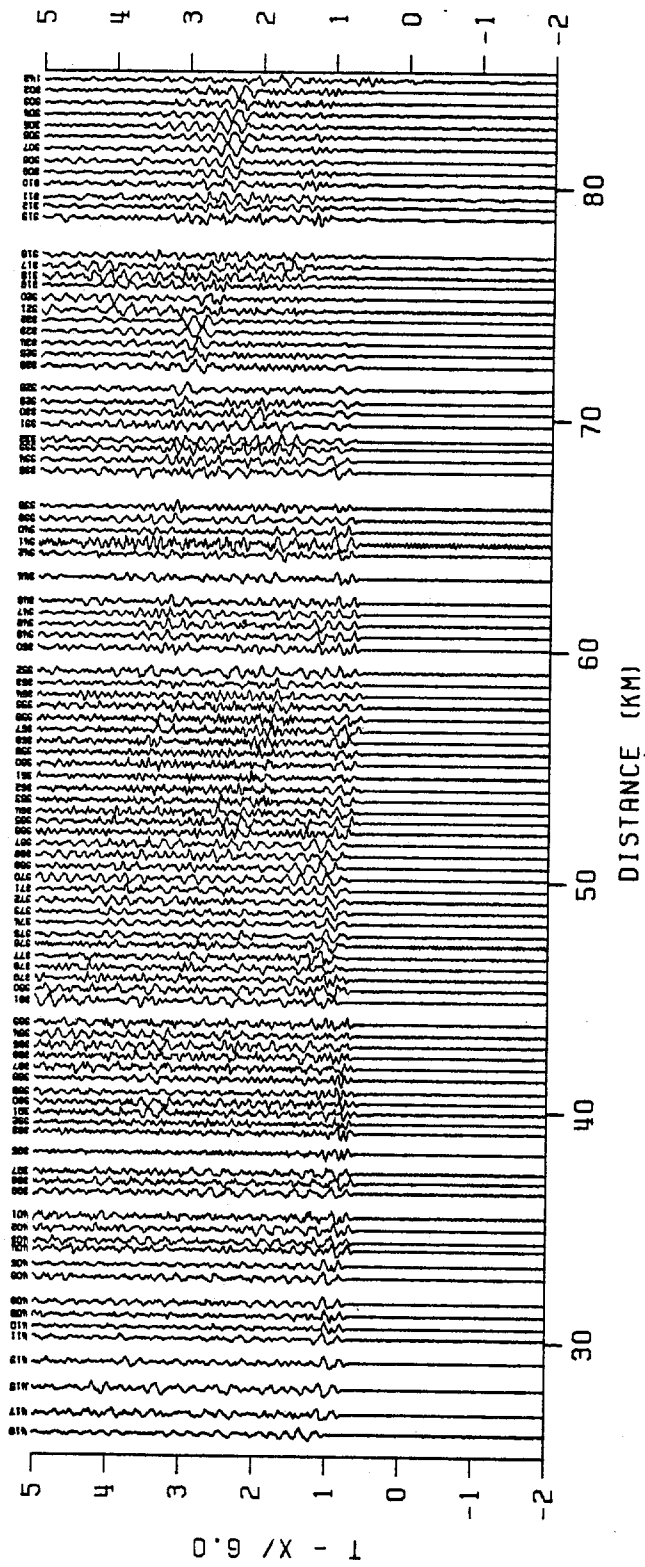

Shot 13, Shotpoint 14 (Offset)

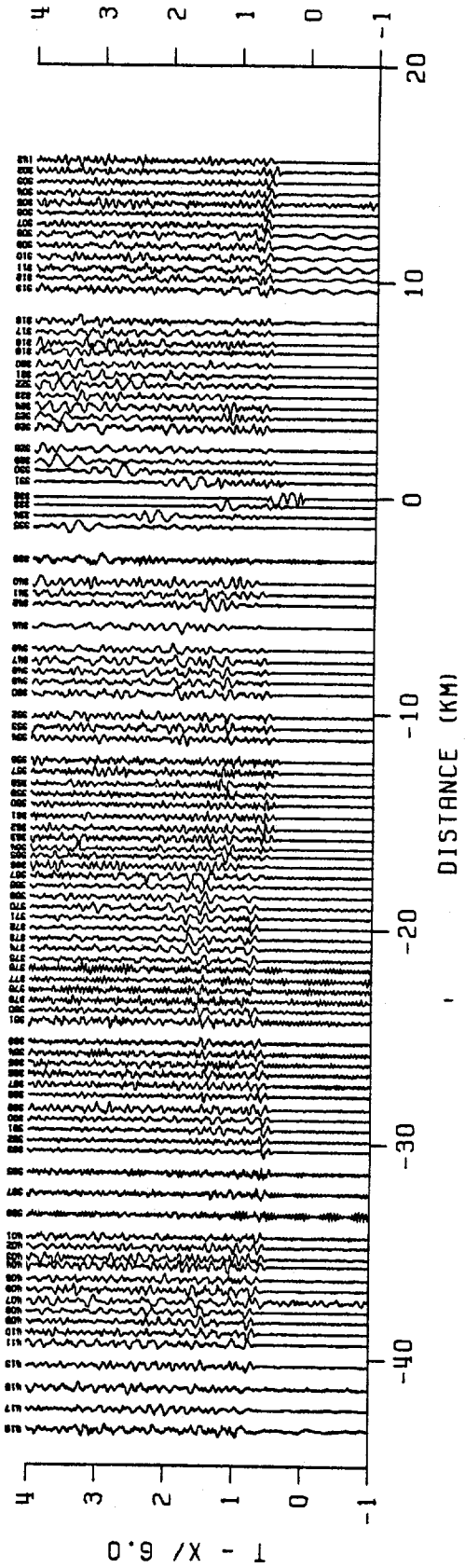

Shot 14, Shotpoint 3

Figure 8: Record Sections From the Vidal Line

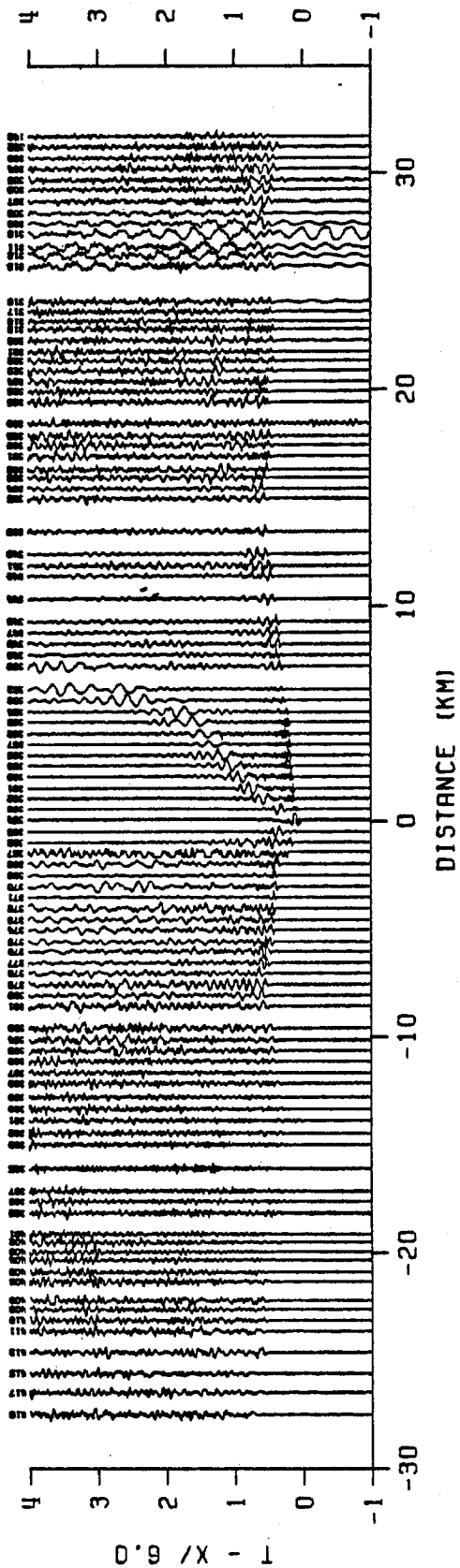

Shot 15, Shotpoint 2

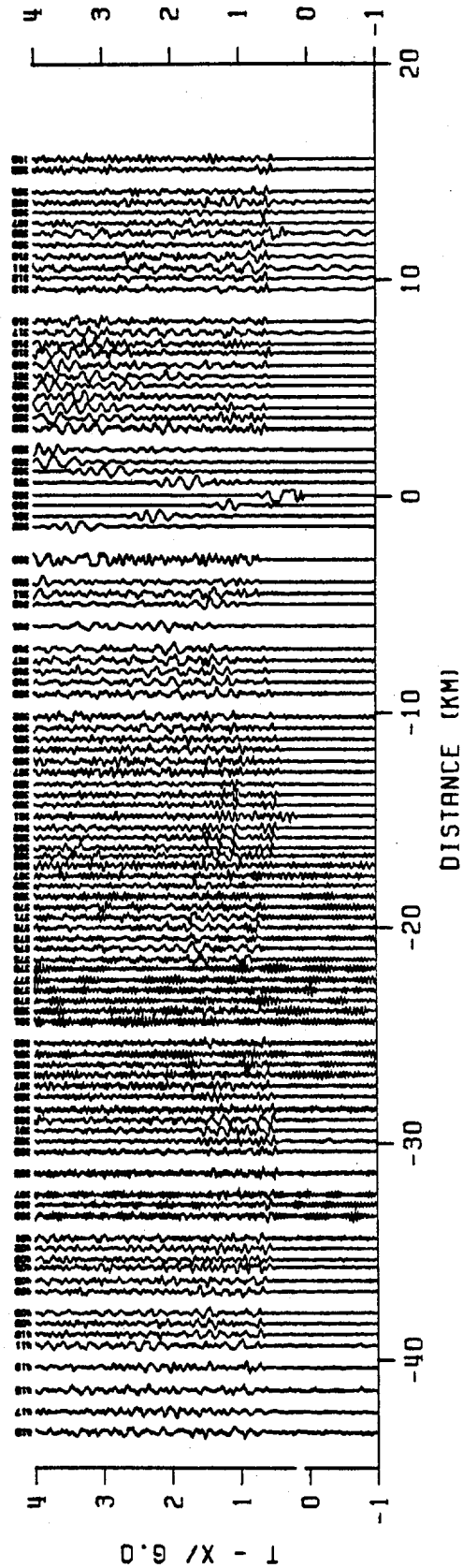

Shot 16, Shotpoint 3

Figure 9: Record Sections From the Vidal Line

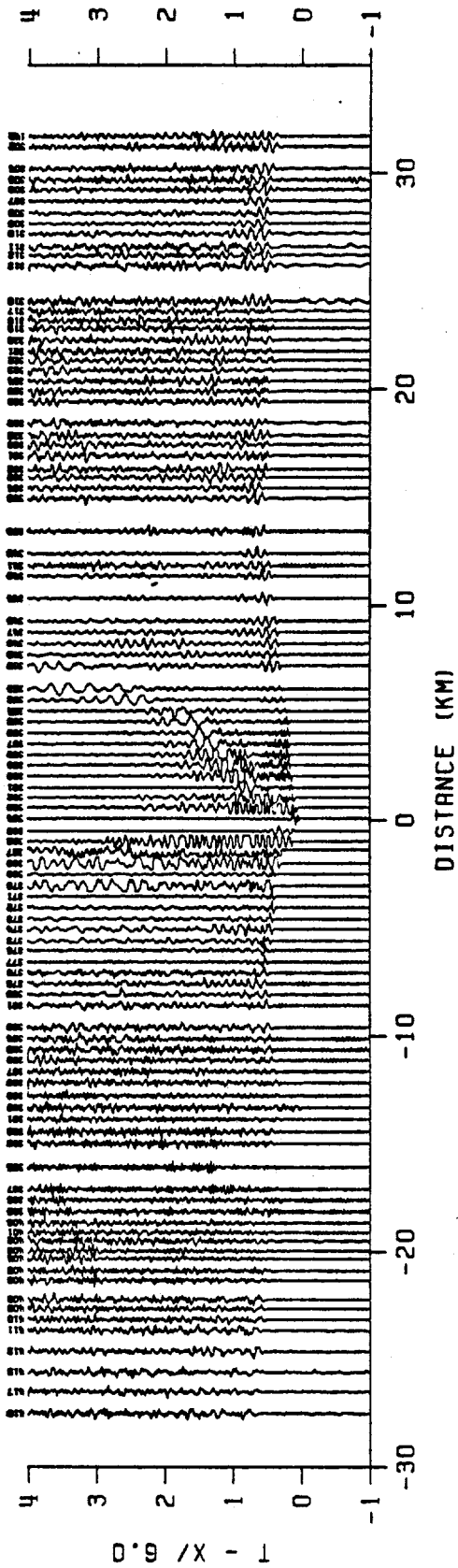

Shot 17, Shotpoint 2

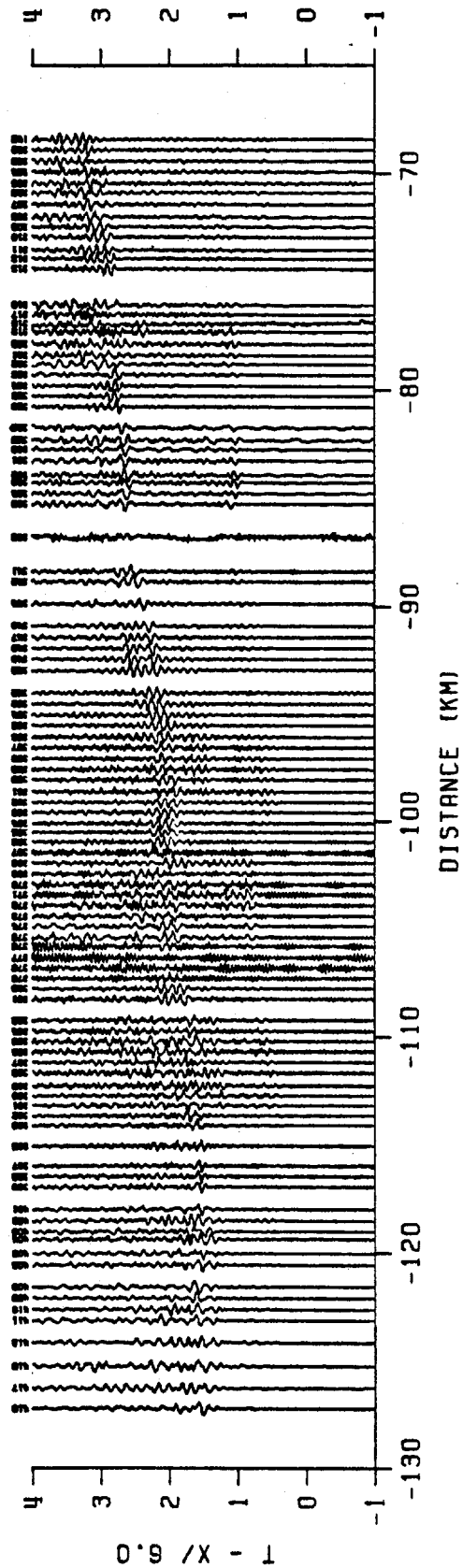

Shot 18, Shotpoint 7 (Offset)

Figure 10: Record Sections From the Vidal Line

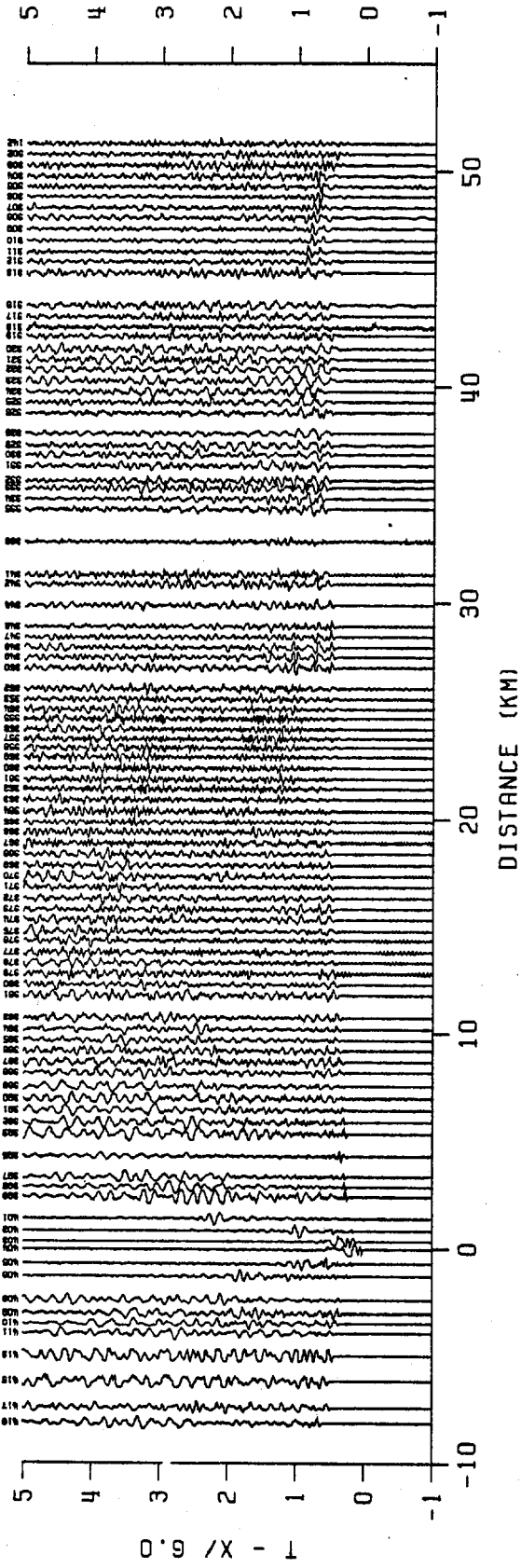

Shot 19, Shotpoint 1

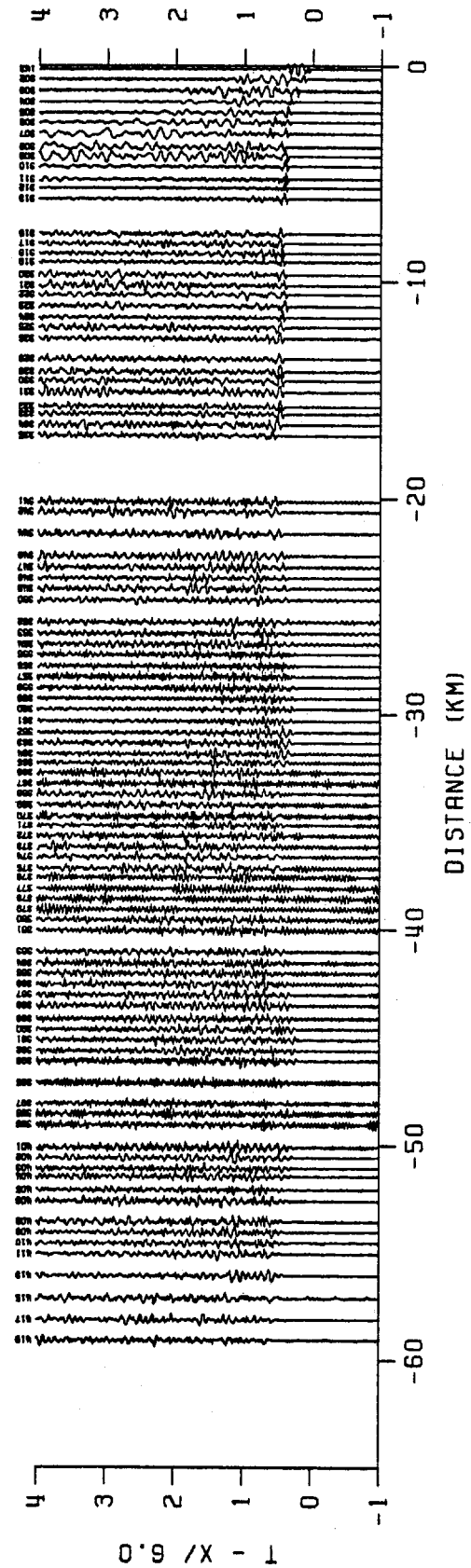

Shot 20, Shotpoint 4

Figure 11: Record Sections From the Vidal Line

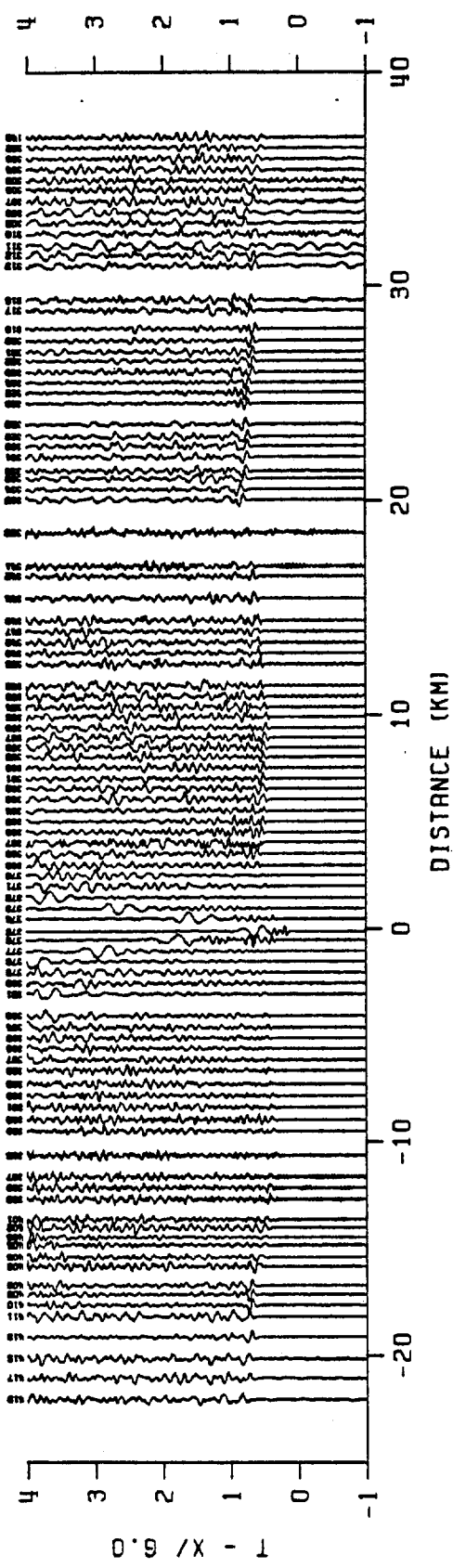

Shot 21, Shotpoint 15

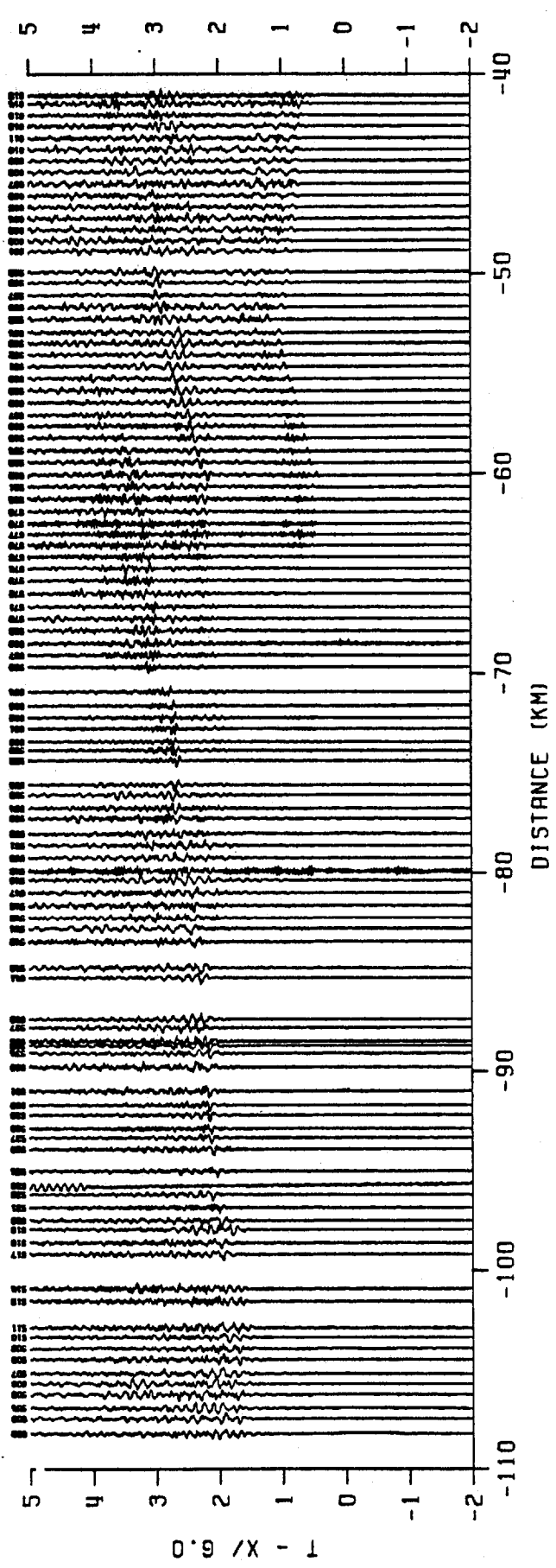

Shot 22, Shotpoint 12 (Offset)

Figure 12: Record Sections From the Vidal (Top) and Dutch Flat (Bottom) Lines.

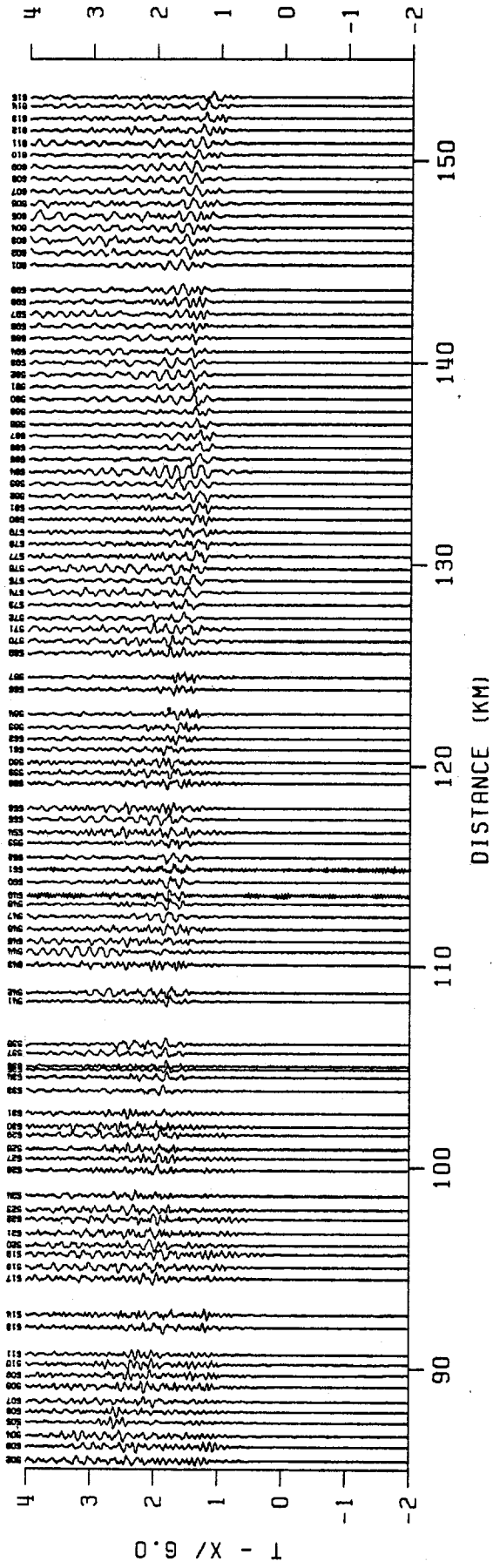

Shot 23, Shotpoint 14 (Offset)

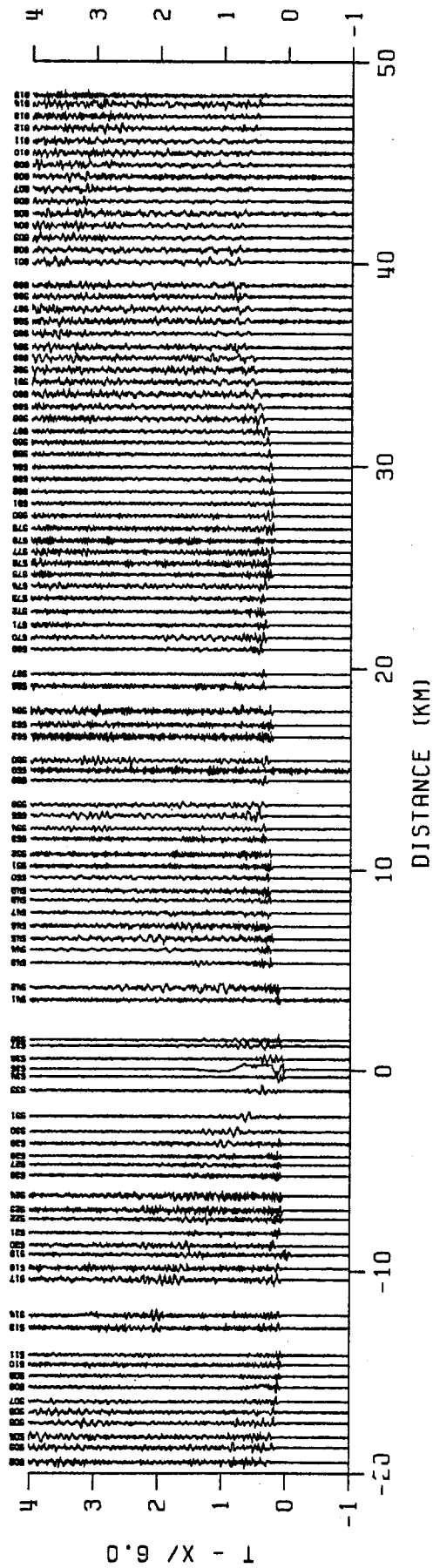

Shot 24, Shotpoint 5

Figure 13: Record Sections From the Dutch Flat Line

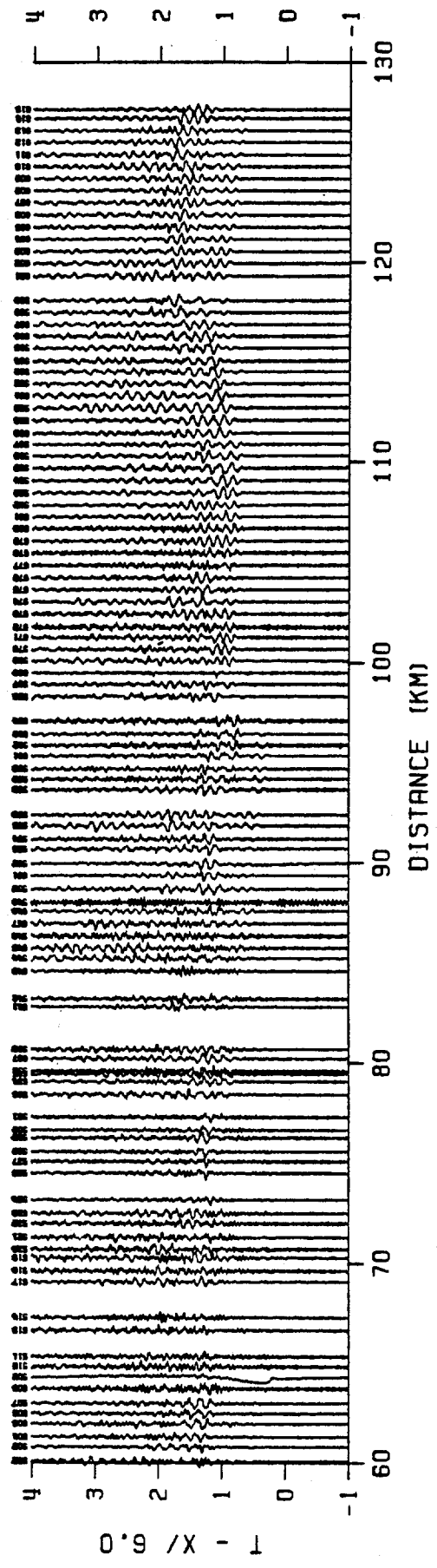

Shot 25, Shotpoint 11 (Fan)

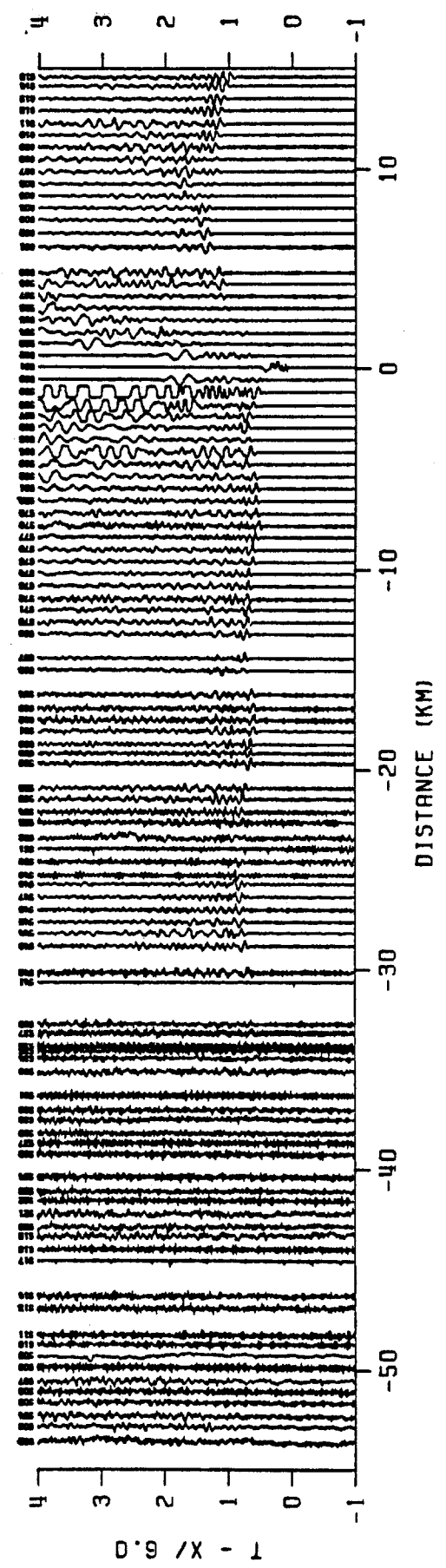

Shot 26, Shotpoint 16

Figure 14: Record Sections From the Dutch Flat Line

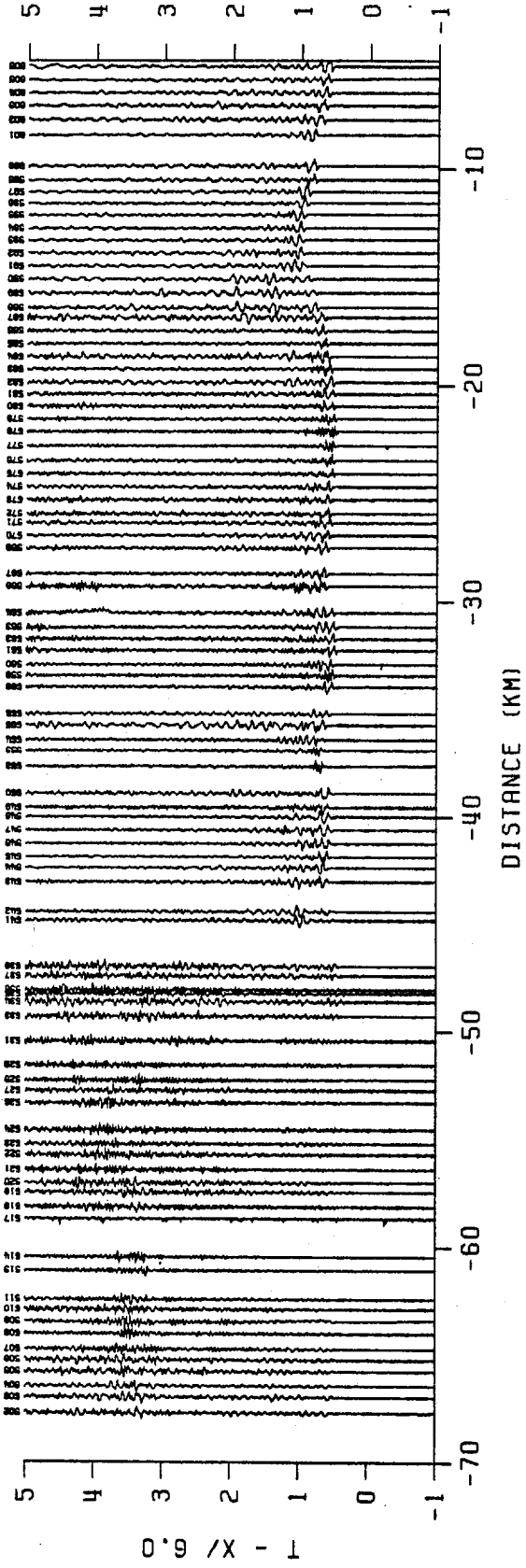

Shot 27, Shotpoint 7

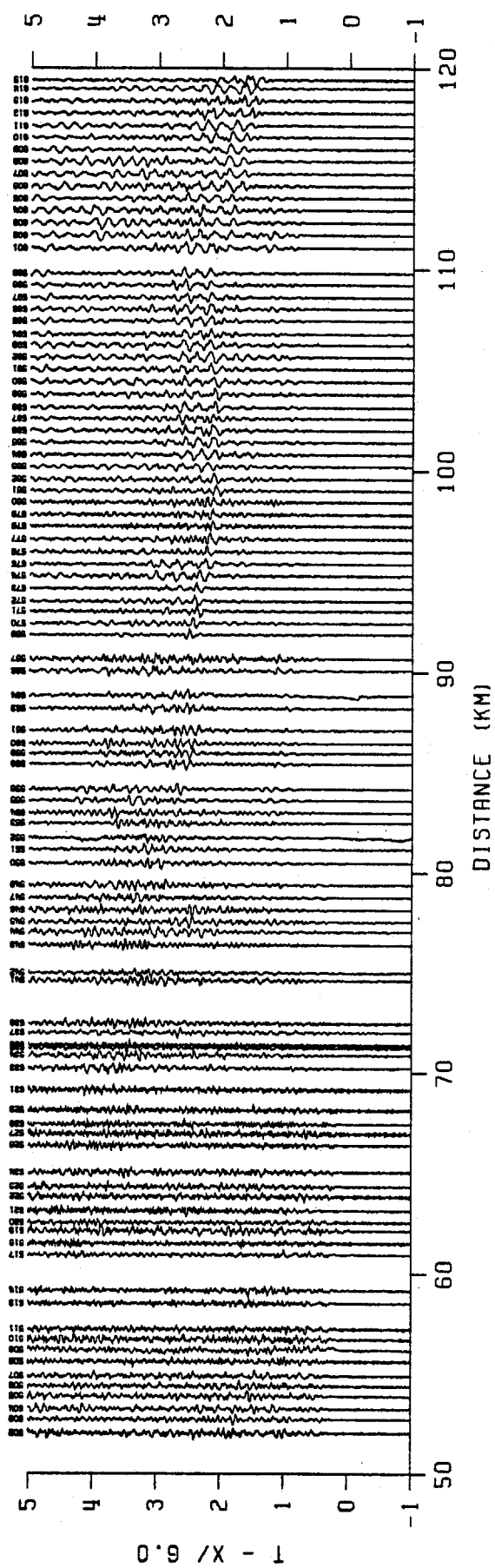

Shot 28, Shotpoint 1 (Offset)

Figure 15: Record Sections From the Dutch Flat Line

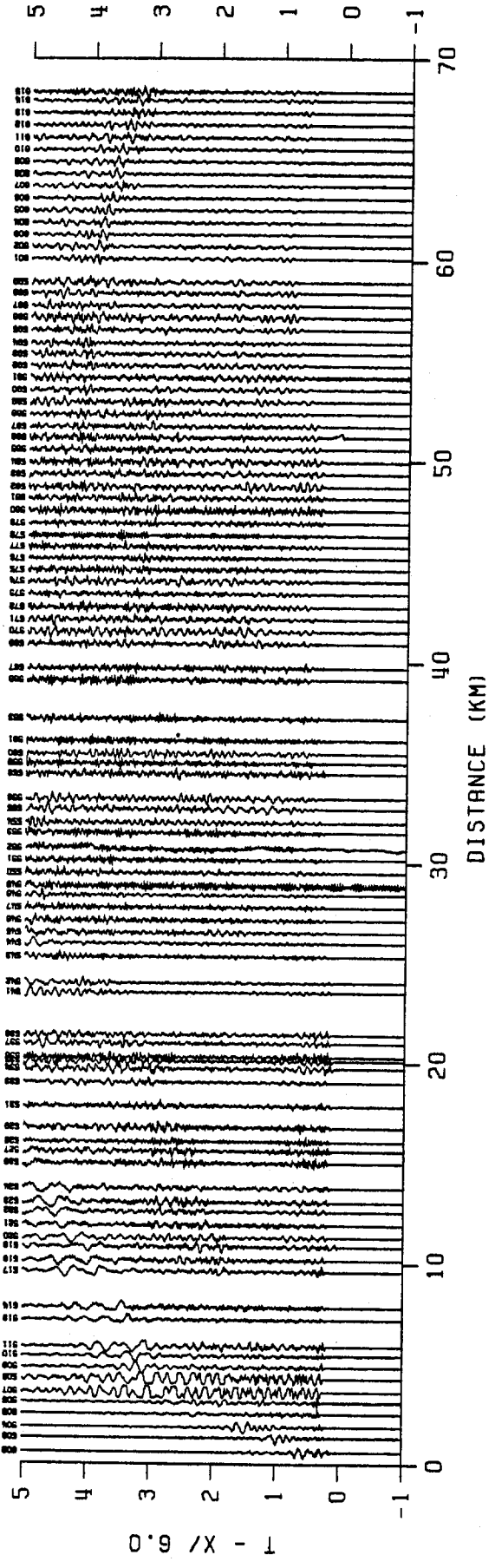

Shot 29, Shotpoint 4

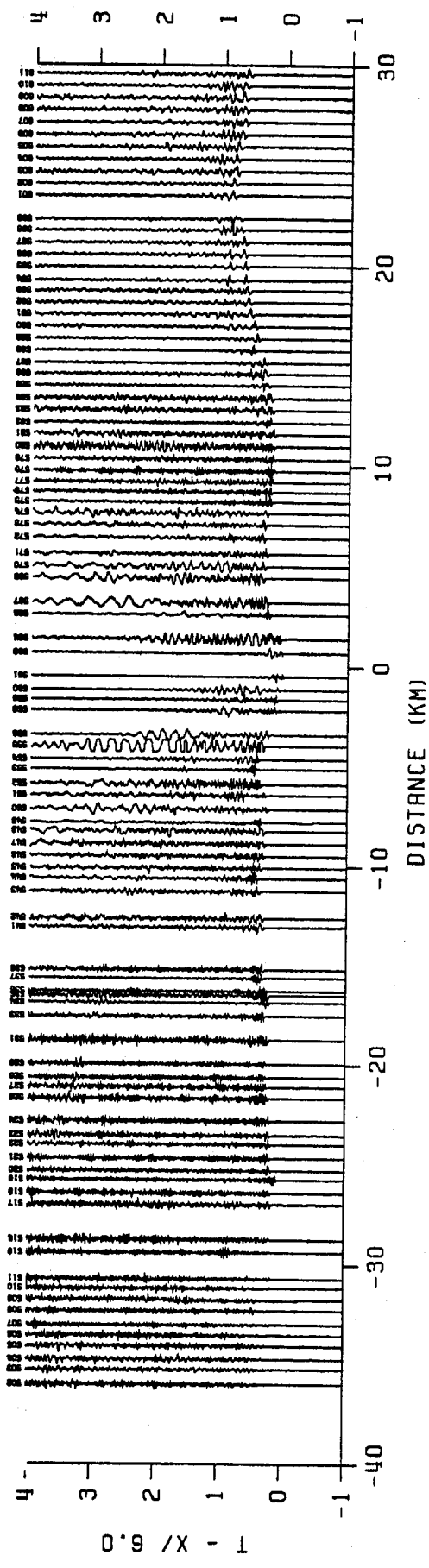

Shot 30, Shotpoint 6

Figure 16: Record Sections From the Dutch Flat Line

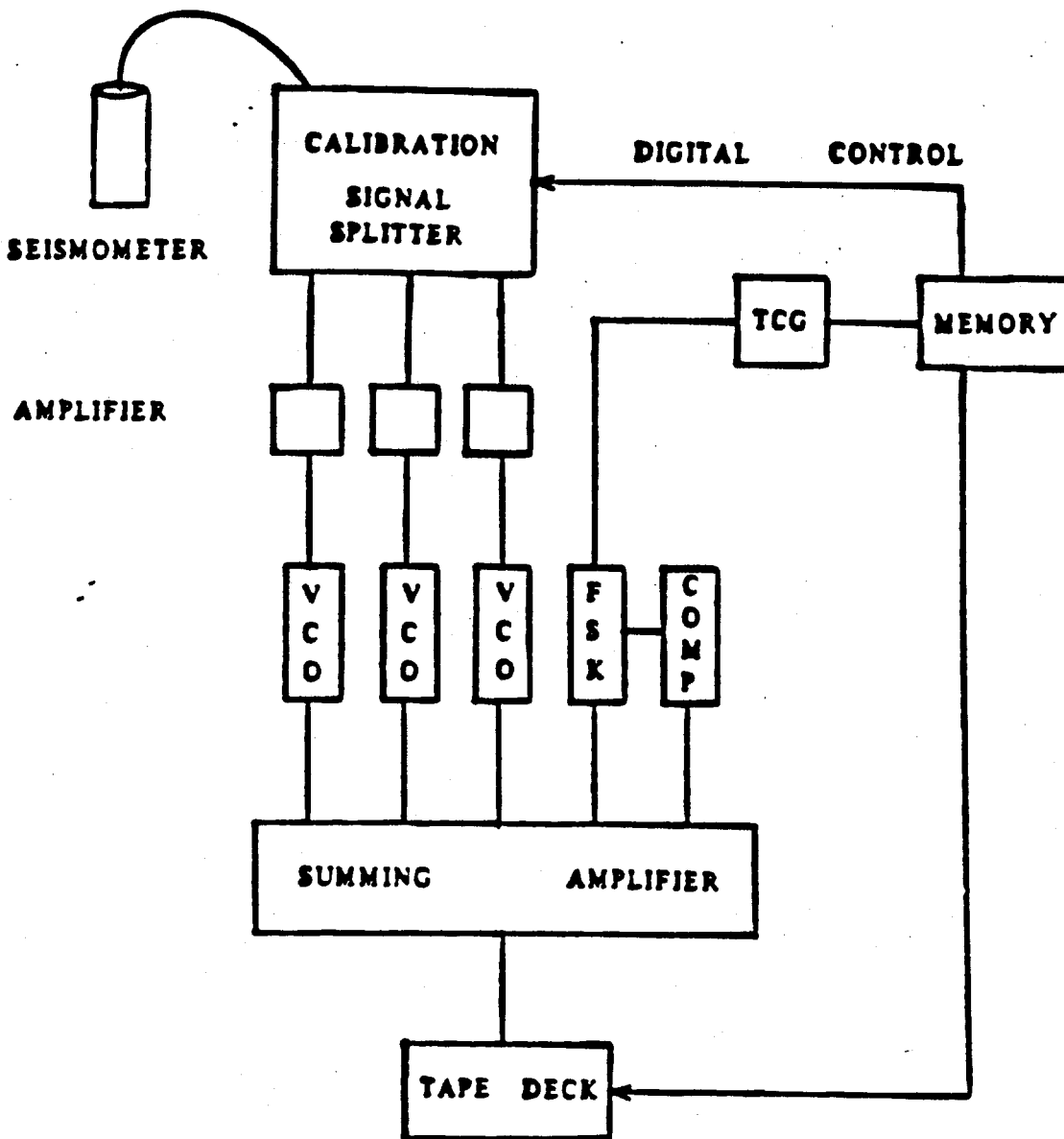

COMP = COMPENSATION
 FSK = FREQUENCY SHIFT KEYING
 TCG = TIME CODE GENERATOR
 VCO = VOLTAGE-CONTROLLED OSCILLATOR

Figure 17: Schematic diagram of seismic recorders

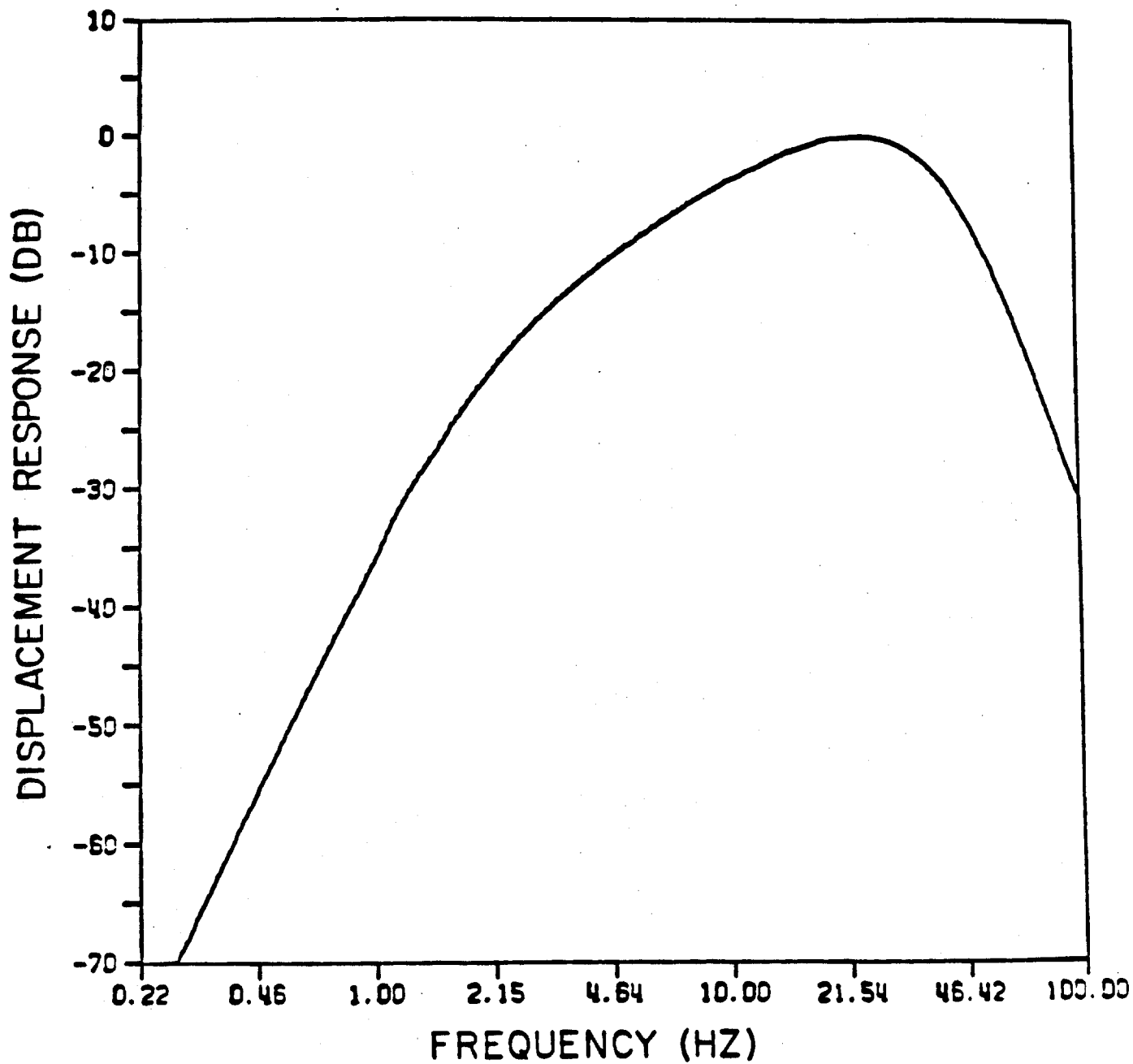

Figure 18: System response curve for cassette recording units with 2-Hz seismometers

Table 1: Master Shot List. Includes the shot number, shotpoint number, date (calendar and Julian), and shot time (GMT), latitude (degrees, minutes), longitude (degrees, minutes), charge size (lbs), and notes pertaining to each shot.

Chemehuevi Deployment

Shot Number	Shot Point	Date Shot Time	Latitude Longitude	Size (lbs)
1	8	NOV 5, 1985 309 7 0 0.011	34 1.1915 114 16.0732	3000
2	11	NOV 5, 1985 309 7 2 0.009	35 4.6421 115 9.4429	4000
3	13	NOV 5, 1985 309 7 4 0.017	33 37.5355 113 58.3179	4000
4	9	NOV 5, 1985 309 7 6 0.013	34 31.9558 114 36.7720	4000
5	9	NOV 5, 1985 309 7 30 0.014	34 31.9558 114 36.7720	500
6	17 ^{8X}	NOV 5, 1985 309 9 0 0.011	34 4.4078 114 17.8740	1000
7	10	NOV 5, 1985 309 9 2 0.010	34 48.5139 114 55.9536	3000
8	19 ^{4A}	NOV 5, 1985 309 9 4 0.007	34 16.0713 114 29.0464	2000
9	18 ^{9X}	NOV 5, 1985 309 9 6 0.011	34 25.8152 114 32.6694	1000
10	18 ^{9X}	NOV 5, 1985 309 9 30 0.013	34 25.8152 114 32.6694	500

Vidal Deployment

Shot Number	Shot Point	Date Shot Time	Latitude Longitude	Size (lbs)
11	12	NOV 7, 1985 312 6 0 0.006	34 54.5559 113 34.6748	4000
12	11	NOV 7, 1985 312 6 2 0.010	35 4.6421 115 9.4429	2000
13	14	NOV 7, 1985 312 6 4 0.008	33 37.0963 114 59.0605	2100
14	3	NOV 7, 1985 312 6 6 0.010	34 6.3268 114 31.1450	1000
15	2	NOV 7, 1985 312 6 8 0.013	34 0.1779 114 38.7549	1000
16	3	NOV 7, 1985 312 6 30 0.011	34 6.3268 114 31.1450	500
17	2	NOV 7, 1985 312 6 34 0.013	34 0.1779 114 38.7549	500
18	7	NOV 8, 1985 312 9 0 0.007	34 41.4065 113 56.3975	3000
19	1	NOV 8, 1985 312 9 2 0.006	33 49.8256 114 43.1675	2000
20	4 ⁻⁴⁶	NOV 8, 1985 312 9 4 0.010	34 13.4583 114 25.5533	2000
21	15 ^{-1X}	NOV 8, 1985 312 9 6 0.013	33 57.3845 114 40.0010	500

Dutch Flat Deployment

Shot Number	Shot Point	Date	Shot Time	Latitude Longitude	Size (lbs)
22	12	NOV 12, 1985	317 6 0 2.930	34 54.5559 113 34.6748	2400
23	14	NOV 12, 1985	317 6 2 0.011	33 37.0963 114 59.0605	3200
24	5	NOV 12, 1985	317 6 4 0.154	34 21.4211 114 16.7134	1000
25	11	NOV 12, 1985	317 6 6 0.010	35 4.6421 115 9.4429	2000
26	16 = GX	NOV 12, 1985	317 6 8 0.010	34 34.5605 114 1.0605	1000
27	7	NOV 13, 1985	317 9 0 0.008	34 41.4065 113 56.3975	2000
28	1	NOV 13, 1985	317 9 2 0.011	33 49.8256 114 43.1675	3000
29	4	NOV 13, 1985	317 9 4 0.010	34 13.4583 114 25.5533	2000
30	6	NOV 13, 1985	317 9 8 0.010	34 27.9460 114 9.3169	720

Table 2: Seismic Recorder Locations. Includes location number (see Figure 1), latitude, longitude, and elevation.

Chemehuevi Deployment

Location number	Latitude (deg,min)	Longitude (deg,min)	Elev (m)	Location number	Latitude (deg,min)	Longitude (deg,min)	Elev (m)	Location number	Latitude (deg,min)	Longitude (deg,min)	Elev (m)
101	33 50.358	114 6.620	382	153	34 18.347	114 29.784	580	204	34 41.497	114 47.861	646
102	33 51.235	114 7.655	345	154	34 18.672	114 30.358	545	205	34 41.897	114 48.316	658
103	33 52.097	114 8.710	343	155	34 19.135	114 30.686	518	206	34 42.292	114 48.787	670
104	33 52.975	114 9.752	303	156	34 19.842	114 30.588	498	207	34 42.686	114 49.247	670
105	33 53.937	114 9.747	294	157	34 20.337	114 30.866	475	208	34 43.077	114 49.711	658
106	33 54.804	114 9.921	287	158	34 20.847	114 31.104	445	209	34 43.468	114 50.184	649
107	33 55.685	114 10.778	275	159	34 21.417	114 31.282	422	210	34 43.861	114 50.639	638
108	33 56.550	114 11.835	265	160	34 22.012	114 31.407	402	211	34 44.266	114 51.098	627
109	33 57.405	114 13.018	256	161	34 22.448	114 31.742	387	212	34 44.661	114 51.567	615
110	33 58.289	114 12.999	228	162	34 22.973	114 31.973	371	213	34 45.036	114 52.022	603
111	33 59.153	114 13.005	198	163	34 23.519	114 32.156	353	214	34 45.447	114 52.487	593
112	33 59.982	114 13.702	182	164	34 24.132	114 32.234	332	215	34 45.851	114 52.949	593
113	34 0.644	114 15.221	165	165	34 24.700	114 32.385	310	216	34 46.239	114 53.421	591
114	34 1.214	114 16.111	152	166	34 25.241	114 32.505	302	217	34 46.641	114 53.884	591
115	34 1.579	114 16.541	149	167	34 25.826	114 32.709	292	218	34 47.045	114 54.343	591
116	34 2.125	114 16.675	149	168	34 26.290	114 33.029	311	219	34 47.441	114 54.809	591
117	34 2.631	114 17.032	148	169	34 26.768	114 33.307	331	220	34 47.830	114 55.266	601
118	34 3.155	114 17.285	131	170	34 27.249	114 33.573	348	221	34 48.220	114 55.709	619
119	34 3.745	114 17.316	131	171	34 27.758	114 33.805	368	222	34 48.540	114 56.040	639
120	34 4.309	114 17.642	114	172	34 28.300	114 34.046	390				
121	34 4.899	114 17.890	108	173	34 28.761	114 34.327	411				
122	34 4.734	114 18.090	108	174	34 29.294	114 34.521	438				
123	34 5.183	114 18.493	105	175	34 29.842	114 34.765	459				
124	34 5.535	114 18.823	106	176	34 30.310	114 35.100	486				
125	34 6.260	114 18.686	107	177	34 30.776	114 35.399	511				
126	34 6.501	114 19.326	109	178	34 31.269	114 35.707	525				
127	34 6.949	114 19.898	108	179	34 31.648	114 36.233	535				
128	34 7.225	114 20.725	108	180	34 31.964	114 36.864	524				
129	34 7.808	114 20.547	106	181	34 32.340	114 37.295	522				
131	34 8.717	114 21.263	135	182	34 32.736	114 37.754	526				
132	34 9.059	114 21.792	153	183	34 33.130	114 38.210	527				
133	34 9.546	114 21.919	176	184	34 33.634	114 38.777	525				
134	34 10.059	114 22.315	204	185	34 33.939	114 39.129	523				
136	34 10.815	114 23.337	234	186	34 34.331	114 39.609	515				
137	34 11.182	114 24.159	245	187	34 34.738	114 40.058	512				
138	34 11.500	114 24.502	259	188	34 35.127	114 40.516	512				
139	34 11.878	114 24.878	278	189	34 35.530	114 40.975	512				
140	34 12.537	114 25.161	306	190	34 35.922	114 41.433	512				
141	34 12.926	114 25.465	327	191	34 36.313	114 41.884	513				
142	34 13.387	114 25.994	352	192	34 36.722	114 42.349	515				
143	34 13.767	114 26.191	352	193	34 37.121	114 42.813	518				
144	34 14.234	114 26.629	364	194	34 37.503	114 43.258	523				
145	34 14.444	114 27.399	384	195	34 37.900	114 43.708	530				
146	34 14.957	114 27.670	408	196	34 38.305	114 44.177	539				
147	34 15.467	114 27.914	428	197	34 38.704	114 44.640	547				
148	34 15.894	114 28.329	441	198	34 39.117	114 45.119	560				
149	34 16.093	114 28.995	452	199	34 39.512	114 45.572	573				
150	34 16.824	114 29.077	490	200	34 39.914	114 46.022	588				
151	34 17.512	114 29.011	522	201	34 40.309	114 46.481	601				
152	34 17.967	114 29.384	551	203	34 41.096	114 47.410	629				

Vidal Deployment

Location number	Latitude (deg,min)	Longitude (deg,min)	Elev (m)	Location number	Latitude (deg,min)	Longitude (deg,min)	Elev (m)	Location number	Latitude (deg,min)	Longitude (deg,min)	Elev (m)
302	34 13.149	114 25.740	334	352	34 2.537	114 35.946	365	402	33 50.184	114 42.833	281
303	34 12.928	114 25.957	320	353	34 2.353	114 36.212	371	403	33 50.003	114 43.103	272
304	34 12.690	114 26.122	310	354	34 2.171	114 36.462	378	404	33 49.830	114 43.206	269
305	34 12.551	114 26.446	304	355	34 2.002	114 36.711	387	405	33 49.616	114 43.563	267
306	34 12.293	114 26.525	292	356	34 1.818	114 36.988	397	406	33 49.464	114 43.890	262
307	34 12.150	114 26.870	294	357	34 1.649	114 37.238	396	407	33 49.296	114 44.198	256
308	34 12.105	114 27.379	301	358	34 1.534	114 37.604	411	408	33 49.162	114 44.515	248
309	34 11.774	114 27.380	292	359	34 1.362	114 37.852	408	409	33 49.060	114 44.898	241
310	34 11.420	114 27.354	275	360	34 1.107	114 37.978	391	410	33 48.845	114 45.106	235
311	34 11.303	114 27.794	275	361	34 0.889	114 38.229	389	411	33 48.598	114 45.264	230
312	34 11.013	114 27.780	265	362	34 0.731	114 38.529	372	412	33 48.214	114 45.754	220
313	34 10.712	114 27.834	256	363	34 0.477	114 38.647	357	413	33 47.911	114 46.451	220
314	34 10.434	114 27.872	252	364	34 0.209	114 38.772	353	414	33 47.728	114 47.248	210
315	34 10.226	114 28.172	243	365	33 59.908	114 38.754	339	417	33 47.728	114 47.248	210
316	34 10.281	114 28.889	251	366	33 59.652	114 38.851	326	419	33 47.145	114 47.338	207
317	34 9.969	114 28.903	243	367	33 59.397	114 38.976	316				
318	34 9.615	114 28.835	233	368	33 59.138	114 39.089	309				
319	34 9.384	114 28.885	225	369	33 58.880	114 39.232	299				
320	34 9.040	114 28.950	222	370	33 58.617	114 39.355	292				
321	34 8.846	114 29.193	213	371	33 58.359	114 39.465	286				
322	34 8.648	114 29.343	216	372	33 58.093	114 39.571	281				
323	34 8.339	114 29.389	200	373	33 57.833	114 39.696	277				
324	34 8.090	114 29.537	201	374	33 57.596	114 39.827	302				
325	34 7.868	114 29.704	195	375	33 57.329	114 39.971	267				
326	34 7.620	114 29.842	189	376	33 57.108	114 40.075	276				
327	34 7.380	114 30.044	188	377	33 56.844	114 40.219	284				
328	34 7.292	114 30.365	190	378	33 56.595	114 40.333	292				
329	34 7.073	114 30.636	190	379	33 56.388	114 40.455	298				
330	34 6.880	114 30.799	189	380	33 56.088	114 40.575	304				
331	34 6.659	114 31.004	188	381	33 55.831	114 40.695	305				
332	34 6.305	114 31.145	190	382	33 55.567	114 40.823	305				
333	34 6.207	114 31.369	198	383	33 55.316	114 40.942	310				
334	34 5.978	114 31.552	208	384	33 55.044	114 41.068	320				
335	34 5.769	114 31.746	216	385	33 54.796	114 41.190	329				
336	34 5.540	114 31.926	225	386	33 54.547	114 41.307	328				
337	34 5.374	114 32.203	234	387	33 54.283	114 41.434	332				
338	34 5.153	114 32.400	243	388	33 54.031	114 41.556	339				
339	34 4.879	114 32.547	255	389	33 53.712	114 41.695	337				
340	34 4.696	114 32.799	259	390	33 53.399	114 41.713	352				
341	34 4.538	114 33.109	268	391	33 53.087	114 41.713	365				
342	34 4.366	114 33.336	277	392	33 52.756	114 41.701	391				
343	34 4.176	114 33.613	286	393	33 52.447	114 41.701	400				
344	34 4.007	114 33.860	294	394	33 52.158	114 41.730	390				
345	34 3.814	114 34.137	303	395	33 51.829	114 41.740	365				
346	34 3.638	114 34.322	313	396	33 51.642	114 41.969	344				
347	34 3.454	114 34.655	323	397	33 51.299	114 41.899	347				
348	34 3.263	114 34.902	332	398	33 51.033	114 41.980	326				
349	34 3.098	114 35.162	338	399	33 50.752	114 42.055	307				
350	34 2.908	114 35.427	348	400	33 50.485	114 42.169	304				
351	34 2.718	114 35.698	326	401	33 50.308	114 42.474	293				

Dutch Flat Deployment

Location number	Latitude (deg,min)	Longitude (deg,min)	Elev (m)	Location number	Latitude (deg,min)	Longitude (deg,min)	Elev (m)	Location number	Latitude (deg,min)	Longitude (deg,min)	Elev (m)
502	34 13.740	114 23.378	416	552	34 25.349	114 11.552	338	602	34 37.814	113 58.992	672
503	34 13.988	114 24.993	382	553	34 25.584	114 11.129	361	603	34 38.169	113 58.884	679
504	34 14.187	114 24.748	439	554	34 25.799	114 10.910	381	604	34 38.447	113 58.670	690
505	34 14.421	114 24.410	428	555	34 26.073	114 10.635	396	605	34 38.712	113 58.441	701
506	34 14.550	114 24.052	416	556	34 26.346	114 10.481	413	606	34 38.996	113 58.238	714
507	34 14.750	114 23.823	435	557	34 26.634	114 10.284	435	607	34 39.277	113 58.021	727
508	34 15.117	114 23.621	451	558	34 26.920	114 10.044	462	608	34 39.557	113 57.797	740
509	34 15.365	114 23.406	475	559	34 27.198	114 9.908	463	609	34 39.834	113 57.598	756
510	34 15.541	114 23.090	499	560	34 27.520	114 9.872	484	610	34 40.114	113 57.389	771
511	34 15.799	114 22.970	579	561	34 27.770	114 9.569	496	611	34 40.378	113 57.169	788
512	34 16.078	114 22.564	652	562	34 27.957	114 9.293	513	612	34 40.664	113 56.945	806
513	34 16.308	114 22.353	719	563	34 28.092	114 8.914	530	613	34 40.937	113 56.736	822
514	34 16.608	114 22.138	670	564	34 28.280	114 8.505	548	614	34 41.239	113 56.550	840
515	34 16.860	114 21.795	640	565	34 28.508	114 8.195	573	615	34 41.423	113 56.382	855
516	34 17.085	114 21.592	713	566	34 28.740	114 7.916	588				
517	34 17.413	114 21.498	688	567	34 28.963	114 7.626	602				
518	34 17.631	114 21.239	627	568	34 29.232	114 7.415	621				
519	34 17.843	114 20.870	594	569	34 29.403	114 7.033	633				
520	34 17.949	114 20.579	571	570	34 29.606	114 6.732	652				
521	34 18.109	114 20.185	536	571	34 29.802	114 6.405	670				
522	34 18.462	114 19.993	505	572	34 29.659	114 5.657	658				
523	34 18.737	114 19.906	487	573	34 29.910	114 5.354	658				
524	34 18.996	114 19.565	451	574	34 30.147	114 5.074	650				
525	34 19.447	114 19.545	560	575	34 30.433	114 4.883	652				
526	34 19.884	114 19.584	609	576	34 30.748	114 4.734	658				
527	34 20.140	114 19.367	609	577	34 31.179	114 4.726	684				
528	34 20.356	114 19.193	609	578	34 31.672	114 4.813	710				
529	34 20.634	114 18.912	576	579	34 31.848	114 4.467	682				
530	34 20.651	114 18.474	487	580	34 32.060	114 4.145	664				
531	34 20.824	114 18.034	390	581	34 32.194	114 3.738	644				
532	34 20.856	114 17.445	298	582	34 32.375	114 3.426	630				
533	34 21.083	114 17.240	274	583	34 32.605	114 3.124	622				
534	34 21.302	114 16.870	219	584	34 32.858	114 2.884	673				
535	34 21.441	114 16.687	219	585	34 33.060	114 2.540	601				
536	34 21.341	114 16.361	318	586	34 33.302	114 2.284	600				
537	34 21.499	114 15.927	249	587	34 33.624	114 2.165	600				
538	34 21.740	114 15.819	306	588	34 33.649	114 1.626	598				
539	34 22.205	114 15.505	237	589	34 34.025	114 1.521	598				
540	34 22.430	114 15.353	217	590	34 34.315	114 1.303	604				
541	34 22.714	114 15.056	176	591	34 34.584	114 1.066	610				
542	34 22.627	114 14.493	144	592	34 34.843	114 0.834	615				
543	34 23.389	114 14.201	143	593	34 35.108	114 0.602	621				
544	34 23.634	114 13.892	183	594	34 35.365	114 0.423	625				
545	34 23.738	114 13.510	181	595	34 35.585	114 0.075	627				
546	34 23.954	114 13.201	208	596	34 35.778	113 59.744	640				
547	34 24.131	114 12.821	291	597	34 35.969	113 59.424	648				
548	34 24.340	114 12.483	303	598	34 36.170	113 59.089	657				
549	34 24.488	114 12.243	274	599	34 36.519	113 59.000	661				
550	34 24.739	114 11.937	303	600	34 36.954	113 59.000	664				
551	34 25.161	114 11.860	318	601	34 37.382	113 59.002	667				

Appendix A

Field Data Tables. These include information related to the seismic recorders. Each set of 20 recorders is given a team number under which data is stored and referenced. Each table contains shot number, shotpoint numbers, team number, and shot time given in julian day, hour, minute, and second. Column headings for the table are explained below:

Loc	- location number from the seismic recorder location (see Table 2).
Dist (km)	- distance in kilometers from the shotpoint to the recorder.
Azim	- azimuth from the shotpoint to the recorder. (in degrees clockwise from north).
Unit	- I.D. number of the recording unit.
Chron	- chronometer correction for the recorder at shot time (interpolated from the total clock drift).
C1, C2, C3	- amplifier attenuation setting (db) for each of three data-recording channels. The gain of each channel is determined by subtracting the given attenuation from a total gain of 96 db.

Tape Grade Scale

Scale is a listing of all tape grade numbers used on the Field Data Tables. Each number corresponds to the performance of each recording unit.

0	Good, tape ran
1	Tape did not run
2	Tape ran, no signal
3	Bad time code
4	Skipped record time
5	Not deployed
6	Clipped seismic trace
01	Filtered, 2-15 Hz band-pass

FIELD DATA TABLE

SHOT NUMBER 1 SHOT POINT 8 TEAM 3
 SHOT TIME: 309: 7: 0: 0.011

LOC	DIST(KM)	AZIM.	UNIT	CHRON	CHAN	C1	C2	C3	TAPE	GRADE
1	121	6.539	334.7	41	3	1	30	12 88	0	0
2	122	7.247	334.7	42	2	1	30	12 88	0	0
3	123	9.266	333.2	43	2	1	30	12 68	0	0
4	124	9.076	332.2	44	6	1	30	12 68	0	0
5	125	10.195	336.8	45	-2	1	30	12 68	0	0
6	126	11.017	333.0	46	9	3	30	12 68	0	0
7	127	12.162	331.1	47	19	3	30	12 48	0	0
8	128	13.254	327.3	48	-21	3	30	12 48	0	0
9	129	14.036	330.7	49	3	1	30	12 48	0	0
10	131	16.041	330.2	50	6	3	30	12 48	0	0
11	132	17.014	328.9	51	3	1	30	12 48	0	0
12	133	17.871	329.8	52	-2	1	30	12 48	0	0
13	134	19.062	329.8	53	4	1	30	12 48	0	0
14	136	21.008	327.9	54	4	1	30	12 48	0	0
15	137	22.266	326.1	55	-17	1	30	12 48	0	0
16	138	23.048	325.8	56	0	1	30	12 48	0	0
17	139	24.033	325.7	57	0	1	30	12 48	0	0
18	140	25.204	326.4	58	6	1	30	12 48	0	0
19	141	26.061	326.4	59	-2	1	30	12 48	0	0
20	143	51.605	147.9	60	-4	2	30	12 48	0	0

FIELD DATA TABLE

SHOT NUMBER 1 SHOT POINT 8 TEAM 1
 SHOT TIME: 309: 7: 0: 0.011

LOC	DIST(KM)	AZIM	UNIT	CHRON	CHAN	C1	C2	C3	TAPE	GRADE
1	142	26.882	327.0	1	2	1	30	12 48	0	0
2	143	27.974	326.3	2	-9	1	30	12 48	0	0
3	144	29.065	326.1	3	6	1	30	12 48	0	0
4	145	30.058	324.7	4	-30	2	30	12 68	0	0
5	146	31.072	325.0	5	7	2	30	12 68	0	0
6	147	32.059	325.5	6	2	2	30	12 68	1	0
7	148	33.071	325.3	7	-13	2	30	12 88	0	0
8	169	54.187	330.8	8	-15	2	30	12 68	2	0
9	170	55.161	330.9	9	19	2	30	12 68	0	0
10	171	56.156	331.1	10	30	2	30	12 68	0	0
11	172	57.212	331.2	11	-11	2	30	12 48	0	0
12	173	58.167	331.3	12	0	2	30	12 48	0	0
13	174	59.172	331.5	13	-5	2	30	12 48	0	0
14	175	60.241	331.6	14	4	2	30	12 48	0	0
15	176	61.247	331.6	15	1	2	30	12 68	0	0
16	177	62.222	331.6	16	8	2	30	12 68	0	0
17	178	63.248	331.6	17	5	2	30	12 68	0	0
18	179	64.248	331.3	18	-9	2	30	12 88	0	0
19	180	65.229	330.8	19	-9	2	30	12 88	3	0
20	181	66.158	330.6	20	0	2	30	12 88	0	0

FIELD DATA TABLE

SHOT NUMBER 1 SHOT POINT 8 TEAM 4
 SHOT TIME: 309: 7: 0: 0.011

LOC	DIST(KM)	AZIM	UNIT	CHRON	CHAN	C1	C2	C3	TAPE	GRADE
1	182	67.143	330.4	61	10	2	30	12 68	0	0
2	183	68.121	330.2	62	9	2	30	12 68	0	0
3	184	69.363	330.0	63	9	2	30	12 68	0	0
4	185	70.122	329.8	64	5	2	30	12 48	0	0
5	186	71.119	329.6	65	-24	2	30	12 48	0	0
6	187	72.116	329.4	66	6	2	30	12 48	0	0
7	188	73.092	329.2	67	-9	2	30	12 48	0	0
8	189	74.092	329.1	68	-10	2	30	12 48	0	0
9	190	75.076	328.9	69	5	2	30	12 48	0	0
10	191	76.054	328.7	70	11	2	30	12 48	0	0
11	192	77.069	328.6	71	-11	2	30	12 48	0	0
12	193	78.068	328.4	72	-9	2	30	12 48	0	0
13	194	79.028	328.3	73	6	2	30	12 48	0	0
14	195	80.016	328.1	74	2	2	30	12 48	0	0
15	196	81.031	328.0	75	10	2	30	12 48	2	0
16	197	82.032	327.9	76	32	2	30	12 48	0	0
17	198	83.070	327.7	77	6	2	30	12 48	0	0
18	199	84.059	327.6	78	15	2	30	12 48	0	0
19	200	85.056	327.5	79	-11	2	30	12 48	0	0
20	201	86.049	327.3	80	3	2	30	12 48	0	0

FIELD DATA TABLE

SHOT NUMBER 1 SHOT POINT 8 TEAM 2
 SHOT TIME: 309: 7: 0: 0.011

LOC	DIST(KM)	AZIM	UNIT	CHRON	CHAN	C1	C2	C3	TAPE	GRADE
1	120	6.249	337.3	21	1	1	30	12 88	0	0
2	119	5.093	337.9	22	5	3	30	12 48	0	0
3	118	4.082	332.8	23	3	3	30	12 68	0	0
4	117	3.044	331.0	24	-7	3	30	12 68	0	0
5	116	1.958	331.8	25	-11	3	30	12 68	4	0
6	115	1.015	314.9	26	7	3	30	12 88	0	0
7	114	0.072	305.0	27	0	3	30	12 88	0	0
8	113	1.657	127.6	28	-28	3	30	12 68	0	0
9	112	4.281	121.5	29	6	3	30	12 68	0	0
10	111	6.042	128.6	30	3	1	30	12 48	0	0
11	110	7.156	138.6	31	57	3	30	12 48	0	0
12	109	8.435	146.1	32	6	3	30	12 48	3	0
13	108	10.782	142.7	33	11	3	30	12 48	0	0
14	107	13.044	141.3	34	4	1	30	12 48	0	0
15	106	15.141	141.2	35	-22	1	30	12 48	0	0
16	105	16.578	144.0	36	-2	1	30	12 48	0	0
17	104	18.044	147.3	37	2	1	30	12 48	2	0
18	103	20.284	146.0	38	3	1	30	12 48	0	0
19	102	22.518	144.8	39	3	1	30	12 48	0	0
20	101	24.766	143.9	40	2	1	30	12 48	0	0

FIELD DATA TABLE

SHOT NUMBER 1 SHOT POINT 8 TEAM 5
 SHOT TIME: 309: 7: 0: 0.011

LOC	DIST(KM)	AZIM	UNIT	CHRON	CHAN	C1	C2	C3	TAPE	GRADE
1	149	33.963	81	11	2	30	12	88	0	0
2	150	35.137	82	-10	1	30	12	88	0	0
3	151	36.135	83	16	2	30	12	68	0	0
4	152	37.151	84	-13	1	30	12	48	0	0
5	153	38.078	85	-18	2	30	12	48	0	0
6	154	39.067	86	0	2	30	12	48	0	0
7	156	41.064	87	-12	1	30	12	48	0	0
8	157	42.064	88	21	1	30	12	48	0	0
9	158	43.056	89	0	3	30	12	48	0	0
10	155	40.058	90	--	1	30	12	48	0	0
11	159	44.092	91	5	1	30	12	48	0	0
12	160	45.128	92	-3	2	30	12	48	0	0
13	161	46.084	93	-7	2	30	12	48	0	0
14	162	47.096	94	18	2	30	12	48	0	0
15	163	48.105	95	2	1	30	12	48	0	0
16	164	49.142	96	-34	2	30	12	68	0	0
17	165	50.165	97	5	2	30	12	68	0	0
18	166	51.124	98	-28	1	30	12	88	0	0
19	167	52.220	99	14	2	30	12	88	0	0
20	168	53.208	100	9	2	30	12	88	0	0

FIELD DATA TABLE

SHOT NUMBER 2 SHOT POINT 11 TEAM 1
 SHOT TIME: 309: 7: 2: 0.009

LOC	DIST(KM)	AZIM	UNIT	CHRON	CHAN	C1	C2	C3	TAPE	GRADE
1	142	116.055	144.5	1	2	1	30	12	48	0
2	143	114.953	144.7	2	-9	2	30	12	48	0
3	144	113.861	144.7	3	6	1	30	12	48	0
4	145	112.869	145.1	4	-30	2	30	12	68	0
5	146	111.852	145.0	5	7	2	30	12	68	0
6	147	110.864	144.9	6	2	2	30	12	68	1
7	148	109.852	144.9	7	-13	1	30	12	88	0
8	169	89.127	141.6	8	-15	1	30	12	68	3
9	170	88.177	141.5	9	19	1	30	12	68	0
10	171	87.218	141.3	10	30	2	30	12	68	0
11	172	86.204	141.0	11	-11	1	30	12	48	0
12	173	85.269	140.9	12	0	1	30	12	48	0
13	174	84.316	140.6	13	-5	1	30	12	48	0
14	175	83.295	140.4	14	4	1	30	12	48	0
15	176	82.299	140.3	15	1	1	30	12	68	0
16	177	81.344	140.2	16	8	1	30	12	68	0
17	178	80.340	140.0	17	5	1	30	12	68	0
18	179	79.289	140.1	18	-9	2	30	12	88	0
19	180	78.224	140.4	19	-9	2	30	12	88	3
20	181	77.269	140.5	20	0	1	30	12	88	0

FIELD DATA TABLE

SHOT NUMBER 2 SHOT POINT 11 TEAM 2
 SHOT TIME: 309: 7: 2: 0.009

LOC	DIST(KM)	AZIM	UNIT	CHRON	CHAN	C1	C2	C3	TAPE	GRADE
1	120	136.814	144.4	21	1	2	30	12	88	0
2	119	137.955	144.5	22	5	2	30	12	48	0
3	118	138.876	144.7	23	3	1	30	12	68	0
4	117	139.895	144.8	24	-7	2	30	12	68	0
5	116	140.977	144.8	25	-11	2	30	12	68	4
6	115	141.924	145.0	26	7	2	30	12	88	0
7	114	142.856	144.9	27	0	2	30	12	88	0
8	113	144.502	144.7	28	-28	2	30	12	68	0
9	112	146.846	144.2	29	6	2	30	12	68	0
10	111	148.716	144.2	30	3	2	30	12	48	0
11	110	150.031	144.6	31	57	1	30	12	48	0
12	109	151.357	144.9	32	6	1	30	12	48	3
13	108	153.694	144.7	33	11	2	30	12	48	0
14	107	155.936	144.6	34	4	2	30	12	48	0
15	106	158.028	144.5	35	-22	2	30	12	48	0
16	105	159.496	144.8	36	-2	2	30	12	48	0
17	104	160.958	145.1	37	2	2	30	12	48	3
18	103	163.206	145.0	38	3	2	30	12	48	0
19	102	165.439	144.8	39	3	2	30	12	48	0
20	101	167.681	144.7	40	2	2	30	12	48	0

FIELD DATA TABLE

SHOT NUMBER 1 SHOT POINT 8 TEAM 6
 SHOT TIME: 309: 7: 0: 0.011

LOC	DIST(KM)	AZIM	UNIT	CHRON	CHAN	C1	C2	C3	TAPE	GRADE
1	203	88.043	327.1	101	9	9	30	12	48	1
2	204	89.041	327.0	102	2	2	30	12	48	0
3	205	90.042	326.9	103	--	2	30	12	48	3
4	206	91.047	326.7	104	-3	2	30	12	48	0
5	207	92.042	326.6	105	5	2	30	12	48	0
6	208	93.037	326.5	106	-5	2	30	12	48	0
7	209	94.039	326.4	107	-8	2	30	12	48	0
8	210	95.031	326.3	108	5	2	30	12	48	0
9	211	96.044	326.2	109	1	2	30	12	48	0
10	213	98.015	326.0	110	6	1	30	12	48	0
11	214	99.041	325.9	111	17	2	30	12	48	0
12	215	100.057	325.8	112	-6	1	30	12	48	0
13	216	101.056	325.7	113	4	2	30	12	48	0
14	217	102.070	325.6	114	0	2	30	12	68	0
15	218	103.083	325.5	115	0	2	30	12	68	0
16	219	104.091	325.4	116	0	2	30	12	68	0
17	220	105.079	325.3	117	1	1	30	12	68	2
18	221	106.058	325.3	118	-3	1	30	12	88	0
19	222	106.832	325.2	119	2	1	30	12	88	0
20	11	142.923	325.4	120	--	--	30	12	88	3

FIELD DATA TABLE

SHOT NUMBER 2 SHOT POINT 11 TEAM 5
 SHOT TIME: 309: 7: 2: 0.009

LOC	DIST(KM)	AZIM	UNIT	CHRON	CHAN	C1	C2	C3	TAPE	GRADE
1	149	108.969	145.3	81	11	2	30	12 88	0	0
2	150	107.786	144.9	82	-10	2	30	12 88	0	0
3	151	106.800	144.5	83	16	2	30	12 68	0	0
4	152	105.783	144.5	84	-13	1	30	12 48	0	0
5	153	104.854	144.5	85	-18	2	30	12 48	0	0
6	154	103.858	144.7	86	0	2	30	12 48	0	0
7	156	101.886	144.2	87	-12	1	30	12 48	0	0
8	157	100.893	144.1	88	21	1	30	12 48	0	0
9	158	99.913	144.0	89	0	2	30	12 48	0	0
10	155	102.868	144.7	90	--	1	30	12 48	0	0
11	159	98.900	143.7	91	5	2	30	12 48	0	0
12	160	97.898	143.4	92	-3	2	30	12 48	0	0
13	161	96.943	143.4	93	-7	1	30	12 48	0	0
14	162	95.953	143.2	94	18	2	30	12 48	0	0
15	163	94.974	143.0	95	2	2	30	12 48	0	0
16	164	93.994	142.7	96	-34	1	30	12 68	0	0
17	165	93.017	142.4	97	5	1	30	12 68	0	0
18	166	92.111	142.1	98	-28	1	30	12 88	0	0
19	167	91.064	141.8	99	14	2	30	12 88	0	0
20	168	90.086	141.7	100	9		30	12 88	0	3

FIELD DATA TABLE

SHOT NUMBER 2 SHOT POINT 11 TEAM 3
 SHOT TIME: 309: 7: 2: 0.009

LOC	DIST(KM)	AZIM	UNIT	CHRON	CHAN	C1	C2	C3	TAPE	GRADE
1	121	136.474	144.5	41	3	2	30	12 88	0	0
2	122	135.776	144.4	42	2	2	30	12 88	0	0
3	123	134.738	144.4	43	2	2	30	12 68	0	0
4	124	133.915	144.5	44	6	2	30	12 68	0	0
5	125	132.944	144.0	45	-2	1	30	12 68	0	0
6	126	132.011	144.3	46	9	1	30	12 68	0	0
7	127	130.826	144.4	47	19	1	30	12 48	0	0
8	128	129.677	144.7	48	-21	1	30	12 48	0	0
9	129	128.952	144.3	49	3	3	30	12 48	1	0
10	131	126.944	144.3	50	6	1	30	12 48	0	0
11	132	125.945	144.4	51	3	2	30	12 48	0	0
12	133	125.113	144.3	52	-2	2	30	12 48	0	0
13	134	123.925	144.2	53	4	2	30	12 48	0	0
14	136	121.938	144.5	54	4	2	30	12 48	0	0
15	137	120.659	144.8	55	-17	2	30	12 48	0	0
16	138	119.876	144.8	56	0	1	30	12 48	0	0
17	139	118.891	144.8	57	0	2	30	12 48	0	0
18	140	117.724	144.7	58	6	2	30	12 48	0	0
19	141	116.867	144.7	59	-2	2	30	12 48	0	0
20	143	194.494	145.6	60	-4	2	30	12 48	0	0

FIELD DATA TABLE

SHOT NUMBER 2 SHOT POINT 11 TEAM 6
 SHOT TIME: 309: 7: 2: 0.009

LOC	DIST(KM)	AZIM	UNIT	CHRON	CHAN	C1	C2	C3	TAPE	GRADE
1	203	54.976	142.3	101	9		30	12 48	1	0
2	204	53.968	142.4	102	2	1	30	12 48	0	0
3	205	52.957	142.5	103	--		30	12 48	3	0
4	206	51.941	142.6	104	-3	1	30	12 48	0	0
5	207	50.938	142.7	105	5	1	30	12 48	0	0
6	208	49.934	142.9	106	-5	1	30	12 48	0	0
7	209	48.923	143.1	107	-8	1	30	12 48	0	0
8	210	47.923	143.2	108	5	1	30	12 48	0	0
9	211	46.905	143.3	109	1	1	30	12 48	0	0
10	213	44.922	143.7	110	6	1	30	12 48	0	0
11	214	43.892	143.9	111	17	1	30	12 48	0	0
12	215	42.873	144.1	112	-6	1	30	12 48	0	0
13	216	41.870	144.3	113	4	1	30	12 48	0	0
14	217	40.855	144.5	114	0	1	30	12 48	0	0
15	218	39.841	144.7	115	0	1	30	12 68	0	0
16	219	38.832	144.9	116	0	1	30	12 68	0	0
17	220	37.845	145.2	117	1	1	30	12 68	2	0
18	221	36.867	145.4	118	-3	1	30	12 88	0	0
19	222	36.094	145.5	119	2	1	30	12 88	0	0
20	11	0.000	180.0	120	--		30	12 88	0	3

FIELD DATA TABLE

SHOT NUMBER 2 SHOT POINT 11 TEAM 4
 SHOT TIME: 309: 7: 2: 0.009

LOC	DIST(KM)	AZIM	UNIT	CHRON	CHAN	C1	C2	C3	TAPE	GRADE
1	182	76.257	140.5	61	10	1	30	12 68	0	0
2	183	75.252	140.6	62	9	1	30	12 68	0	0
3	184	73.982	140.7	63	10	1	30	12 68	0	0
4	185	73.205	140.7	64	5	1	30	12 48	0	0
5	186	72.180	140.8	65	-24	1	30	12 48	0	0
6	187	71.163	140.8	66	6	1	30	12 48	0	0
7	188	70.164	140.9	67	-9	1	30	12 48	0	0
8	189	69.144	141.0	68	-10	2	30	12 48	0	0
9	190	68.140	141.1	69	5	2	30	12 48	0	0
10	191	67.143	141.1	70	11	2	30	12 48	0	0
11	192	66.110	141.2	71	-11	2	30	12 48	0	0
12	193	65.093	141.3	72	-9	2	30	12 48	0	0
13	194	64.116	141.4	73	6	2	30	12 48	0	0
14	195	63.113	141.5	74	2	2	30	12 48	0	0
15	196	62.082	141.5	75	10	2	30	12 48	0	0
16	197	61.065	141.6	76	32	1	30	12 48	0	0
17	198	60.011	141.7	77	6	2	30	12 48	0	0
18	199	59.009	141.8	78	15	2	30	12 48	0	0
19	200	58.000	141.9	79	-11	1	30	12 48	0	0
20	201	56.994	142.0	80	-3	2	30	12 48	0	0

FIELD DATA TABLE

SHOT NUMBER 3 SHOT POINT 13 TEAM 3
 SHOT TIME: 309: 7: 4: 0.017

LOC	DIST(KM)	AZIM	UNIT	CHRON	CHAN	C1	C2	C3	TAPE	GRADE
1	78.485	327.5	1	2	2	30	12	48	0	0
2	143	79.572	2	-9	2	30	12	48	0	0
3	144	80.661	3	6	2	30	12	48	0	0
4	145	81.633	4	-30	2	30	12	68	0	0
5	146	82.654	5	7	2	30	12	68	0	0
6	147	83.647	6	2	2	30	12	68	0	0
7	148	84.657	7	-13	2	30	12	88	0	0
8	169	105.756	8	-15	2	30	12	68	3	3
9	170	106.728	9	19	2	30	12	68	0	0
10	171	107.718	10	30	2	30	12	68	0	0
11	172	108.769	11	-11	2	30	12	48	0	0
12	173	109.722	12	0	2	30	12	48	0	0
13	174	110.722	13	-5	2	30	12	48	0	0
14	175	111.785	14	4	2	30	12	48	0	0
15	176	112.791	15	1	2	30	12	68	0	0
16	177	113.765	16	8	2	30	12	68	0	0
17	178	114.791	17	5	2	30	12	68	0	0
18	179	115.801	18	-9	2	30	12	88	0	0
19	180	116.795	19	-9	2	30	12	88	3	3
20	181	117.729	20	0	2	30	12	88	0	0

FIELD DATA TABLE

SHOT NUMBER 3 SHOT POINT 13 TEAM 1
 SHOT TIME: 309: 7: 4: 0.017

LOC	DIST(KM)	AZIM	UNIT	CHRON	CHAN	C1	C2	C3	TAPE	GRADE
1	121	58.102	41	3	2	30	12	88	0	0
2	122	58.807	42	2	2	30	12	88	0	0
3	123	59.840	43	2	2	30	12	68	0	0
4	124	60.659	44	6	2	30	12	68	0	0
5	125	61.696	45	-2	2	30	12	68	0	0
6	126	62.585	46	9	1	30	12	68	0	0
7	127	63.752	47	19	2	30	12	48	0	0
8	128	64.859	48	-21	2	30	12	48	0	0
9	129	65.628	49	3	3	30	12	48	2	2
10	131	67.636	50	6	1	30	12	48	0	0
11	132	68.617	51	3	2	30	12	48	0	0
12	133	69.467	52	-2	2	30	12	48	0	0
13	134	70.659	53	4	2	30	12	48	0	0
14	136	72.613	54	4	2	30	12	48	0	0
15	137	73.864	55	-17	2	30	12	48	0	0
16	138	74.643	56	0	2	30	12	48	0	0
17	139	75.627	57	0	2	30	12	48	0	0
18	140	76.803	58	6	2	30	12	48	0	0
19	141	77.660	59	-2	2	30	12	48	0	0
20	13	0.000	60	-4	2	30	12	48	3	3

FIELD DATA TABLE

SHOT NUMBER 3 SHOT POINT 13 TEAM 4
 SHOT TIME: 309: 7: 4: 0.017

LOC	DIST(KM)	AZIM	UNIT	CHRON	CHAN	C1	C2	C3	TAPE	GRADE
1	182	118.719	61	10	2	30	12	68	0	0
2	183	119.702	62	9	2	30	12	68	0	0
3	184	120.948	63	10	2	30	12	68	0	0
4	185	121.709	64	5	2	30	12	48	0	0
5	186	122.710	65	-24	2	30	12	48	0	0
6	187	123.710	66	6	2	30	12	48	0	0
7	188	124.688	67	-9	2	30	12	48	0	0
8	189	125.690	68	-10	2	30	12	48	0	0
9	190	126.676	69	5	2	30	12	48	0	0
10	191	127.655	70	11	2	30	12	48	0	0
11	192	128.671	71	-11	2	30	12	48	0	0
12	193	129.671	72	-9	2	30	12	48	0	0
13	194	130.631	73	6	2	30	12	48	0	0
14	195	131.620	74	2	2	30	12	48	0	0
15	196	132.636	75	10	2	30	12	48	0	0
16	197	133.637	76	32	2	30	12	48	0	0
17	198	134.675	77	6	2	30	12	48	0	0
18	199	135.663	78	15	2	30	12	48	0	0
19	200	136.661	79	-11	2	30	12	48	0	0
20	201	137.653	80	3	2	30	12	48	0	0

FIELD DATA TABLE

SHOT NUMBER 3 SHOT POINT 13 TEAM 2
 SHOT TIME: 309: 7: 4: 0.017

LOC	DIST(KM)	AZIM	UNIT	CHRON	CHAN	C1	C2	C3	TAPE	GRADE
1	120	57.778	29.0	21	1	30	12	88	0	0
2	119	56.627	328.9	22	5	2	30	12	48	0
3	118	55.673	328.4	23	3	1	30	12	68	0
4	117	54.644	328.2	24	-7	2	30	12	68	0
5	116	53.559	328.2	25	-11	2	30	12	68	4
6	115	52.595	327.8	26	7	2	30	12	88	0
7	114	51.671	328.0	27	0	2	30	12	88	0
8	113	50.053	328.7	28	-28	2	30	12	68	0
9	112	47.807	330.3	29	6	2	30	12	68	0
10	111	45.945	330.5	30	3	1	30	12	48	0
11	110	44.557	329.5	31	57	1	30	12	48	0
12	109	43.175	328.4	32	6	1	30	12	48	3
13	108	40.877	329.4	33	11	1	30	12	48	0
14	107	38.675	330.2	34	4	1	30	12	48	0
15	106	36.607	330.8	35	-23	1	30	12	48	0
16	105	35.083	329.9	36	-2	1	30	12	48	0
17	104	33.563	328.3	37	2	1	30	12	48	2
18	103	31.340	329.2	38	3	2	30	12	48	0
19	102	29.145	330.4	39	3	1	30	12	48	0
20	101	26.951	331.6	40	2	1	30	12	48	0

FIELD DATA TABLE

SHOT NUMBER 4 SHOT POINT 9 TEAM 1
SHOT TIME: 309: 7: 6: 0.013

LOC	DIST(KM)	AZIM	UNIT	CHRON	CHAN	C1	C2	C3	TAPE	GRADE
1	142	38.368	1	2	1	30	12	48	0	0
2	143	37.334	2	-9	1	30	12	48	0	0
3	144	36.266	3	6	1	30	12	48	0	0
4	145	35.419	4	-30	2	30	12	68	0	0
5	146	34.385	5	7	1	30	12	68	0	0
6	147	33.372	6	2	2	30	12	68	1	1
7	148	32.352	7	-13	1	30	12	88	0	0
8	169	10.959	8	-15	3	30	12	68	2	2
9	170	9.985	9	19	3	30	12	68	0	0
10	171	8.992	10	30	3	30	12	68	0	0
11	172	7.942	11	-11	3	30	12	48	0	0
12	173	6.991	12	0	3	30	12	48	0	0
13	174	6.007	13	-5	3	30	12	48	0	0
14	175	4.970	14	4	3	30	12	48	0	0
15	176	3.974	15	1	3	30	12	68	0	0
16	177	3.028	16	8	3	30	12	68	0	0
17	178	2.064	17	5	3	30	12	68	0	0
18	179	1.002	18	-9	3	30	12	88	0	0
19	180	0.142	19	-9	3	30	12	88	3	3
20	181	1.070	20	0	3	30	12	88	0	0

FIELD DATA TABLE

SHOT NUMBER 3 SHOT POINT 13 TEAM 5
SHOT TIME: 309: 7: 4: 0.017

LOC	DIST(KM)	AZIM	UNIT	CHRON	CHAN	C1	C2	C3	TAPE	GRADE
1	149	85.527	81	11	2	30	12	88	0	0
2	150	86.723	82	-10	2	30	12	88	0	0
3	151	87.736	83	16	2	30	12	68	0	0
4	152	88.752	84	-13	2	30	12	48	0	0
5	153	89.677	85	-18	2	30	12	48	0	0
6	154	90.659	86	0	2	30	12	48	0	0
7	156	92.667	87	-12	1	30	12	48	0	0
8	157	93.668	88	21	2	30	12	48	0	0
9	158	94.661	89	0	1	30	12	48	0	0
10	155	91.651	90	--	2	30	12	48	0	0
11	159	95.696	91	5	1	30	12	48	0	0
12	160	96.730	92	-3	2	30	12	48	0	0
13	161	97.687	93	-7	2	30	12	48	0	0
14	162	98.697	94	18	2	30	12	48	0	0
15	163	99.703	95	2	2	30	12	48	0	0
16	164	100.733	96	-34	2	30	12	68	0	0
17	165	101.750	97	5	2	30	12	68	0	0
18	166	102.701	98	-28	2	30	12	88	0	0
19	167	103.791	99	14	2	30	12	88	0	0
20	168	104.778	100	9	2	30	12	88	3	3

FIELD DATA TABLE

SHOT NUMBER 4 SHOT POINT 9 TEAM 2
SHOT TIME: 309: 7: 6: 0.013

LOC	DIST(KM)	AZIM	UNIT	CHRON	CHAN	C1	C2	C3	TAPE	GRADE
1	120	58.940	21	1	1	30	12	88	0	0
2	119	60.095	22	5	2	30	12	48	0	0
3	118	61.067	23	3	2	30	12	68	0	0
4	117	62.103	24	-7	2	30	12	68	0	0
5	116	63.188	25	-12	2	30	12	68	4	4
6	115	64.171	26	7	2	30	12	88	0	0
7	114	65.082	27	0	2	30	12	88	0	0
8	113	66.672	28	-28	1	30	12	68	0	0
9	112	68.907	29	6	2	30	12	68	0	0
10	111	70.772	30	3	3	30	12	48	2	2
11	110	72.153	31	57	1	30	12	48	0	0
12	109	73.555	32	6	6	30	12	48	3	3
13	108	75.834	33	11	2	30	12	48	0	0
14	107	78.037	34	4	2	30	12	48	0	0
15	106	80.112	35	-23	2	30	12	48	0	0
16	105	81.627	36	-2	2	30	12	48	0	0
17	104	83.162	37	2	2	30	12	48	2	2
18	103	85.372	38	3	2	30	12	48	0	0
19	102	87.568	39	3	2	30	12	48	0	0
20	101	89.778	40	2	2	30	12	48	0	0

FIELD DATA TABLE

SHOT NUMBER 3 SHOT POINT 13 TEAM 6
SHOT TIME: 309: 7: 4: 0.017

LOC	DIST(KM)	AZIM	UNIT	CHRON	CHAN	C1	C2	C3	TAPE	GRADE
1	203	139.645	101	9	2	30	12	48	1	1
2	204	140.642	102	2	2	30	12	48	0	0
3	205	141.642	103	--	2	30	12	48	3	3
4	206	142.646	104	-3	2	30	12	48	0	0
5	207	143.639	105	5	2	30	12	48	0	0
6	208	144.633	106	-5	2	30	12	48	0	0
7	209	145.633	107	-8	2	30	12	48	0	0
8	210	146.624	108	5	2	30	12	48	0	0
9	211	147.634	109	1	2	30	12	48	0	0
10	213	149.602	110	6	2	30	12	48	0	0
11	214	150.626	111	17	2	30	12	48	0	0
12	215	151.640	112	-6	2	30	12	48	0	0
13	216	152.636	113	4	2	30	12	48	0	0
14	217	153.648	114	0	2	30	12	48	0	0
15	218	154.659	115	0	2	30	12	68	0	0
16	219	155.665	116	0	2	30	12	68	0	0
17	220	156.650	117	1	1	30	12	68	2	2
18	221	157.627	118	-3	2	30	12	88	0	0
19	222	158.400	119	2	2	30	12	88	0	0
20	11	194.494	120	0	0	30	12	88	3	3

FIELD DATA TABLE

SHOT NUMBER 4 SHOT POINT 9 TEAM 5
 SHOT TIME: 309: 7: 6: 0.013

LOC	DIST(KM)	AZIM	UNIT	CHRON	CHAN	C1	C2	C3	TAPE	GRADE
1	149	31.657	81	11	2	30	12	88	0	0
2	150	30.361	82	-10	2	30	12	88	0	0
3	151	29.232	83	16	2	30	12	68	0	0
4	152	28.233	84	-13	1	30	12	48	0	0
5	153	27.342	85	-18	2	30	12	48	0	0
6	154	26.453	86	0	2	30	12	48	0	0
7	156	24.318	87	-12	1	30	12	48	0	0
8	157	23.309	88	21	1	30	12	48	0	0
9	158	22.297	89	0	1	30	12	48	0	0
10	155	25.472	90	--	1	30	12	48	0	0
11	159	21.222	91	5	1	30	12	48	0	0
12	160	20.137	92	-3	1	30	12	48	0	0
13	161	19.192	93	-7	1	30	12	48	0	0
14	162	18.162	94	18	1	30	12	48	0	0
15	163	17.126	95	2	1	30	12	48	0	0
16	164	16.047	96	-34	1	30	12	68	0	0
17	165	15.002	97	5	1	30	12	68	0	0
18	166	14.028	98	-28	1	30	12	88	0	0
19	167	12.927	99	14	1	30	12	88	0	0
20	168	11.939	100	9	1	30	12	88	0	3

FIELD DATA TABLE

SHOT NUMBER 4 SHOT POINT 9 TEAM 3
 SHOT TIME: 309: 7: 6: 0.013

LOC	DIST(KM)	AZIM	UNIT	CHRON	CHAN	C1	C2	C3	TAPE	GRADE
1	121	58.624	41	3	2	30	12	88	0	0
2	122	57.917	42	2	2	30	12	88	0	0
3	123	56.888	43	2	2	30	12	68	0	0
4	124	56.073	44	6	2	30	12	68	0	0
5	125	55.015	45	-2	2	30	12	68	0	0
6	126	54.138	46	9	1	30	12	68	0	0
7	127	52.984	47	19	2	30	12	48	0	0
8	128	51.924	48	-21	1	30	12	48	0	0
9	129	51.110	49	3	1	30	12	48	0	0
10	131	49.107	50	6	1	30	12	48	0	0
11	132	48.147	51	3	2	30	12	48	0	0
12	133	47.280	52	-2	1	30	12	48	0	0
13	134	46.089	53	4	1	30	12	48	0	0
14	136	44.180	54	4	1	30	12	48	0	0
15	137	43.000	55	-17	2	30	12	48	0	0
16	138	42.239	56	0	2	30	12	48	0	0
17	139	41.268	57	0	2	30	12	48	0	0
18	140	40.071	58	6	1	30	12	48	0	0
19	141	39.220	59	-2	1	30	12	48	0	0
20	143	116.710	60	-4	1	30	12	48	0	3

FIELD DATA TABLE

SHOT NUMBER 4 SHOT POINT 9 TEAM 6
 SHOT TIME: 309: 7: 6: 0.013

LOC	DIST(KM)	AZIM	UNIT	CHRON	CHAN	C1	C2	C3	TAPE	GRADE
1	203	23.453	101	9	1	30	12	48	1	1
2	204	24.465	102	2	1	30	12	48	0	0
3	205	25.481	103	--	1	30	12	48	3	3
4	206	26.505	104	-3	1	30	12	48	0	0
5	207	27.516	105	5	1	30	12	48	0	0
6	208	28.528	106	-5	1	30	12	48	0	0
7	209	29.549	107	-8	1	30	12	48	0	0
8	210	30.557	108	5	1	30	12	48	0	0
9	211	31.581	109	1	2	30	12	48	0	0
10	213	33.586	110	6	1	30	12	48	0	0
11	214	34.623	111	17	1	30	12	48	0	0
12	215	35.651	112	-6	1	30	12	48	0	0
13	216	36.667	113	4	2	30	12	48	0	0
14	217	37.693	114	0	2	30	12	48	0	0
15	218	38.717	115	0	1	30	12	68	0	0
16	219	39.738	116	0	2	30	12	68	0	0
17	220	40.739	117	1	1	30	12	68	2	2
18	221	41.727	118	-3	1	30	12	88	0	0
19	222	42.503	119	2	1	30	12	88	0	0
20	11	78.326	120	--	1	30	12	88	0	3

FIELD DATA TABLE

SHOT NUMBER 4 SHOT POINT 9 TEAM 4
 SHOT TIME: 309: 7: 6: 0.013

LOC	DIST(KM)	AZIM	UNIT	CHRON	CHAN	C1	C2	C3	TAPE	GRADE
1	182	2.084	61	10	3	30	12	68	0	0
2	183	3.091	62	9	3	30	12	68	0	0
3	184	4.364	63	10	3	30	12	68	0	0
4	185	5.143	64	5	3	30	12	48	0	0
5	186	6.175	65	-24	3	30	12	48	0	0
6	187	7.192	66	6	3	30	12	48	0	0
7	188	8.195	67	-9	3	30	12	48	0	0
8	189	9.219	68	-10	3	30	12	48	0	0
9	190	10.227	69	5	1	30	12	48	0	0
10	191	11.228	70	11	1	30	12	48	0	0
11	192	12.264	71	-11	1	30	12	48	0	0
12	193	13.285	72	-9	1	30	12	48	0	0
13	194	14.267	73	6	1	30	12	48	0	0
14	195	15.274	74	2	2	30	12	48	0	0
15	196	16.310	75	10	2	30	12	48	0	0
16	197	17.331	76	32	1	30	12	48	0	0
17	198	18.330	77	6	2	30	12	48	0	0
18	199	19.337	78	15	1	30	12	48	0	0
19	200	20.410	79	-11	2	30	12	48	0	0
20	201	21.421	80	3	1	30	12	48	0	0

FIELD DATA TABLE

SHOT NUMBER 5 SHOT POINT 9 TEAM 3
SHOT TIME: 309: 7:30: 0.014

LOC	DIST(KM)	AZIM	UNIT	CHRON	CHAN	C1	C2	C3	TAPE	GRADE
1	121	58.624	41	3	2	30	12	88	0	0
2	122	57.917	42	2	2	30	12	88	0	0
3	123	56.888	43	2	2	30	12	68	0	0
4	124	56.073	44	6	2	30	12	68	0	0
5	125	55.015	45	-2	2	30	12	68	0	0
6	126	54.138	46	10	2	30	12	68	0	0
7	127	52.984	47	20	2	30	12	48	0	0
8	128	51.924	48	-22	2	30	12	48	0	0
9	129	51.110	49	3	2	30	12	48	0	0
10	131	49.107	50	6	2	30	12	48	0	0
11	132	48.147	51	3	2	30	12	48	0	0
12	133	47.280	52	-2	2	30	12	48	0	0
13	134	46.089	53	4	1	30	12	48	0	0
14	136	44.180	54	4	2	30	12	48	0	0
15	137	43.000	55	-17	2	30	12	48	0	0
16	138	42.239	56	0	2	30	12	48	0	0
17	139	41.268	57	0	2	30	12	48	0	0
18	140	40.071	58	6	2	30	12	48	0	0
19	141	39.220	59	-2	2	30	12	48	0	0
20	143	116.710	60	-4	2	30	12	48	0	3

FIELD DATA TABLE

SHOT NUMBER 5 SHOT POINT 9 TEAM 1
SHOT TIME: 309: 7:30: 0.014

LOC	DIST(KM)	AZIM	UNIT	CHRON	CHAN	C1	C2	C3	TAPE	GRADE
1	142	38.368	21	1	2	30	12	48	0	0
2	143	37.334	22	-9	2	30	12	48	0	0
3	144	36.266	23	6	2	30	12	48	0	0
4	145	35.419	24	-31	2	30	12	68	0	0
5	146	34.385	25	7	2	30	12	68	0	0
6	147	33.372	26	2	2	30	12	68	1	0
7	148	32.392	27	-13	2	30	12	88	0	0
8	169	10.959	28	-15	1	30	12	68	0	0
9	170	9.985	29	20	1	30	12	68	0	0
10	171	8.992	30	31	1	30	12	68	0	0
11	172	7.942	31	-11	1	30	12	48	0	0
12	173	6.991	32	0	1	30	12	48	0	0
13	174	6.007	33	-5	3	30	12	48	0	0
14	175	4.970	34	5	3	30	12	48	0	0
15	176	3.974	35	1	3	30	12	68	0	0
16	177	3.028	36	8	3	30	12	68	0	0
17	178	2.064	37	5	3	30	12	68	0	0
18	179	1.002	38	-9	1	30	12	88	6	0
19	180	0.142	39	-9	3	30	12	88	0	0
20	181	1.070	40	0	2	30	12	88	0	0

FIELD DATA TABLE

SHOT NUMBER 5 SHOT POINT 9 TEAM 4
SHOT TIME: 309: 7:30: 0.014

LOC	DIST(KM)	AZIM	UNIT	CHRON	CHAN	C1	C2	C3	TAPE	GRADE
1	182	2.084	61	10	3	30	12	68	0	0
2	183	3.091	62	9	1	30	12	68	6	0
3	184	4.364	63	10	1	30	12	68	0	0
4	185	5.143	64	5	3	30	12	48	0	0
5	186	6.175	65	-24	1	30	12	48	0	0
6	187	7.192	66	6	1	30	12	48	0	0
7	188	8.195	67	-9	1	30	12	48	0	0
8	189	9.219	68	-10	1	30	12	48	0	0
9	190	10.227	69	5	1	30	12	48	0	0
10	191	11.228	70	11	1	30	12	48	0	0
11	192	12.264	71	-11	2	30	12	48	0	0
12	193	13.285	72	-9	2	30	12	48	0	0
13	194	14.267	73	6	2	30	12	48	0	0
14	195	15.274	74	2	2	30	12	48	0	0
15	196	16.310	75	10	2	30	12	48	0	0
16	197	17.331	76	32	2	30	12	48	0	0
17	198	18.390	77	6	2	30	12	48	0	0
18	199	19.397	78	15	2	30	12	48	0	0
19	200	20.410	79	-11	2	30	12	48	0	0
20	201	21.421	80	3	2	30	12	48	0	0

FIELD DATA TABLE

SHOT NUMBER 5 SHOT POINT 9 TEAM 2
SHOT TIME: 309: 7:30: 0.014

LOC	DIST(KM)	AZIM	UNIT	CHRON	CHAN	C1	C2	C3	TAPE	GRADE
1	120	58.940	21	1	2	30	12	88	0	0
2	119	60.095	22	5	2	30	12	48	0	0
3	118	61.067	23	3	2	30	12	68	0	0
4	117	62.103	24	-7	2	30	12	68	0	0
5	116	63.188	25	-12	2	30	12	68	2	0
6	115	64.171	26	8	2	30	12	88	0	0
7	114	65.082	27	0	2	30	12	88	0	0
8	113	66.672	28	-29	2	30	12	68	0	0
9	112	68.907	29	6	3	30	12	68	2	0
10	111	70.772	30	3	3	30	12	48	2	0
11	110	72.153	31	58	1	30	12	48	3	0
12	109	73.555	32	7	1	30	12	48	0	0
13	108	75.834	33	11	2	30	12	48	0	0
14	107	78.037	34	4	2	30	12	48	0	0
15	106	80.112	35	-23	2	30	12	48	0	0
16	105	81.627	36	-2	2	30	12	48	0	0
17	104	83.162	37	2	2	30	12	48	0	0
18	103	85.372	38	3	2	30	12	48	0	0
19	102	87.568	39	3	2	30	12	48	0	0
20	101	89.778	40	2	2	30	12	48	0	0

FIELD DATA TABLE

SHOT NUMBER 6 SHOT POINT 17 TEAM 1
 SHOT TIME: 309: 9: 0: 0.011

LOC	DIST(KM)	AZIM	UNIT	CHRON	CHAN	C1	C2	C3	TAPE	GRADE
1	142	20.405	324.5	1	2	1	30	12	48	0
2	143	21.514	323.6	2	-10	1	30	12	48	0
3	144	22.607	323.5	3	7	1	30	12	48	0
4	145	23.635	321.8	4	-34	1	30	12	68	0
5	146	24.638	322.4	5	8	1	30	12	68	0
6	147	25.614	323.0	6	3	3	30	12	68	1
7	148	26.628	322.9	7	-14	1	30	12	88	0
8	169	47.647	330.3	8	-17	1	30	12	68	0
9	170	48.621	330.4	9	22	2	30	12	68	0
10	171	49.614	330.5	10	34	2	30	12	68	0
11	172	50.668	330.7	11	-12	2	30	12	48	0
12	173	51.623	330.8	12	0	2	30	12	48	0
13	174	52.626	331.0	13	-5	1	30	12	48	0
14	175	53.694	331.2	14	5	2	30	12	68	0
15	176	54.700	331.2	15	1	1	30	12	68	0
16	177	55.675	331.2	16	9	1	30	12	68	0
17	178	56.701	331.2	17	6	2	30	12	68	0
18	179	57.703	330.9	18	-10	2	30	12	88	0
19	180	58.688	330.3	19	-10	2	30	12	88	0
20	181	59.620	330.1	20	0	2	30	12	88	0

FIELD DATA TABLE

SHOT NUMBER 5 SHOT POINT 9 TEAM 5
 SHOT TIME: 309: 7:30: 0.014

LOC	DIST(KM)	AZIM	UNIT	CHRON	CHAN	C1	C2	C3	TAPE	GRADE
1	149	31.657	157.9	81	12	2	30	12	88	0
2	150	30.361	157.1	82	-10	2	30	12	88	0
3	151	29.232	156.0	83	16	2	30	12	68	0
4	152	28.233	156.3	84	-14	2	30	12	48	0
5	153	27.342	156.9	85	-19	2	30	12	48	0
6	154	26.453	158.2	86	0	2	30	12	48	0
7	156	24.318	157.0	87	-12	1	30	12	48	0
8	157	23.309	157.1	88	21	2	30	12	48	0
9	158	22.297	157.1	89	0	2	30	12	48	0
10	155	25.472	158.5	90	--	2	30	12	48	0
11	159	21.222	156.6	91	5	1	30	12	48	0
12	160	20.137	155.9	92	-3	2	30	12	48	0
13	161	19.192	156.3	93	-7	1	30	12	48	0
14	162	18.162	156.1	94	18	1	30	12	48	0
15	163	17.126	155.6	95	2	1	30	12	48	0
16	164	16.047	154.3	96	-35	1	30	12	68	0
17	165	15.002	153.4	97	5	1	30	12	68	0
18	166	14.028	152.2	98	-28	1	30	12	88	0
19	167	12.927	151.2	99	15	1	30	12	88	0
20	168	11.939	151.3	100	10	1	30	12	88	3

FIELD DATA TABLE

SHOT NUMBER 6 SHOT POINT 17 TEAM 2
 SHOT TIME: 309: 9: 0: 0.011

LOC	DIST(KM)	AZIM	UNIT	CHRON	CHAN	C1	C2	C3	TAPE	GRADE
1	120	0.401	117.0	21	1	3	30	12	88	0
2	119	1.496	145.0	22	6	3	30	12	48	6
3	118	2.486	158.7	23	3	3	30	12	68	6
4	117	3.531	158.5	24	-8	3	30	12	68	0
5	116	4.606	156.4	25	-13	3	30	12	68	0
6	115	5.617	158.6	26	8	1	30	12	88	6
7	114	6.498	155.3	27	0	1	30	12	88	6
8	113	8.067	149.6	28	-32	3	30	12	68	0
9	112	10.400	141.9	29	6	3	30	12	68	0
10	111	12.268	142.3	30	3	3	30	12	48	2
11	110	13.575	146.4	31	64	3	30	12	48	0
12	109	14.949	150.0	32	7	3	30	12	48	0
13	108	17.248	147.4	33	12	3	30	12	48	0
14	107	19.479	145.8	34	5	3	30	12	48	0
15	106	21.568	145.4	35	-25	3	30	12	48	0
16	105	23.051	147.1	36	-2	3	30	12	48	0
17	104	24.560	149.3	37	2	3	30	12	48	2
18	103	26.781	148.2	38	3	3	30	12	48	0
19	102	28.996	147.1	39	3	3	30	12	48	0
20	101	31.228	146.2	40	2	3	30	12	48	0

FIELD DATA TABLE

SHOT NUMBER 5 SHOT POINT 9 TEAM 6
 SHOT TIME: 309: 7:30: 0.014

LOC	DIST(KM)	AZIM	UNIT	CHRON	CHAN	C1	C2	C3	TAPE	GRADE
1	203	23.453	316.2	101	9	9	30	12	48	1
2	204	24.465	316.2	102	2	2	30	12	48	0
3	205	25.481	316.2	103	--	2	30	12	48	3
4	206	26.505	316.2	104	-3	2	30	12	48	0
5	207	27.516	316.2	105	5	2	30	12	48	0
6	208	28.528	316.2	106	-5	2	30	12	48	0
7	209	29.549	316.1	107	-8	2	30	12	48	0
8	210	30.557	316.1	108	5	2	30	12	48	0
9	211	31.581	316.2	109	1	2	30	12	48	0
10	213	33.586	316.1	110	6	2	30	12	48	0
11	214	34.623	316.2	111	17	2	30	12	48	0
12	215	35.651	316.2	112	-6	2	30	12	48	0
13	216	36.667	316.1	113	4	2	30	12	48	0
14	217	37.693	316.2	114	0	1	30	12	48	0
15	218	38.717	316.2	115	0	2	30	12	68	0
16	219	39.738	316.2	116	0	2	30	12	68	0
17	220	40.739	316.2	117	1	1	30	12	68	2
18	221	41.727	316.2	118	-3	2	30	12	88	0
19	222	42.503	316.3	119	2	2	30	12	88	0
20	11	78.326	320.7	120	--	2	30	12	88	3

FIELD DATA TABLE

SHOT NUMBER 6 SHOT POINT 17 TEAM 5
SHOT TIME: 309: 9: 0: 0.011

LOC	DIST(KM)	AZIM	UNIT	CHRON	CHAN	C1	C2	C3	TAPE	GRADE
1	27.545	321.7	81	12	1	30	12	88	0	0
2	28.691	323.2	82	-11	1	30	12	88	0	0
3	29.660	324.8	83	17	1	30	12	68	0	0
4	30.676	324.9	84	-14	1	30	12	48	0	0
5	31.607	324.7	85	-20	1	30	12	48	0	0
6	32.607	324.0	86	0	1	30	12	48	0	0
7	34.577	325.7	87	-13	1	30	12	48	0	0
8	35.574	325.9	88	22	1	30	12	48	0	0
9	36.561	326.3	89	0	1	30	12	48	0	0
10	33.595	324.2	90	--	1	30	12	48	0	0
11	37.589	326.8	91	6	1	30	12	48	0	0
12	38.616	327.5	92	-3	2	30	12	48	0	0
13	39.572	327.5	93	-7	1	30	12	48	0	0
14	40.580	327.8	94	19	1	30	12	48	0	0
15	41.584	328.2	95	2	1	30	12	48	0	0
16	42.614	328.9	96	-37	1	30	12	68	0	0
17	43.633	329.4	97	5	1	30	12	68	0	0
18	44.588	329.8	98	-30	1	30	12	88	0	0
19	45.680	330.2	99	15	1	30	12	88	0	0
20	46.669	330.2	100	10	1	30	12	88	0	3

FIELD DATA TABLE

SHOT NUMBER 6 SHOT POINT 17 TEAM 3
SHOT TIME: 309: 9: 0: 0.011

LOC	DIST(KM)	AZIM	UNIT	CHRON	CHAN	C1	C2	C3	TAPE	GRADE
1	0.042	214.3	41	4	3	30	12	88	0	0
2	0.688	331.1	42	2	3	30	12	88	0	0
3	1.722	326.4	43	2	3	30	12	68	0	0
4	2.545	325.0	44	7	3	30	12	68	0	0
5	3.644	340.0	45	-2	3	30	12	68	0	0
6	4.467	330.0	46	11	3	30	12	68	0	0
7	5.636	326.5	47	22	3	30	12	48	0	0
8	6.810	319.9	48	-23	3	30	12	48	0	0
9	7.512	326.8	49	3	3	30	12	48	0	0
10	9.521	326.8	50	7	3	30	12	48	0	0
11	10.515	325.1	51	4	3	30	12	48	0	0
12	11.353	326.8	52	-3	3	30	12	48	0	0
13	12.544	327.0	53	5	3	30	12	48	0	0
14	14.522	324.7	54	4	1	30	12	48	0	0
15	15.819	322.4	55	-19	1	30	12	48	0	0
16	16.605	322.2	56	0	1	30	12	48	0	0
17	17.591	322.3	57	0	1	30	12	48	0	0
18	18.744	323.3	58	7	1	30	12	48	0	0
19	19.600	323.5	59	-3	1	30	12	48	0	0
20	58.119	148.6	60	-4	1	30	12	48	0	3

FIELD DATA TABLE

SHOT NUMBER 6 SHOT POINT 17 TEAM 6
SHOT TIME: 309: 9: 0: 0.011

LOC	DIST(KM)	AZIM	UNIT	CHRON	CHAN	C1	C2	C3	TAPE	GRADE
1	81.551	326.4	101	10	1	30	12	48	1	1
2	82.551	326.3	102	2	1	30	12	48	0	0
3	83.554	326.2	103	--	--	30	12	48	3	3
4	84.562	326.1	104	-3	1	30	12	48	0	0
5	85.558	326.0	105	6	1	30	12	48	0	0
6	86.555	325.8	106	-5	1	30	12	48	0	0
7	87.559	325.7	107	-8	1	30	12	48	0	0
8	88.554	325.6	108	6	1	30	12	48	0	0
9	89.568	325.5	109	1	1	30	12	48	0	0
10	91.543	325.3	110	7	1	30	12	48	0	0
11	92.571	325.2	111	19	1	30	12	48	0	0
12	93.589	325.1	112	-7	1	30	12	48	0	0
13	94.590	325.0	113	5	1	30	12	48	0	0
14	95.605	324.9	114	0	1	30	12	48	0	0
15	96.619	324.8	115	0	1	30	12	68	0	0
16	97.630	324.8	116	0	1	30	12	68	0	0
17	98.619	324.7	117	1	1	30	12	68	2	2
18	99.599	324.6	118	-4	1	30	12	88	0	0
19	100.374	324.6	119	2	1	30	12	88	0	0
20	136.459	324.9	120	--	--	30	12	88	0	3

FIELD DATA TABLE

SHOT NUMBER 6 SHOT POINT 17 TEAM 4
SHOT TIME: 309: 9: 0: 0.011

LOC	DIST(KM)	AZIM	UNIT	CHRON	CHAN	C1	C2	C3	TAPE	GRADE
1	60.606	329.9	61	11	1	30	12	68	0	0
2	61.587	329.7	62	9	1	30	12	68	0	0
3	62.832	329.4	63	10	2	30	12	68	0	0
4	63.592	329.3	64	5	1	30	12	48	0	0
5	64.592	329.0	65	-25	3	30	12	48	0	0
6	65.590	328.9	66	6	2	30	12	48	0	0
7	66.569	328.7	67	-10	1	30	12	48	0	0
8	67.571	328.5	68	-10	1	30	12	48	0	0
9	68.537	328.3	69	6	1	30	12	48	0	0
10	69.537	328.1	70	12	1	30	12	48	0	0
11	70.554	328.0	71	-11	1	30	12	48	0	0
12	71.555	327.8	72	-10	2	30	12	48	0	0
13	72.517	327.7	73	6	2	30	12	48	0	0
14	73.507	327.5	74	2	1	30	12	48	0	0
15	74.524	327.4	75	10	1	30	12	48	0	0
16	75.528	327.2	76	34	1	30	12	48	0	0
17	76.568	327.1	77	6	1	30	12	48	0	0
18	77.559	326.9	78	16	1	30	12	48	0	0
19	78.558	326.8	79	-12	1	30	12	48	0	0
20	79.554	326.7	80	3	1	30	12	48	0	0

FIELD DATA TABLE

SHOT NUMBER 7 SHOT POINT 10 TEAM 3
 SHOT TIME: 309: 9: 2: 0.010

LOC	DIST(KM)	AZIM	UNIT	CHRON	CHAN	C1	C2	C3	TAPE	GRADE
1	121	100.271	41	4	1	30	12	88	2	0
2	122	99.573	42	2	1	30	12	88	0	0
3	123	98.536	43	2	2	30	12	68	0	0
4	124	97.712	44	7	1	30	12	68	0	0
5	125	96.748	45	-2	1	30	12	68	0	0
6	126	95.911	46	11	1	30	12	68	0	0
7	127	94.624	47	22	2	30	12	48	0	0
8	128	93.471	48	-24	1	30	12	48	0	0
9	129	92.751	49	4	1	30	12	48	0	0
10	131	90.744	50	7	1	30	12	48	0	0
11	132	89.743	51	4	1	30	12	48	0	0
12	133	88.913	52	-3	1	30	12	48	0	0
13	134	87.726	53	5	1	30	12	48	0	0
14	136	85.735	54	4	2	30	12	48	0	0
15	137	84.452	55	-19	2	30	12	48	0	0
16	138	83.669	56	0	2	30	12	48	0	0
17	139	82.684	57	0	2	30	12	48	0	0
18	140	81.518	58	7	1	30	12	48	0	0
19	141	80.662	59	-3	1	30	12	48	0	0
20	143	159.285	60	-4	1	30	12	48	3	0

SHOT NUMBER 7 SHOT POINT 10 TEAM 1
 SHOT TIME: 309: 9: 2: 0.010

LOC	DIST(KM)	AZIM	UNIT	CHRON	CHAN	C1	C2	C3	TAPE	GRADE
1	142	79.851	144.3	2	1	30	12	48	0	0
2	143	78.747	144.5	1	-10	2	30	12	48	0
3	144	77.655	144.6	3	7	1	30	12	48	0
4	145	76.660	145.1	4	-34	2	30	12	68	0
5	146	75.644	145.0	5	8	2	30	12	68	0
6	147	74.657	144.8	6	3	30	12	68	1	0
7	148	73.644	144.8	7	-14	2	30	12	88	0
8	169	53.050	139.2	8	-17	1	30	12	68	0
9	170	52.111	138.9	9	22	1	30	12	68	0
10	171	51.168	138.5	10	34	1	30	12	68	0
11	172	50.173	138.0	11	-12	1	30	12	48	0
12	173	49.251	137.8	12	0	1	30	12	48	0
13	174	48.323	137.2	13	-5	1	30	12	48	0
14	175	47.326	136.7	14	5	2	30	12	48	0
15	176	46.343	136.5	15	1	1	30	12	68	0
16	177	45.404	136.1	16	9	1	30	12	68	0
17	178	44.419	135.8	17	6	1	30	12	68	0
18	179	43.357	135.9	18	-10	2	30	12	88	0
19	180	42.268	136.3	19	-10	1	30	12	88	0
20	181	41.310	136.3	20	0	1	30	12	88	0

FIELD DATA TABLE

SHOT NUMBER 7 SHOT POINT 10 TEAM 4
 SHOT TIME: 309: 9: 2: 0.010

LOC	DIST(KM)	AZIM	UNIT	CHRON	CHAN	C1	C2	C3	TAPE	GRADE
1	182	40.294	136.3	61	11	1	30	12	68	0
2	183	39.286	136.3	62	9	1	30	12	68	0
3	184	38.013	136.3	63	10	1	30	12	68	0
4	185	37.233	136.3	64	5	1	30	12	48	0
5	186	36.202	136.3	65	-25	1	30	12	48	0
6	187	35.185	136.3	66	6	1	30	12	48	0
7	188	34.181	136.3	67	-10	1	30	12	48	0
8	189	33.158	136.3	68	-10	1	30	12	48	0
9	190	32.149	136.3	69	6	2	30	12	48	0
10	191	31.149	136.3	70	12	1	30	12	48	0
11	192	30.112	136.3	71	-11	1	30	12	48	0
12	193	29.091	136.3	72	-10	1	30	12	48	0
13	194	28.109	136.3	73	6	1	30	12	48	0
14	195	27.103	136.3	74	2	2	30	12	48	0
15	196	26.066	136.3	75	10	1	30	12	48	0
16	197	25.045	136.3	76	34	1	30	12	48	0
17	198	23.986	136.4	77	6	2	30	12	48	0
18	199	22.979	136.4	78	16	1	30	12	48	0
19	200	21.966	136.3	79	-12	1	30	12	48	0
20	201	20.955	136.3	80	3	1	30	12	48	0

FIELD DATA TABLE

SHOT NUMBER 7 SHOT POINT 10 TEAM 2
 SHOT TIME: 309: 9: 2: 0.010

LOC	DIST(KM)	AZIM	UNIT	CHRON	CHAN	C1	C2	C3	TAPE	GRADE
1	120	100.612	144.1	21	1	30	12	88	3	0
2	119	101.753	144.3	22	6	2	30	12	48	0
3	118	102.671	144.6	23	3	1	30	12	68	0
4	117	103.688	144.7	24	-8	1	30	12	68	0
5	116	104.770	144.8	25	-13	1	30	12	68	3
6	115	105.717	145.0	26	8	1	30	12	88	0
7	114	106.648	144.9	27	0	2	30	12	88	0
8	113	108.296	144.6	28	-32	2	30	12	68	0
9	112	110.646	144.0	29	3	30	12	48	3	0
10	111	112.517	144.0	30	7	30	12	48	2	0
11	110	113.826	144.5	31	64	1	30	12	48	0
12	109	115.149	144.9	32	12	2	30	12	48	0
13	108	117.488	144.6	33	12	2	30	12	48	0
14	107	119.732	144.4	34	5	2	30	12	48	0
15	106	121.824	144.4	35	-25	1	30	12	48	0
16	105	123.290	144.7	36	-2	2	30	12	48	0
17	104	124.749	145.2	37	2	2	30	12	48	2
18	103	126.998	145.0	38	3	2	30	12	48	0
19	102	129.232	144.8	39	3	2	30	12	48	0
20	101	131.475	144.6	40	2	2	30	12	48	0

FIELD DATA TABLE

SHOT NUMBER 8 SHOT POINT 19 TEAM 1
 SHOT TIME: 309; 9: 4; 0.007

LOC	DIST(KM)	AZIM	UNIT	CHRON	CHAN	C1	C2	C3	TAPE	GRADE
1	142	7.260	133.1	1	2	3	30	12	48	0
2	143	6.111	134.2	2	-10	3	30	12	48	0
3	144	5.030	132.5	3	7	3	30	12	48	0
4	145	3.929	139.9	4	-34	3	30	12	68	0
5	146	2.950	134.3	5	8	3	30	12	68	0
6	147	2.066	122.8	6	3	3	30	12	68	1
7	148	1.149	106.6	7	-14	3	30	12	88	0
8	169	20.828	341.7	8	-17	1	30	12	68	0
9	170	21.800	341.5	9	22	1	30	12	68	0
10	171	22.805	341.4	10	34	1	30	12	68	0
11	172	23.874	341.3	11	-12	1	30	12	48	0
12	173	24.820	341.0	12	0	1	30	12	48	0
13	174	25.847	341.1	13	-5	1	30	12	48	0
14	175	26.927	341.0	14	5	1	30	12	48	0
15	176	27.913	340.6	15	1	1	30	12	68	0
16	177	28.878	340.3	16	9	1	30	12	68	0
17	178	29.896	340.1	17	6	1	30	12	68	0
18	179	30.833	339.1	18	-10	1	30	12	88	0
19	180	31.732	337.9	19	-10	1	30	12	88	0
20	181	32.626	337.2	20	0	2	30	12	88	0

FIELD DATA TABLE

SHOT NUMBER 7 SHOT POINT 10 TEAM 5
 SHOT TIME: 309; 9: 2; 0.010

LOC	DIST(KM)	AZIM	UNIT	CHRON	CHAN	C1	C2	C3	TAPE	GRADE
1	149	72.760	145.3	81	12	2	30	12	88	0
2	150	71.579	144.8	82	-11	2	30	12	88	0
3	151	70.597	144.2	83	17	2	30	12	68	0
4	152	69.581	144.1	84	-14	1	30	12	48	0
5	153	68.650	144.2	85	-20	2	30	12	48	0
6	154	67.652	144.5	86	0	1	30	12	48	0
7	156	65.689	143.7	87	-13	1	30	12	48	0
8	157	64.698	143.5	88	22	1	30	12	48	0
9	158	63.722	143.3	89	0	2	30	12	48	0
10	155	66.663	144.4	90	--	1	30	12	48	0
11	159	62.714	142.9	91	6	1	30	12	48	0
12	160	61.721	142.4	92	-3	1	30	12	48	0
13	161	60.768	142.4	93	-7	1	30	12	48	0
14	162	59.784	142.1	94	19	1	30	12	48	0
15	163	58.815	141.7	95	2	1	30	12	48	0
16	164	57.852	141.1	96	-37	1	30	12	68	0
17	165	56.890	140.6	97	5	1	30	12	68	0
18	166	56.001	140.1	98	-30	1	30	12	88	0
19	167	54.970	139.6	99	15	1	30	12	88	0
20	168	53.998	139.4	100	10	1	30	12	88	3

FIELD DATA TABLE

SHOT NUMBER 8 SHOT POINT 19 TEAM 2
 SHOT TIME: 309; 9: 4; 0.007

LOC	DIST(KM)	AZIM	UNIT	CHRON	CHAN	C1	C2	C3	TAPE	GRADE
1	120	27.927	141.1	21	1	1	30	12	88	0
2	119	29.056	141.6	22	6	1	30	12	48	0
3	118	29.947	142.8	23	3	1	30	12	68	0
4	117	30.957	143.3	24	-8	1	30	12	68	0
5	116	32.035	143.5	25	-13	1	30	12	68	0
6	115	32.974	144.3	26	8	1	30	12	88	0
7	114	33.908	144.0	27	0	1	30	12	88	0
8	113	35.568	143.2	28	-32	1	30	12	68	0
9	112	37.962	141.5	29	7	2	30	12	68	0
10	111	39.829	141.7	30	3	3	30	12	48	2
11	110	41.104	143.0	31	64	1	30	12	48	0
12	109	42.406	144.4	32	7	1	30	12	48	0
13	108	44.755	143.7	33	12	1	30	12	48	0
14	107	47.009	143.2	34	5	1	30	12	48	0
15	106	49.104	143.1	35	-25	1	30	12	48	0
16	105	50.554	143.9	36	-2	1	30	12	48	0
17	104	52.001	145.1	37	2	2	30	12	48	2
18	103	54.253	144.7	38	3	2	30	12	48	0
19	102	56.492	144.3	39	3	2	30	12	48	0
20	101	58.741	143.9	40	2	2	30	12	48	0

FIELD DATA TABLE

SHOT NUMBER 7 SHOT POINT 10 TEAM 6
 SHOT TIME: 309; 9: 2; 0.010

LOC	DIST(KM)	AZIM	UNIT	CHRON	CHAN	C1	C2	C3	TAPE	GRADE
1	203	18.923	136.4	101	10	30	12	48	1	1
2	204	17.911	136.4	102	2	1	30	12	48	0
3	205	16.895	136.4	103	--	30	12	48	3	3
4	206	15.871	136.4	104	-3	1	30	12	48	0
5	207	14.860	136.4	105	6	1	30	12	48	0
6	208	13.848	136.5	106	-5	1	30	12	48	0
7	209	12.827	136.6	107	-9	1	30	12	48	0
8	210	11.820	136.7	108	6	1	30	12	48	0
9	211	10.795	136.6	109	1	1	30	12	48	0
10	213	8.791	137.0	110	7	3	30	12	48	0
11	214	7.753	137.0	111	19	3	30	12	48	0
12	215	6.725	137.0	112	-7	3	30	12	48	0
13	216	5.710	137.4	113	5	3	30	12	48	0
14	217	4.685	137.6	114	0	3	30	12	48	0
15	218	3.661	137.9	115	0	3	30	12	68	0
16	219	2.640	138.6	116	0	3	30	12	68	0
17	220	1.642	140.4	117	1	1	30	12	68	2
18	221	0.658	145.6	118	-4	3	30	12	88	0
19	222	0.141	290.3	119	2	3	30	12	88	0
20	11	36.209	325.5	120	--	30	12	88	3	3

FIELD DATA TABLE

SHOT NUMBER 8 SHOT POINT 19 TEAM 5
SHOT TIME: 309: 9: 4: 0.007

LOC	DIST(KM)	AZIM	UNIT	CHRON	CHAN	C1	C2	C3	TAPE	GRADE
1	149	0.088	81	12	3	30	12	88	0	0
2	150	1.392	82	-11	3	30	12	88	0	0
3	151	2.665	83	17	3	30	12	68	0	0
4	152	3.542	84	-14	3	30	12	48	0	0
5	153	4.358	85	-20	3	30	12	48	0	0
6	154	5.212	86	0	3	30	12	48	0	0
7	156	7.362	87	-13	3	30	12	48	0	0
8	157	8.366	88	22	3	30	12	48	0	0
9	158	9.378	89	0	3	30	12	48	0	0
10	155	6.198	90	--	3	30	12	48	0	0
11	159	10.461	91	6	3	30	12	48	0	0
12	160	11.565	92	-3	3	30	12	48	0	0
13	161	12.494	93	-7	3	30	12	48	0	0
14	162	13.526	94	19	1	30	12	48	0	0
15	163	14.572	95	2	3	30	12	48	0	0
16	164	15.685	96	-37	1	30	12	68	0	0
17	165	16.755	97	5	1	30	12	68	0	0
18	166	17.763	98	-30	1	30	12	88	0	0
19	167	18.890	99	15	1	30	12	88	0	0
20	168	19.855	100	10	1	30	12	88	0	3

LOC	DIST(KM)	AZIM	UNIT	CHRON	CHAN	C1	C2	C3	TAPE	GRADE
1	121	27.575	41	4	1	30	12	88	0	0
2	122	26.884	42	2	1	30	12	88	0	0
3	123	25.847	43	2	1	30	12	68	0	0
4	124	25.023	44	7	1	30	12	68	0	0
5	125	24.133	45	-2	1	30	12	68	0	0
6	126	23.154	46	11	1	30	12	68	0	0
7	127	21.953	47	22	1	30	12	48	0	0
8	128	20.756	48	-24	3	30	12	48	0	0
9	129	20.094	49	4	1	30	12	48	0	0
10	131	18.104	50	7	3	30	12	48	0	0
11	132	17.080	51	4	1	30	12	48	0	0
12	133	16.291	52	-3	1	30	12	48	0	0
13	134	15.124	53	5	1	30	12	48	0	0
14	136	13.087	54	4	1	30	12	48	0	0
15	137	11.748	55	-19	1	30	12	48	0	0
16	138	10.959	56	0	3	30	12	48	0	0
17	139	9.976	57	7	3	30	12	48	0	0
18	140	8.847	58	7	3	30	12	48	0	0
19	141	8.002	59	-3	3	30	12	48	0	0
20	143	85.537	60	-4	1	30	12	48	0	3

SHOT NUMBER 8 SHOT POINT 19 TEAM 3
SHOT TIME: 309: 9: 4: 0.007

FIELD DATA TABLE

FIELD DATA TABLE

SHOT NUMBER 8 SHOT POINT 19 TEAM 6
SHOT TIME: 309: 9: 4: 0.007

LOC	DIST(KM)	AZIM	UNIT	CHRON	CHAN	C1	C2	C3	TAPE	GRADE
1	203	54.140	101	10	2	30	12	48	1	1
2	204	55.133	102	2	2	30	12	48	0	0
3	205	56.127	103	--	--	30	12	48	3	3
4	206	57.127	104	-3	1	30	12	48	0	0
5	207	58.117	105	6	1	30	12	48	0	0
6	208	59.107	106	-5	1	30	12	48	0	0
7	209	60.104	107	-9	1	30	12	48	0	0
8	210	61.093	108	6	1	30	12	48	0	0
9	211	62.102	109	1	2	30	12	48	0	0
10	213	64.066	110	7	1	30	12	48	0	0
11	214	65.089	111	19	1	30	12	48	0	0
12	215	66.103	112	-7	1	30	12	48	0	0
13	216	67.099	113	5	2	30	12	48	0	0
14	217	68.111	114	0	2	30	12	48	0	0
15	218	69.122	115	0	2	30	12	68	0	0
16	219	70.128	116	0	1	30	12	68	0	0
17	220	71.114	117	1	1	30	12	68	2	2
18	221	72.092	118	-4	1	30	12	88	0	0
19	222	72.865	119	2	1	30	12	88	0	0
20	11	108.958	120	--	--	30	12	88	0	3

SHOT NUMBER 8 SHOT POINT 19 TEAM 4
SHOT TIME: 309: 9: 4: 0.007

LOC	DIST(KM)	AZIM	UNIT	CHRON	CHAN	C1	C2	C3	TAPE	GRADE
1	182	33.576	61	11	1	30	12	68	0	0
2	183	34.523	62	9	1	30	12	68	0	0
3	184	35.731	63	10	1	30	12	68	0	0
4	185	36.469	64	5	1	30	12	48	0	0
5	186	37.438	65	-25	1	30	12	48	0	0
6	187	38.414	66	6	1	30	12	48	0	0
7	188	39.369	67	-10	1	30	12	48	0	0
8	189	40.350	68	-10	1	30	12	48	0	0
9	190	41.316	69	6	1	30	12	48	0	0
10	191	42.278	70	12	1	30	12	48	0	0
11	192	43.277	71	-11	1	30	12	48	0	0
12	193	44.261	72	-10	1	30	12	48	0	0
13	194	45.208	73	6	1	30	12	48	0	0
14	195	46.185	74	2	2	30	12	48	0	0
15	196	47.188	75	10	2	30	12	48	0	0
16	197	48.179	76	34	1	30	12	48	0	0
17	198	49.207	77	6	2	30	12	48	0	0
18	199	50.187	78	16	2	30	12	48	0	0
19	200	51.177	79	-12	2	30	12	48	0	0
20	201	52.161	80	3	1	30	12	48	0	0

FIELD DATA TABLE

SHOT NUMBER 9 SHOT POINT 18 TEAM 3
 SHOT TIME: 309: 9: 6: 0.011

LOC	DIST(KM)	AZIM	UNIT	CHRON	CHAN	C1	C2	C3	TAPE	GRADE
1	121	45.651	150.1	41	4	2	30	12 88	0	0
2	122	44.945	150.1	42	2	2	30	12 88	0	0
3	123	43.915	150.2	43	2	2	30	12 68	0	0
4	124	43.100	150.4	44	7	2	30	12 68	0	0
5	125	42.046	149.2	45	-2	2	30	12 68	2	2
6	126	41.166	150.1	46	11	1	30	12 68	0	0
7	127	40.010	150.6	47	22	2	30	12 48	0	0
8	128	38.952	151.9	48	-24	2	30	12 48	0	0
9	129	38.137	150.7	49	4	2	30	12 48	2	2
10	131	36.193	151.0	50	7	2	30	12 48	0	0
11	132	35.173	151.6	51	4	2	30	12 48	0	0
12	133	34.307	151.2	52	-3	2	30	12 48	0	0
13	134	33.115	151.3	53	5	2	30	12 48	0	0
14	136	31.210	152.7	54	4	2	30	12 48	0	0
15	137	30.039	154.2	55	-19	2	30	12 48	0	0
16	138	29.283	154.6	56	0	2	30	12 48	0	0
17	139	28.314	155.0	57	0	1	30	12 48	0	0
18	140	27.117	154.8	58	7	2	30	12 48	0	0
19	141	26.268	155.1	59	-3	2	30	12 48	0	0
20	13	103.743	149.2	60	-4	2	30	12 48	3	3

FIELD DATA TABLE

SHOT NUMBER 9 SHOT POINT 18 TEAM 1
 SHOT TIME: 309: 9: 6: 0.011

LOC	DIST(KM)	AZIM	UNIT	CHRON	CHAN	C1	C2	C3	TAPE	GRADE
1	142	25.412	154.7	1	2	2	30	12 48	0	0
2	143	24.390	153.9	2	-10	2	30	12 48	0	0
3	144	23.330	156.6	3	7	1	30	12 48	0	0
4	145	22.524	158.9	4	-34	2	30	12 68	0	0
5	146	21.490	159.1	5	8	2	30	12 68	0	0
6	147	20.476	159.1	6	3	3	30	12 68	1	1
7	148	19.513	160.0	7	-14	2	30	12 88	0	0
8	169	2.014	331.0	8	-17	3	30	12 68	0	0
9	170	2.990	332.4	9	22	3	30	12 68	0	0
10	171	3.991	334.1	10	34	1	30	12 68	0	0
11	172	5.055	335.4	11	-12	3	30	12 48	0	0
12	173	6.010	335.0	12	0	1	30	12 48	0	0
13	174	7.029	336.2	13	-5	1	30	12 48	0	0
14	175	8.107	336.7	14	5	1	30	12 48	0	0
15	176	9.106	335.9	15	1	1	30	12 68	0	0
16	177	10.079	335.5	16	9	1	30	12 68	0	0
17	178	11.105	335.2	17	6	2	30	12 68	0	0
18	179	12.085	333.2	18	-10	2	30	12 88	0	0
19	180	13.056	330.6	19	-10	1	30	12 88	0	0
20	181	13.987	329.6	20	0	2	30	12 88	0	0

FIELD DATA TABLE

SHOT NUMBER 9 SHOT POINT 18 TEAM 4
 SHOT TIME: 309: 9: 6: 0.011

LOC	DIST(KM)	AZIM	UNIT	CHRON	CHAN	C1	C2	C3	TAPE	GRADE
1	182	14.977	328.7	61	11	1	30	12 68	0	0
2	183	15.963	327.9	62	9	2	30	12 68	0	0
3	184	17.215	327.1	63	10	2	30	12 68	0	0
4	185	17.982	326.7	64	5	2	30	12 48	0	0
5	186	18.992	326.0	65	-25	2	30	12 48	0	0
6	187	20.000	325.6	66	6	2	30	12 48	0	0
7	188	20.989	325.1	67	-10	1	30	12 48	0	0
8	189	22.003	324.8	68	-10	2	30	12 48	0	0
9	190	23.000	324.4	69	6	2	30	12 48	0	0
10	191	23.992	324.0	70	12	2	30	12 48	0	0
11	192	25.021	323.7	71	-11	2	30	12 48	0	0
12	193	26.033	323.5	72	-10	2	30	12 48	0	0
13	194	27.007	323.2	73	6	2	30	12 48	0	0
14	195	28.008	323.0	74	2	2	30	12 48	0	0
15	196	29.038	322.7	75	10	2	30	12 48	0	0
16	197	30.053	322.5	76	34	2	30	12 48	0	0
17	198	31.106	322.3	77	6	2	30	12 48	0	0
18	199	32.108	322.1	78	16	2	30	12 48	0	0
19	200	33.117	322.0	79	-12	2	30	12 48	0	0
20	201	34.124	321.8	80	3	2	30	12 48	0	0

FIELD DATA TABLE

SHOT NUMBER 9 SHOT POINT 18 TEAM 2
 SHOT TIME: 309: 9: 6: 0.011

LOC	DIST(KM)	AZIM	UNIT	CHRON	CHAN	C1	C2	C3	TAPE	GRADE
1	120	45.969	149.8	21	1	2	30	12 88	0	0
2	119	47.123	149.9	22	6	2	30	12 48	0	0
3	118	48.094	150.5	23	3	2	30	12 68	0	0
4	117	49.129	150.7	24	-8	2	30	12 68	0	0
5	116	50.214	150.6	25	-13	2	30	12 68	0	0
6	115	51.197	151.0	26	8	2	30	12 88	0	0
7	114	52.108	150.7	27	0	2	30	12 88	0	0
8	113	53.700	150.0	28	-32	2	30	12 68	0	0
9	112	55.943	148.5	29	7	2	30	12 68	0	0
10	111	57.810	148.4	30	3	3	30	12 48	2	2
11	110	59.185	149.2	31	64	2	30	12 48	0	0
12	109	60.582	150.0	32	7	2	30	12 48	0	0
13	108	62.865	149.3	33	12	2	30	12 48	0	0
14	107	65.072	148.8	34	5	2	30	12 48	0	0
15	106	67.149	148.5	35	-25	2	30	12 48	0	0
16	105	68.660	149.0	36	-2	2	30	12 48	0	0
17	104	70.191	149.8	37	2	2	30	12 48	2	2
18	103	72.403	149.3	38	3	2	30	12 48	0	0
19	102	74.602	148.9	39	3	2	30	12 48	0	0
20	101	76.816	148.5	40	2	2	30	12 48	0	0

FIELD DATA TABLE

SHOT NUMBER 10 SHOT POINT 18 TEAM 1
 SHOT TIME: 309: 9:30: 0.013

LOC	DIST(KM)	AZIM	UNIT	CHRON	CHAN	C1	C2	C3	TAPE	GRADE
1	142	25.412	1	2	2	30	12	48	0	0
2	143	24.390	2	-11	2	30	12	48	0	0
3	144	23.330	3	7	1	30	12	48	0	0
4	145	22.524	4	-35	2	30	12	68	0	0
5	146	21.490	5	8	2	30	12	68	0	0
6	147	20.476	6	3	3	30	12	68	1	1
7	148	19.513	7	-15	2	30	12	68	0	0
8	169	2.014	8	-17	3	30	12	68	0	0
9	170	2.990	9	22	3	30	12	68	0	0
10	171	3.991	10	35	1	30	12	68	0	0
11	172	5.055	11	-12	1	30	12	48	0	0
12	173	6.010	12	0	1	30	12	48	0	0
13	174	7.029	13	-5	1	30	12	48	0	0
14	175	8.107	14	5	2	30	12	48	0	0
15	176	9.106	15	1	1	30	12	68	0	0
16	177	10.079	16	9	1	30	12	68	0	0
17	178	11.105	17	6	2	30	12	68	0	0
18	179	12.085	18	-10	2	30	12	88	0	0
19	180	13.056	19	-10	2	30	12	88	3	3
20	181	13.987	20	0	2	30	12	88	0	0

FIELD DATA TABLE

SHOT NUMBER 9 SHOT POINT 18 TEAM 5
 SHOT TIME: 309: 9: 6: 0.011

LOC	DIST(KM)	AZIM	UNIT	CHRON	CHAN	C1	C2	C3	TAPE	GRADE
1	149	18.838	81	12	2	30	12	88	0	0
2	150	17.514	82	-11	2	30	12	88	0	0
3	151	16.344	83	17	2	30	12	68	0	0
4	152	15.361	84	-14	1	30	12	48	0	0
5	153	14.498	85	-20	1	30	12	48	0	0
6	154	13.675	86	0	1	30	12	48	0	0
7	156	11.496	87	-13	1	30	12	48	0	0
8	157	10.500	88	22	1	30	12	48	0	0
9	158	9.493	89	0	1	30	12	48	0	0
10	155	12.721	90	--	1	30	12	48	0	0
11	159	8.406	91	6	1	30	12	48	0	0
12	160	7.294	92	-3	1	30	12	48	0	0
13	161	6.387	93	-7	1	30	12	48	0	0
14	162	5.363	94	19	3	30	12	48	0	0
15	163	4.319	95	2	3	30	12	48	0	0
16	164	3.183	96	-37	3	30	12	68	0	0
17	165	2.108	97	5	3	30	12	68	0	0
18	166	1.092	98	-30	3	30	12	88	0	0
19	167	0.054	99	15	3	30	12	88	0	0
20	168	1.036	100	10	10	30	12	88	3	3

FIELD DATA TABLE

SHOT NUMBER 10 SHOT POINT 18 TEAM 2
 SHOT TIME: 309: 9:30: 0.013

LOC	DIST(KM)	AZIM	UNIT	CHRON	CHAN	C1	C2	C3	TAPE	GRADE
1	120	45.969	21	1	1	30	12	88	2	2
2	119	47.123	22	6	6	30	12	48	2	2
3	118	48.094	23	3	3	30	12	68	0	0
4	117	49.129	24	-8	2	30	12	68	0	0
5	116	50.214	25	-13	2	30	12	88	0	0
6	115	51.197	26	9	2	30	12	88	0	0
7	114	52.108	27	0	2	30	12	68	0	0
8	113	53.700	28	-33	2	30	12	68	0	0
9	112	55.943	29	7	2	30	12	68	0	0
10	111	57.810	30	3	2	30	12	48	0	0
11	110	59.185	31	66	3	30	12	48	2	2
12	109	60.582	32	7	2	30	12	48	0	0
13	108	62.865	33	13	2	30	12	48	0	0
14	107	65.072	34	5	2	30	12	48	0	0
15	106	67.149	35	-26	2	30	12	48	0	0
16	105	68.660	36	-2	2	30	12	48	0	0
17	104	70.191	37	2	2	30	12	48	2	2
18	103	72.403	38	3	2	30	12	48	0	0
19	102	74.602	39	3	2	30	12	48	0	0
20	101	76.816	40	2	2	30	12	48	0	0

FIELD DATA TABLE

SHOT NUMBER 9 SHOT POINT 18 TEAM 6
 SHOT TIME: 309: 9: 6: 0.011

LOC	DIST(KM)	AZIM	UNIT	CHRON	CHAN	C1	C2	C3	TAPE	GRADE
1	203	36.146	101	10	10	30	12	48	1	1
2	204	37.155	102	2	2	30	12	48	0	0
3	205	38.168	103	--	--	30	12	48	3	3
4	206	39.188	104	-3	2	30	12	48	0	0
5	207	40.195	105	6	2	30	12	48	0	0
6	208	41.203	106	-5	2	30	12	48	0	0
7	209	42.220	107	-9	2	30	12	48	0	0
8	210	43.224	108	6	2	30	12	48	0	0
9	211	44.247	109	1	3	30	12	48	0	0
10	213	46.244	110	7	2	30	12	48	0	0
11	214	47.281	111	19	2	30	12	48	0	0
12	215	48.307	112	-7	1	30	12	48	0	0
13	216	49.319	113	5	2	30	12	48	0	0
14	217	50.343	114	0	2	30	12	48	0	0
15	218	51.365	115	0	2	30	12	68	0	0
16	219	52.385	116	0	2	30	12	68	0	0
17	220	53.383	117	1	1	30	12	68	2	2
18	221	54.370	118	-4	2	30	12	88	0	0
19	222	55.148	119	2	2	30	12	88	0	0
20	11	91.117	120	--	--	30	12	88	3	3

FIELD DATA TABLE

SHOT NUMBER 10 SHOT POINT 18 TEAM 5
SHOT TIME: 309: 9:30: 0.013

LOC	DIST(KM)	AZIM	UNIT	CHRON	CHAN	C1	C2	C3	TAPE	GRADE
1	149	18.838	162.6	81	12	2	30	12	88	0
2	150	17.514	161.6	82	-11	2	30	12	88	0
3	151	16.344	159.9	83	17	2	30	12	68	0
4	152	15.361	160.8	84	-15	2	30	12	48	0
5	153	14.498	162.2	85	-20	2	30	12	48	0
6	154	13.675	165.0	86	0	2	30	12	48	0
7	156	11.496	163.9	87	-13	1	30	12	48	0
8	157	10.500	164.7	88	23	1	30	12	48	0
9	158	9.493	165.4	89	0	1	30	12	48	0
10	155	12.721	166.2	90	--	1	30	12	48	0
11	159	8.406	165.4	91	6	1	30	12	48	0
12	160	7.294	164.6	92	-3	2	30	12	48	0
13	161	6.387	167.1	93	-7	1	30	12	48	0
14	162	5.363	168.5	94	20	1	30	12	48	0
15	163	4.319	169.5	95	2	3	30	12	68	0
16	164	3.183	167.9	96	-38	3	30	12	68	0
17	165	2.108	168.1	97	5	3	30	12	68	0
18	166	1.092	166.7	98	-30	3	30	12	68	0
19	167	0.064	287.5	99	16	3	30	12	88	0
20	168	1.036	327.8	100	10	3	30	12	88	3

FIELD DATA TABLE

SHOT NUMBER 10 SHOT POINT 18 TEAM 3
SHOT TIME: 309: 9:30: 0.013

LOC	DIST(KM)	AZIM	UNIT	CHRON	CHAN	C1	C2	C3	TAPE	GRADE
1	121	45.631	150.1	41	4	2	30	12	88	0
2	122	44.945	150.1	42	2	2	30	12	88	0
3	123	43.915	150.2	43	3	2	30	12	68	0
4	124	43.100	150.4	44	7	2	30	12	68	0
5	125	42.046	149.2	45	-2	2	30	12	68	0
6	126	41.166	150.1	46	11	2	30	12	68	0
7	127	40.010	150.6	47	22	1	30	12	48	0
8	128	38.952	151.9	48	-24	2	30	12	48	0
9	129	38.137	150.7	49	4	2	30	12	48	0
10	131	36.133	151.0	50	7	2	30	12	48	0
11	132	35.173	151.6	51	4	2	30	12	48	0
12	133	34.307	151.2	52	-3	2	30	12	48	0
13	134	33.115	151.3	53	5	2	30	12	48	0
14	136	31.210	152.7	54	5	2	30	12	48	0
15	137	30.039	154.2	55	-19	2	30	12	48	0
16	138	29.283	154.6	56	0	2	30	12	48	0
17	139	28.314	155.0	57	0	1	30	12	48	0
18	140	27.117	154.8	58	7	2	30	12	48	0
19	141	26.268	155.1	59	-3	2	30	12	48	0
20	13	103.743	149.2	60	-4	2	30	12	48	3

FIELD DATA TABLE

SHOT NUMBER 10 SHOT POINT 18 TEAM 6
SHOT TIME: 309: 9:30: 0.013

LOC	DIST(KM)	AZIM	UNIT	CHRON	CHAN	C1	C2	C3	TAPE	GRADE
1	203	36.146	321.5	101	10	2	30	12	48	1
2	204	37.155	321.4	102	2	2	30	12	48	0
3	205	38.168	321.2	103	--	2	30	12	48	3
4	206	39.188	321.1	104	-3	2	30	12	48	0
5	207	40.195	321.0	105	6	2	30	12	48	0
6	208	41.203	320.8	106	-5	2	30	12	48	0
7	209	42.220	320.7	107	-9	2	30	12	48	0
8	210	43.224	320.6	108	6	2	30	12	48	0
9	211	44.247	320.5	109	1	2	30	12	48	0
10	213	46.244	320.3	110	7	2	30	12	48	0
11	214	47.281	320.2	111	20	2	30	12	48	0
12	215	48.307	320.2	112	-7	2	30	12	48	0
13	216	49.319	320.1	113	5	2	30	12	48	0
14	217	50.343	320.0	114	0	2	30	12	48	0
15	218	51.365	319.9	115	0	2	30	12	68	0
16	219	52.385	319.9	116	0	2	30	12	68	0
17	220	53.383	319.8	117	1	2	30	12	68	2
18	221	54.370	319.7	118	-4	2	30	12	68	0
19	222	55.148	319.7	119	2	2	30	12	88	0
20	11	91.117	322.2	120	--	2	30	12	88	3

FIELD DATA TABLE

SHOT NUMBER 10 SHOT POINT 18 TEAM 4
SHOT TIME: 309: 9:30: 0.013

LOC	DIST(KM)	AZIM	UNIT	CHRON	CHAN	C1	C2	C3	TAPE	GRADE
1	182	14.977	328.7	61	11	2	30	12	68	0
2	183	15.963	327.9	62	9	2	30	12	68	0
3	184	17.215	327.1	63	10	1	30	12	68	0
4	185	17.982	326.7	64	5	2	30	12	48	0
5	186	18.992	326.0	65	-26	2	30	12	48	0
6	187	20.000	325.6	66	6	2	30	12	48	0
7	188	20.989	325.1	67	-10	1	30	12	48	0
8	189	22.003	324.8	68	-10	2	30	12	48	0
9	190	23.000	324.4	69	6	2	30	12	48	0
10	191	23.992	324.0	70	12	2	30	12	48	0
11	192	25.021	323.7	71	-12	2	30	12	48	0
12	193	26.033	323.5	72	-10	2	30	12	48	0
13	194	27.007	323.2	73	6	2	30	12	48	0
14	195	28.008	323.0	74	2	2	30	12	48	0
15	196	29.038	322.7	75	10	2	30	12	48	0
16	197	30.053	322.5	76	34	2	30	12	48	0
17	198	31.106	322.3	77	6	2	30	12	48	0
18	199	32.117	322.1	78	16	2	30	12	48	0
19	200	33.117	322.0	79	-12	2	30	12	48	0
20	201	34.124	321.8	80	3	2	30	12	48	0

FIELD DATA TABLE

SHOT NUMBER 11 SHOT POINT 12 TEAM 3
SHOT TIME: 312: 6: 0: 0.006

LOC	DIST(KM)	AZIM	UNIT	CHRON	CHAN	C1	C2	C3	TAPE	GRADE
1	341	128.660	41	13	2	30	12	48	0	0
2	342	129.131	42	1	2	30	12	48	0	0
3	343	129.679	43	2	2	30	12	48	0	3
4	344	130.167	44	9	2	30	12	48	0	0
5	345	130.720	45	0	0	30	12	48	0	3
6	346	131.227	46	10	2	30	12	48	0	0
7	347	131.751	47	16	2	30	12	48	0	0
8	348	132.268	48	-18	2	30	12	48	0	0
9	349	132.767	49	2	2	30	12	48	0	0
10	350	133.302	50	6	2	30	12	48	0	0
11	351	133.844	51	71	1	30	12	48	4	4
12	352	134.351	52	-4	2	30	12	48	0	0
13	353	134.880	53	3	2	30	12	48	0	0
14	354	135.391	54	3	2	30	12	48	0	0
15	355	135.880	55	-13	2	30	12	48	0	0
16	356	136.420	56	5	2	30	12	68	0	0
17	357	136.915	57	3	2	30	12	68	0	0
18	358	137.460	58	5	2	30	12	68	0	0
19	359	137.952	59	-2	2	30	12	68	0	0
20	360	138.425	60	-4	2	30	12	68	0	0

SHOT NUMBER 11 SHOT POINT 12 TEAM 1
SHOT TIME: 312: 6: 0: 0.005

LOC	DIST(KM)	AZIM	UNIT	CHRON	CHAN	C1	C2	C3	TAPE	GRADE
1	381	148.388	23.3	1	3	30	12	48	0	0
2	382	148.880	223.2	2	-8	30	12	48	1	1
3	383	149.346	223.1	3	5	30	12	48	0	0
4	384	149.848	223.1	4	-32	30	12	48	0	0
5	385	150.313	223.0	5	7	30	12	48	0	0
6	386	150.775	222.9	6	2	30	12	48	0	0
7	387	151.267	222.9	7	-14	2	30	12	48	0
8	388	151.739	222.8	8	-19	2	30	12	48	0
9	389	152.322	222.7	9	17	2	30	12	48	0
10	390	152.769	222.6	10	25	2	30	12	48	0
11	391	153.199	222.4	11	14	2	30	12	48	0
12	392	153.644	222.3	12	0	2	30	12	48	0
13	393	154.070	222.1	13	-5	2	30	12	48	0
14	394	154.501	222.0	14	1	30	12	48	1	1
15	395	154.968	221.9	15	0	2	30	12	48	0
16	396	155.460	221.9	16	8	30	12	48	3	3
17	397	155.867	221.7	17	8	2	30	12	48	0
18	5	88.772	226.6	18	-15	30	12	88	3	3
19	6	72.248	227.2	19	-14	2	30	12	88	0
20	7	41.024	233.8	20	0	30	12	88	3	3

FIELD DATA TABLE

SHOT NUMBER 11 SHOT POINT 12 TEAM 4
SHOT TIME: 312: 6: 0: 0.006

LOC	DIST(KM)	AZIM	UNIT	CHRON	CHAN	C1	C2	C3	TAPE	GRADE
1	311	114.008	225.7	61	6	30	12	48	0	0
2	312	114.372	225.5	62	5	30	12	48	0	0
3	313	114.825	225.3	63	5	30	12	48	0	0
4	314	115.232	225.2	64	--	30	12	48	1	1
5	315	115.828	225.2	65	-18	30	12	48	2	2
6	316	116.533	225.6	66	3	30	12	48	0	0
7	317	116.958	225.4	67	0	2	30	12	48	0
8	318	117.349	225.2	68	-3	1	30	12	48	0
9	319	117.706	225.1	69	3	2	30	12	48	0
10	320	118.230	224.9	70	8	2	30	12	48	0
11	331	123.589	224.5	71	3	2	30	12	88	0
12	332	124.211	224.4	72	6	2	30	12	88	0
13	333	124.579	224.4	73	2	2	30	12	88	0
14	334	125.080	224.4	74	1	2	30	12	88	0
15	335	125.564	224.4	75	5	2	30	12	88	0
16	336	126.063	224.3	76	--	30	12	68	1	1
17	337	126.577	224.4	77	-2	2	30	12	68	3
18	338	127.083	224.3	78	12	2	30	12	68	0
19	339	127.605	224.2	79	-64	2	30	12	68	0
20	340	128.118	224.3	80	3	2	30	12	68	0

SHOT NUMBER 11 SHOT POINT 12 TEAM 2
SHOT TIME: 312: 6: 0: 0.006

LOC	DIST(KM)	AZIM	UNIT	CHRON	CHAN	C1	C2	C3	TAPE	GRADE
1	310	113.377	225.5	21	0	30	12	88	0	0
2	309	112.944	225.8	22	5	30	12	88	0	0
3	308	112.514	226.0	23	4	1	30	12	88	0
4	307	111.899	225.8	24	-5	2	30	12	48	0
5	306	111.336	225.7	25	-9	2	30	12	48	0
6	305	110.915	225.8	26	5	2	30	12	48	0
7	304	110.381	225.7	27	0	2	30	12	48	0
8	303	109.890	225.8	28	-24	2	30	12	48	0
9	142	108.898	225.9	29	5	2	30	12	48	0
10	302	109.366	225.8	30	2	2	30	12	48	0
11	321	118.747	224.9	31	4	2	30	12	48	0
12	322	119.170	224.8	32	7	2	30	12	48	0
13	323	119.630	224.7	33	20	2	30	12	48	0
14	324	120.118	224.6	34	6	2	30	12	48	0
15	325	120.590	224.6	35	-19	2	30	12	48	0
16	326	121.068	224.5	36	0	2	30	12	48	0
17	327	121.603	224.4	37	4	30	12	48	2	2
18	328	122.064	224.5	38	3	2	30	12	48	0
19	329	122.644	224.6	39	1	2	30	12	48	0
20	330	123.075	224.5	40	3	3	30	12	88	0

FIELD DATA TABLE

SHOT NUMBER 11 SHOT POINT 12 TEAM 5
SHOT TIME: 312: 6: 0: 0.006

LOC	DIST(KM)	AZIM	UNIT	CHRON	CHAN	C1	C2	C3	TAPE	GRADE
1	398	156.321	221.6	81	86	2	30	12	48	0
2	399	156.788	221.5	82	-6	2	30	12	48	0
3	400	157.277	221.5	83	9	2	30	12	68	2
4	401	157.831	221.5	84	-8	2	30	12	88	0
5	402	158.368	221.6	85	-11	2	30	12	88	0
6	403	158.893	221.6	86	0	2	30	12	88	0
7	404	159.240	221.6	87	-8	2	30	12	88	0
8	405	159.899	221.7	88	12	2	30	12	88	0
9	406	160.442	221.7	89	0	2	30	12	88	0
10	407	160.988	221.8	90	3	2	30	12	68	0
11	408	161.496	221.9	91	4	2	30	12	68	0
12	409	162.029	222.0	92	-2	2	30	12	68	0
13	410	162.541	222.0	93	-3	2	30	12	68	0
14	411	163.043	221.9	94	11	2	30	12	68	0
15	413	164.076	222.0	95	-19	2	30	12	48	0
16	415	165.208	222.1	96	1	2	30	12	48	0
17	417	166.276	222.4	97	3	2	30	12	48	0
18	419	167.175	222.1	98	-16	2	30	12	48	0
19	14	193.091	222.3	99	10	2	30	12	48	1
20	12	0.000	180.0	100	6	3	30	12	48	0

SHOT NUMBER 12 SHOT POINT 11 TEAM 1
SHOT TIME: 312: 6: 2: 0.010

LOC	DIST(KM)	AZIM	UNIT	CHRON	CHAN	C1	C2	C3	TAPE	GRADE
1	381	134.615	160.8	1	3	2	30	12	48	0
2	382	135.013	160.9	2	-8	2	30	12	48	1
3	383	135.393	161.1	3	5	2	30	12	48	0
4	384	135.807	161.2	4	-32	2	30	12	48	0
5	385	136.183	161.4	5	7	2	30	12	48	0
6	386	136.563	161.5	6	2	1	30	12	48	0
7	387	136.967	161.6	7	-14	2	30	12	48	0
8	388	137.352	161.8	8	-19	2	30	12	48	0
9	389	137.846	161.9	9	17	2	30	12	48	0
10	390	138.389	162.0	10	26	2	30	12	48	0
11	391	138.939	162.1	11	14	2	30	12	48	0
12	392	139.528	162.1	12	0	1	30	12	48	0
13	393	140.072	162.2	13	-5	2	30	12	48	0
14	394	140.568	162.3	14	1	0	30	12	48	1
15	395	141.145	162.4	15	0	2	30	12	48	0
16	396	141.370	162.6	16	8	8	30	12	48	3
17	397	142.007	162.6	17	8	2	30	12	48	0
18	5	113.428	134.5	18	-15	2	30	12	88	0
19	6	114.097	126.2	19	-14	2	30	12	88	0
20	7	119.297	110.8	20	0	2	30	12	88	0

FIELD DATA TABLE

SHOT NUMBER 11 SHOT POINT 12 TEAM 6
SHOT TIME: 312: 6: 0: 0.006

LOC	DIST(KM)	AZIM	UNIT	CHRON	CHAN	C1	C2	C3	TAPE	GRADE
1	361	138.984	224.7	101	8	2	30	12	68	0
2	362	139.516	224.8	102	1	2	30	12	88	0
3	363	139.979	224.7	103	2	2	30	12	88	0
4	364	140.467	224.6	104	-3	2	30	12	88	0
5	365	140.850	224.5	105	4	2	30	12	88	2
6	366	141.295	224.4	106	-4	2	30	12	88	0
7	367	141.769	224.3	107	3	2	30	12	88	0
8	368	142.235	224.2	108	4	2	30	12	68	0
9	369	142.734	224.2	109	1	2	30	12	68	0
10	370	143.216	224.1	110	5	2	30	12	68	0
11	371	143.677	224.0	111	17	2	30	12	68	0
12	372	144.149	223.9	112	-3	2	30	12	68	0
13	373	144.630	223.8	113	4	2	30	12	88	0
14	374	145.088	223.8	114	0	2	30	12	88	0
15	375	145.600	223.7	115	2	2	30	12	88	0
16	376	146.008	223.6	116	0	2	30	12	88	0
17	377	146.516	223.6	117	4	2	30	12	68	0
18	378	146.971	223.5	118	-2	2	30	12	68	0
19	379	147.449	223.4	119	1	2	30	12	68	0
20	380	147.913	223.4	120	0	2	30	12	68	0

SHOT NUMBER 12 SHOT POINT 11 TEAM 2
SHOT TIME: 312: 6: 2: 0.010

LOC	DIST(KM)	AZIM	UNIT	CHRON	CHAN	C1	C2	C3	TAPE	GRADE
1	310	117.558	146.6	21	0	1	30	12	88	0
2	309	116.986	146.5	22	5	2	30	12	88	0
3	308	116.475	146.3	23	4	1	30	12	88	0
4	307	116.837	146.0	24	-9	2	30	12	48	0
5	306	116.911	145.7	25	0	2	30	12	48	0
6	305	116.585	145.5	26	5	2	30	12	48	0
7	304	116.653	145.2	27	0	2	30	12	48	0
8	303	116.435	145.0	28	-24	2	30	12	48	0
9	142	116.055	144.5	29	5	2	30	12	48	0
10	302	116.288	144.7	30	2	2	30	12	48	0
11	321	120.113	149.0	31	4	2	30	12	48	0
12	322	120.310	149.2	32	7	2	30	12	48	0
13	323	120.770	149.3	33	20	2	30	12	48	0
14	324	121.053	149.5	34	6	2	30	12	48	0
15	325	121.280	149.8	35	-19	1	30	12	48	0
16	326	121.573	149.9	36	0	2	30	12	48	0
17	327	121.805	150.2	37	4	2	30	12	48	2
18	328	121.706	150.4	38	3	2	30	12	48	0
19	329	121.857	150.7	39	1	2	30	12	48	0
20	330	122.048	150.9	40	3	2	30	12	88	0

FIELD DATA TABLE

SHOT NUMBER 12 SHOT POINT 11 TEAM 3
SHOT TIME: 312: 6: 2: 0.010

LOC	DIST(KM)	AZIM	UNIT	CHRON	CHAN	C1	C2	C3	TAPE	GRADE
1	341	124.242	41	13	2	30	12	48	0	0
2	342	124.372	42	1	2	30	12	48	0	0
3	343	124.501	43	2	30	12	48	3	3	0
4	344	124.616	44	9	2	30	12	48	0	0
5	345	124.754	45	0	30	12	48	3	3	0
6	346	124.879	46	10	1	30	12	48	0	0
7	347	125.015	47	16	2	30	12	48	0	0
8	348	125.174	48	-18	2	30	12	48	0	0
9	349	125.286	49	2	2	30	12	48	0	0
10	350	125.435	50	6	2	30	12	48	0	0
11	351	125.585	51	71	4	30	12	48	4	4
12	352	125.736	52	-4	2	30	12	48	0	0
13	353	125.882	53	3	2	30	12	48	0	0
14	354	126.038	54	3	2	30	12	48	0	0
15	355	126.172	55	-13	2	30	12	48	0	0
16	356	126.316	56	5	2	30	12	68	0	0
17	357	126.456	57	3	2	30	12	68	0	0
18	358	126.435	58	3	2	30	12	68	0	0
19	359	126.584	59	-2	2	30	12	68	0	0
20	360	126.947	60	-4	2	30	12	68	0	0

FIELD DATA TABLE

SHOT NUMBER 12 SHOT POINT 11 TEAM 5
SHOT TIME: 312: 6: 2: 0.010

LOC	DIST(KM)	AZIM	UNIT	CHRON	CHAN	C1	C2	C3	TAPE	GRADE
1	398	142.439	81	86	2	30	12	48	0	0
2	399	142.903	82	-6	2	30	12	48	0	0
3	400	143.324	83	9	30	12	68	2	2	0
4	401	143.502	84	-8	2	30	12	88	0	0
5	402	143.565	85	-11	2	30	12	88	0	0
6	403	143.770	86	0	2	30	12	88	0	0
7	404	144.033	87	-8	2	30	12	88	0	0
8	405	144.262	88	12	2	30	12	88	0	0
9	406	144.395	89	0	2	30	12	88	0	0
10	407	144.569	90	3	2	30	12	68	0	0
11	408	144.678	91	4	2	30	12	68	0	0
12	409	144.707	92	-2	2	30	12	68	0	0
13	410	145.009	93	-3	2	30	12	68	0	0
14	411	145.388	94	11	2	30	12	68	0	0
15	413	145.886	95	-19	2	30	12	48	0	0
16	415	146.169	96	1	2	30	12	48	0	0
17	417	146.209	97	3	2	30	12	48	0	0
18	419	147.226	98	-16	2	30	12	48	0	0
19	14	162.636	99	10	10	30	12	48	1	1
20	12	145.397	100	6	2	30	12	48	0	0

FIELD DATA TABLE

SHOT NUMBER 12 SHOT POINT 11 TEAM 4
SHOT TIME: 312: 6: 2: 0.010

LOC	DIST(KM)	AZIM	UNIT	CHRON	CHAN	C1	C2	C3	TAPE	GRADE
1	311	117.373	61	6	1	30	12	48	0	0
2	312	117.837	62	5	2	30	12	48	0	0
3	313	118.262	63	5	1	30	12	48	0	0
4	314	118.666	64	--	30	12	48	1	1	0
5	315	118.748	65	-18	30	12	48	2	2	0
6	316	118.080	66	3	2	30	12	48	0	0
7	317	118.563	67	0	2	30	12	48	0	0
8	318	119.176	68	-3	2	30	12	48	0	0
9	319	119.502	69	3	2	30	12	48	0	0
10	320	119.996	70	8	2	30	12	48	0	0
11	331	122.256	71	3	2	30	12	88	0	0
12	332	122.258	72	6	2	30	12	88	0	0
13	333	122.725	73	2	2	30	12	88	0	0
14	334	122.968	74	1	2	30	12	88	0	0
15	335	123.168	75	5	2	30	12	88	0	0
16	336	123.416	76	--	30	12	68	1	1	0
17	337	123.490	77	2	2	30	12	68	3	3
18	338	123.717	78	13	2	30	12	68	0	0
19	339	124.064	79	-64	2	30	12	68	0	0
20	340	124.193	80	3	2	30	12	68	0	0

FIELD DATA TABLE

SHOT NUMBER 12 SHOT POINT 11 TEAM 6
SHOT TIME: 312: 6: 2: 0.010

LOC	DIST(KM)	AZIM	UNIT	CHRON	CHAN	C1	C2	C3	TAPE	GRADE
1	361	127.175	101	8	2	30	12	68	0	0
2	362	127.276	102	1	2	30	12	88	0	0
3	363	127.645	103	2	2	30	12	88	0	0
4	364	128.036	104	-3	2	30	12	88	0	0
5	365	128.565	105	4	2	30	12	88	0	0
6	366	128.952	106	-4	2	30	12	88	0	0
7	367	129.323	107	3	2	30	12	88	0	0
8	368	129.707	108	4	2	30	12	68	0	0
9	369	130.075	109	1	2	30	12	68	0	0
10	370	130.464	110	5	2	30	12	68	0	0
11	371	130.850	111	17	2	30	12	68	0	0
12	372	131.256	112	-3	2	30	12	68	0	0
13	373	131.641	113	4	2	30	12	88	0	0
14	374	131.983	114	0	2	30	12	88	0	0
15	375	132.373	115	2	2	30	12	88	0	0
16	376	132.702	116	0	2	30	12	88	0	0
17	377	133.089	117	4	2	30	12	68	0	0
18	378	133.463	118	-2	2	30	12	68	0	0
19	379	133.850	119	1	2	30	12	68	0	0
20	380	134.225	120	0	2	30	12	68	0	0

FIELD DATA TABLE

SHOT NUMBER 13 SHOT POINT 14 TEAM 3
 SHOT TIME: 312: 6: 4: 0.008

LOC	DIST(KM)	AZIM	UNIT	CHRON	CHAN	C1	C2	C3	TAPE	GRADE
1	341	64.620	38.2	41	13	2	30	12	48	0
2	342	64.175	38.1	42	1	1	30	12	48	0
3	343	63.614	38.0	43	2	2	30	12	48	3
4	344	63.135	37.9	44	9	1	30	12	48	0
5	345	62.591	37.8	45	0	0	30	12	48	3
6	346	62.092	37.7	46	10	1	30	12	48	0
7	347	61.577	37.6	47	16	1	30	12	48	0
8	348	61.066	37.5	48	-18	1	30	12	48	0
9	349	60.579	37.4	49	2	1	30	12	48	0
10	350	60.052	37.3	50	6	1	30	12	48	0
11	351	59.520	37.2	51	71	1	30	12	48	4
12	352	59.022	37.1	52	-4	1	30	12	48	0
13	353	58.503	36.9	53	3	1	30	12	48	0
14	354	58.002	36.8	54	3	1	30	12	48	0
15	355	57.523	36.7	55	-13	1	30	12	48	0
16	356	56.996	36.6	56	5	1	30	12	68	0
17	357	56.513	36.5	57	3	2	30	12	68	0
18	358	56.007	36.1	58	5	2	30	12	68	0
19	359	55.526	36.0	59	-2	1	30	12	68	0
20	360	55.032	36.1	60	-4	2	30	12	68	0

FIELD DATA TABLE

SHOT NUMBER 13 SHOT POINT 14 TEAM 1
 SHOT TIME: 312: 6: 4: 0.008

LOC	DIST(KM)	AZIM	UNIT	CHRON	CHAN	C1	C2	C3	TAPE	GRADE
1	381	44.759	39.2	1	3	2	30	12	48	0
2	382	44.257	39.4	2	-8	0	30	12	48	1
3	383	43.783	39.6	3	5	2	30	12	48	0
4	384	43.272	39.9	4	-32	1	30	12	48	0
5	385	42.801	40.1	5	7	1	30	12	48	0
6	386	42.333	40.3	6	2	1	30	12	48	0
7	387	41.836	40.5	7	-14	1	30	12	48	0
8	388	41.360	40.7	8	-19	1	30	12	48	0
9	389	40.773	41.0	9	17	1	30	12	48	0
10	390	40.322	41.6	10	26	1	30	12	48	0
11	391	39.893	42.1	11	14	1	30	12	48	0
12	392	39.453	42.7	12	0	1	30	12	48	0
13	393	39.039	43.3	13	-5	1	30	12	48	0
14	394	38.621	43.8	14	1	1	30	12	48	1
15	395	38.174	44.4	15	0	1	30	12	48	0
16	396	37.681	44.4	16	8	8	30	12	48	3
17	397	37.308	45.2	17	8	1	30	12	48	0
18	5	104.725	38.3	18	-15	1	30	12	88	0
19	6	121.233	38.9	19	-15	3	30	12	88	3
20	7	153.006	38.7	20	0	0	30	12	88	3

FIELD DATA TABLE

SHOT NUMBER 13 SHOT POINT 14 TEAM 4
 SHOT TIME: 312: 6: 4: 0.008

LOC	DIST(KM)	AZIM	UNIT	CHRON	CHAN	C1	C2	C3	TAPE	GRADE
1	311	79.511	37.2	61	6	1	30	12	48	0
2	312	79.099	37.4	62	5	1	30	12	48	0
3	313	78.607	37.6	63	5	1	30	12	48	0
4	314	78.166	37.8	64	--	--	30	12	48	1
5	315	77.580	37.7	65	-18	3	30	12	48	2
6	316	76.989	37.0	66	3	1	30	12	48	0
7	317	76.516	37.3	67	0	1	30	12	48	0
8	318	76.061	37.6	68	-3	1	30	12	48	0
9	319	75.678	37.8	69	3	1	30	12	48	0
10	320	75.117	38.0	70	8	1	30	12	48	0
11	331	69.704	38.2	71	3	1	30	12	88	0
12	332	69.057	38.4	72	6	1	30	12	88	0
13	333	68.702	38.3	73	2	1	30	12	88	0
14	334	68.195	38.3	74	1	1	30	12	88	0
15	335	67.708	38.3	75	5	1	30	12	88	0
16	336	67.204	38.4	76	--	--	30	12	68	1
17	337	66.700	38.3	77	2	2	30	12	68	3
18	338	66.190	38.3	78	13	1	30	12	68	0
19	339	65.653	38.4	79	-64	1	30	12	68	0
20	340	65.146	38.3	80	3	1	30	12	68	0

FIELD DATA TABLE

SHOT NUMBER 13 SHOT POINT 14 TEAM 2
 SHOT TIME: 312: 6: 4: 0.008

LOC	DIST(KM)	AZIM	UNIT	CHRON	CHAN	C1	C2	C3	TAPE	GRADE
1	310	80.095	37.5	21	0	1	30	12	88	0
2	309	80.588	37.1	22	5	1	30	12	88	0
3	308	81.076	36.9	23	4	1	30	12	88	0
4	307	81.617	37.3	24	-5	1	30	12	48	0
5	306	82.149	37.5	25	-9	1	30	12	48	0
6	305	82.601	37.3	26	5	1	30	12	48	0
7	304	83.108	37.5	27	0	1	30	12	48	0
8	303	83.611	37.5	28	-24	1	30	12	48	0
9	142	84.624	37.4	29	5	1	30	12	48	0
10	302	84.139	37.5	30	2	1	30	12	48	0
11	321	74.605	38.0	31	4	1	30	12	48	0
12	322	74.174	38.0	32	7	1	30	12	48	0
13	323	73.681	38.2	33	20	1	30	12	48	0
14	324	73.181	38.3	34	6	1	30	12	48	0
15	325	72.700	38.4	35	-19	1	30	12	48	0
16	326	72.209	38.5	36	0	1	30	12	48	0
17	327	71.669	38.5	37	4	4	30	12	48	2
18	328	71.233	38.3	38	3	1	30	12	48	0
19	329	70.657	38.2	39	1	1	30	12	48	0
20	330	70.222	38.2	40	3	1	30	12	88	0

FIELD DATA TABLE

SHOT NUMBER 14 SHOT POINT 3 TEAM 1
 SHOT TIME: 312: 6: 6: 0.010

LOC	DIST(KM)	AZIM	UNIT	CHRON	CHAN	C1	C2	C3	TAPE	GRADE
1	381	24.344	217.2	1	3	2	30	12 48	0	0
2	382	24.852	216.9	2	-8	2	30	12 48	1	1
3	383	25.333	216.6	3	5	2	30	12 48	0	0
4	384	25.854	216.3	4	-32	2	30	12 48	0	0
5	385	26.335	216.0	5	7	2	30	12 48	0	0
6	386	26.814	215.7	6	2	2	30	12 48	0	0
7	387	27.324	215.5	7	-14	2	30	12 48	0	0
8	388	27.814	215.2	8	-19	2	30	12 48	0	0
9	389	28.421	214.9	9	17	2	30	12 48	0	0
10	390	28.913	214.3	10	26	2	30	12 48	0	0
11	391	29.392	213.7	11	14	2	30	12 48	0	0
12	392	29.895	213.0	12	0	2	30	12 48	0	0
13	393	30.374	212.4	13	-5	2	30	12 48	0	0
14	394	30.851	211.9	14	1	1	30	12 48	1	1
15	395	31.378	211.4	15	0	1	30	12 48	0	0
16	396	31.857	211.6	16	8	2	30	12 48	3	3
17	397	32.344	210.8	17	8	2	30	12 48	0	0
18	5	35.635	38.4	18	-15		30	12 88	2	2
19	6	52.149	39.9	19	-15		30	12 88	2	2
20	7	83.917	39.2	20	0		30	12 88	2	2

FIELD DATA TABLE

SHOT NUMBER 13 SHOT POINT 14 TEAM 5
 SHOT TIME: 312: 6: 4: 0.008

LOC	DIST(KM)	AZIM	UNIT	CHRON	CHAN	C1	C2	C3	TAPE	GRADE	
1	398	36.873	45.6	81	86	1	30	12 48	0	0	
2	399	36.431	46.1	82	-6	1	30	12 48	0	0	
3	400	35.962	46.4	83	9	1	30	12 68	2	2	
4	401	35.396	46.3	84	-8	1	30	12 88	0	0	
5	402	34.837	45.9	85	-11	1	30	12 88	0	0	
6	403	34.305	45.9	86	0	1	30	12 88	0	0	
7	404	33.968	46.1	87	-8	1	30	12 88	0	0	
8	405	33.297	45.9	88	12	1	30	12 88	0	0	
9	406	32.740	45.6	89	0	1	30	12 88	2	2	
10	407	32.183	45.4	90	3	1	30	12 68	0	0	
11	408	31.662	45.1	91	4	1	30	12 68	0	0	
12	409	31.109	44.6	92	-2	1	30	12 68	0	0	
13	410	30.599	44.7	93	-3	1	30	12 68	0	0	
14	411	30.106	45.0	94	11	1	30	12 68	0	0	
15	413	29.068	44.9	95	-19	1	30	12 48	0	0	
16	415	27.913	44.2	96	1	1	30	12 48	0	0	
17	417	26.820	42.8	97	3	1	30	12 48	0	0	
18	419	25.945	44.2	98	-16	3	30	12 48	0	0	
19	14	0.000	180.0	99	10	6	2	30	12 48	1	1
20	12	193.091	41.7	100	6	2	30	12 88	0	0	

FIELD DATA TABLE

SHOT NUMBER 14 SHOT POINT 3 TEAM 2
 SHOT TIME: 312: 6: 6: 0.010

LOC	DIST(KM)	AZIM	UNIT	CHRON	CHAN	C1	C2	C3	TAPE	GRADE
1	310	11.074	31.7	21	0	2	30	12 88	0	0
2	309	11.616	29.9	22	5	2	30	12 88	0	0
3	308	12.150	28.4	23	4	2	30	12 88	0	0
4	307	12.613	31.4	24	-5	1	30	12 48	0	0
5	306	13.118	32.7	25	-9	2	30	12 48	0	0
6	305	13.585	32.1	26	5	2	30	12 48	0	0
7	304	14.071	33.3	27	0	2	30	12 48	0	0
8	303	14.577	33.1	28	-24	2	30	12 48	0	0
9	142	15.593	33.1	29	5	2	30	12 48	0	0
10	302	15.103	33.3	30	2	2	30	12 48	0	0
11	321	5.542	32.8	31	4	1	30	12 48	0	0
12	322	5.109	32.8	32	7	1	30	12 48	0	0
13	323	4.537	36.0	33	20	3	30	12 48	0	0
14	324	4.052	37.2	34	6	1	30	12 48	0	0
15	325	3.611	37.3	35	-19	3	30	12 48	0	0
16	326	3.120	40.0	36	0	3	30	12 48	0	0
17	327	2.581	41.0	37	4	3	30	12 48	2	2
18	328	2.149	33.9	38	3	3	30	12 48	0	0
19	329	1.586	29.6	39	1	3	30	12 48	0	0
20	330	1.153	27.5	40	3	3	30	12 88	0	0

FIELD DATA TABLE

SHOT NUMBER 13 SHOT POINT 14 TEAM 6
 SHOT TIME: 312: 6: 4: 0.008

LOC	DIST(KM)	AZIM	UNIT	CHRON	CHAN	C1	C2	C3	TAPE	GRADE
1	361	54.477	36.1	101	6	1	30	12 68	0	0
2	362	53.969	35.9	102	1	2	30	12 88	0	0
3	363	53.483	36.0	103	2	2	30	12 88	0	0
4	364	52.971	36.1	104	-3	2	30	12 88	0	0
5	365	52.538	36.5	105	4	2	30	12 88	0	0
6	366	52.070	36.7	106	-4	1	30	12 88	0	0
7	367	51.577	36.8	107	3	1	30	12 88	0	0
8	368	51.091	37.0	108	4	1	30	12 68	0	0
9	369	50.577	37.1	109	1	1	30	12 68	0	0
10	370	50.076	37.3	110	5	1	30	12 68	0	0
11	371	49.597	37.5	111	17	1	30	12 68	0	0
12	372	49.106	37.7	112	-3	1	30	12 68	0	0
13	373	48.609	37.9	113	4	1	30	12 88	0	0
14	374	48.140	38.0	114	0	1	30	12 88	0	0
15	375	47.614	38.1	115	2	1	30	12 88	0	0
16	376	47.195	38.3	116	0	1	30	12 88	0	0
17	377	46.675	38.5	117	4	1	30	12 68	0	0
18	378	46.208	38.6	118	-2	1	30	12 68	0	0
19	379	45.719	38.8	119	1	1	30	12 68	0	0
20	380	45.244	39.0	120	0	2	30	12 68	0	0

FIELD DATA TABLE

SHOT NUMBER 14 SHOT POINT 3 TEAM 5
 SHOT TIME: 312: 6: 0.010

LOC	DIST(KM)	AZIM	UNIT	CHRON	CHAN	C1	C2	C3	TAPE	GRADE
1	398	210.6	81	86	2	30	12	48	2	0
2	399	210.3	82	-6	2	30	12	48	0	0
3	400	210.2	83	9	2	30	12	68	2	0
4	401	210.6	84	-8	2	30	12	88	0	0
5	402	211.2	85	-11	2	30	12	88	0	0
6	403	211.5	86	0	2	30	12	88	0	0
7	404	211.4	87	-8	2	30	12	88	0	0
8	405	211.8	88	12	2	30	12	88	0	0
9	406	212.3	89	0	2	30	12	88	0	0
10	407	212.6	90	3	2	30	12	68	0	0
11	408	213.0	91	4	2	30	12	68	0	0
12	409	213.6	92	-2	2	30	12	68	0	0
13	410	213.7	93	-3	2	30	12	68	0	0
14	411	213.6	94	11	2	30	12	68	0	0
15	413	214.0	95	-19	2	30	12	48	0	0
16	415	214.8	96	1	2	30	12	48	0	0
17	417	215.9	97	3	2	30	12	48	0	0
18	419	215.2	98	-16	2	30	12	48	0	0
19	14	218.7	99	10	2	30	12	48	1	0
20	12	43.8	100	6	2	30	12	48	0	0

FIELD DATA TABLE

SHOT NUMBER 14 SHOT POINT 3 TEAM 3
 SHOT TIME: 312: 6: 0.010

LOC	DIST(KM)	AZIM	UNIT	CHRON	CHAN	C1	C2	C3	TAPE	GRADE
1	341	222.4	41	13	3	30	12	48	0	0
2	342	222.9	42	1	3	30	12	48	0	0
3	343	223.7	43	2	3	30	12	48	0	0
4	344	224.2	44	9	1	30	12	48	0	0
5	345	224.7	45	0	3	30	12	48	0	0
6	346	225.1	46	10	1	30	12	48	0	0
7	347	225.5	47	16	1	30	12	48	0	0
8	348	225.6	48	-18	1	30	12	48	0	0
9	349	226.0	49	2	1	30	12	48	0	0
10	350	226.2	50	6	1	30	12	48	0	0
11	351	226.4	51	71	1	30	12	48	4	0
12	352	226.5	52	-4	1	30	12	48	0	0
13	353	226.7	53	3	1	30	12	48	0	0
14	354	226.8	54	3	2	30	12	48	0	0
15	355	227.0	55	-13	2	30	12	48	0	0
16	356	227.2	56	5	2	30	12	68	0	0
17	357	227.3	57	3	2	30	12	68	0	0
18	358	228.3	58	5	2	30	12	68	0	0
19	359	228.4	59	-2	2	30	12	68	0	0
20	360	227.5	60	-4	2	30	12	68	0	0

FIELD DATA TABLE

SHOT NUMBER 14 SHOT POINT 3 TEAM 6
 SHOT TIME: 312: 6: 0.010

LOC	DIST(KM)	AZIM	UNIT	CHRON	CHAN	C1	C2	C3	TAPE	GRADE
1	361	227.3	101	8	2	30	12	68	0	0
2	362	227.7	102	1	2	30	12	88	0	0
3	363	226.9	103	2	2	30	12	88	0	0
4	364	226.1	104	-3	2	30	12	88	0	0
5	365	224.6	105	4	2	30	12	88	0	0
6	366	223.9	106	-4	2	30	12	88	0	0
7	367	223.3	107	3	2	30	12	88	0	0
8	368	222.6	108	4	1	30	12	68	0	0
9	369	222.2	109	1	2	30	12	68	0	0
10	370	221.6	110	5	1	30	12	68	0	0
11	371	221.0	111	17	1	30	12	68	0	0
12	372	220.5	112	-3	2	30	12	63	0	0
13	373	220.0	113	4	2	30	12	88	0	0
14	374	219.7	114	0	2	30	12	88	0	0
15	375	219.3	115	2	2	30	12	88	0	0
16	376	218.9	116	0	2	30	12	88	0	0
17	377	218.6	117	4	2	30	12	68	0	0
18	378	218.2	118	-2	2	30	12	68	0	0
19	379	217.9	119	1	2	30	12	68	0	0
20	380	217.5	120	0	2	30	12	68	0	0

FIELD DATA TABLE

SHOT NUMBER 14 SHOT POINT 3 TEAM 4
 SHOT TIME: 312: 6: 0.010

LOC	DIST(KM)	AZIM	UNIT	CHRON	CHAN	C1	C2	C3	TAPE	GRADE
1	311	29.2	61	6	2	30	12	48	0	0
2	312	30.8	62	5	2	30	12	48	0	0
3	313	32.1	63	5	1	30	12	48	0	0
4	314	33.5	64	--	--	30	12	48	0	0
5	315	32.4	65	-18	3	30	12	48	2	0
6	316	25.4	66	3	1	30	12	48	0	0
7	317	27.1	67	0	1	30	12	48	0	0
8	318	30.3	68	-3	1	30	12	48	0	0
9	319	31.6	69	3	1	30	12	48	0	0
10	320	33.9	70	8	1	30	12	48	0	0
11	331	19.5	71	3	3	30	12	88	0	0
12	332	180.0	72	6	1	30	12	88	0	0
13	333	237.1	73	2	3	30	12	88	0	0
14	334	224.0	74	1	3	30	12	88	0	0
15	335	221.9	75	5	1	30	12	88	0	0
16	336	219.5	76	--	--	30	12	88	1	0
17	337	222.7	77	2	3	30	12	48	3	0
18	338	221.6	78	15	3	30	12	68	0	0
19	339	219.9	79	-54	3	30	12	68	3	0
20	340	220.2	80	3	1	30	12	68	0	0

FIELD DATA TABLE

SHOT NUMBER 15 SHOT POINT 2 TEAM 1
 SHOT TIME: 312: 6: 8: 0.013

LOC	DIST(KM)	AZIM	UNIT	CHRON	CHAN	C1	C2	C3	TAPE	GRADE
1	361	8.573	200.4	1	3	2	30	12	48	0
2	382	9.099	200.5	2	-8		30	12	48	1
3	383	9.597	200.6	3	5	2	30	12	48	0
4	384	10.137	200.6	4	-32	2	30	12	48	0
5	385	10.633	200.7	5	7	1	30	12	48	0
6	386	11.126	200.7	6	2	1	30	12	48	0
7	387	11.652	200.8	7	-14	1	30	12	48	0
8	388	12.154	200.8	8	-19	1	30	12	48	0
9	389	12.783	200.8	9	17	2	30	12	48	0
10	390	13.334	200.0	10	26	1	30	12	48	0
11	391	13.878	199.2	11	14	1	30	12	48	0
12	392	14.452	198.3	12	0	1	30	12	48	0
13	393	14.994	197.6	13	-5	1	30	12	48	0
14	394	15.518	197.2	14	1	1	30	12	48	1
15	395	16.105	196.6	15	0	1	30	12	48	0
16	396	16.538	197.4	16	8	3	30	12	48	3
17	397	17.114	196.5	17	8	1	30	12	48	0
18	5	51.859	40.7	18	-15	2	30	12	88	0
19	6	68.401	41.2	19	-15	2	30	12	88	0
20	7	100.145	40.2	20	0	2	30	12	88	0

FIELD DATA TABLE

SHOT NUMBER 15 SHOT POINT 2 TEAM 3
 SHOT TIME: 312: 6: 8: 0.013

LOC	DIST(KM)	AZIM	UNIT	CHRON	CHAN	C1	C2	C3	TAPE	GRADE
1	341	11.851	47.1	41	13	1	30	12	48	0
2	342	11.380	47.1	42	1	1	30	12	48	0
3	343	10.828	46.9	43	2		30	12	48	3
4	344	10.338	46.8	44	3	1	30	12	48	0
5	345	9.783	46.6	45	0		30	12	48	3
6	346	9.274	46.4	46	10	1	30	12	48	0
7	347	8.747	46.2	47	16	1	30	12	48	0
8	348	8.229	46.1	48	-18	1	30	12	48	0
9	349	7.728	45.7	49	2	3	30	12	48	0
10	350	7.192	45.4	50	6	1	30	12	48	0
11	351	6.649	45.0	51	71	1	30	12	48	4
12	352	6.142	44.7	52	-4	3	30	12	48	0
13	353	5.612	44.2	53	3	3	30	12	48	0
14	354	5.102	43.8	54	3	3	30	12	48	0
15	355	4.613	43.0	55	-13	3	30	12	48	0
16	356	4.075	41.9	56	5	3	30	12	68	0
17	357	3.584	40.6	57	3	3	30	12	68	0
18	358	3.069	35.2	58	5	3	30	12	68	0
19	359	2.594	32.4	59	-2	3	30	12	68	0
20	360	2.094	34.9	60	-4	3	30	12	68	0

FIELD DATA TABLE

SHOT NUMBER 15 SHOT POINT 2 TEAM 2
 SHOT TIME: 312: 6: 8: 0.013

LOC	DIST(KM)	AZIM	UNIT	CHRON	CHAN	C1	C2	C3	TAPE	GRADE
1	310	27.194	40.1	21	0	1	30	12	88	0
2	309	27.671	39.2	22	5	1	30	12	88	0
3	308	28.148	38.4	23	4	1	30	12	88	0
4	307	28.705	39.5	24	-5	1	30	12	48	0
5	306	29.247	40.0	25	-9	2	30	12	48	0
6	305	29.691	39.5	26	5	2	30	12	48	0
7	304	30.207	40.0	27	0	2	30	12	48	0
8	303	30.707	39.8	28	-24	2	30	12	48	0
9	142	31.716	39.6	29	5	2	30	12	48	0
10	302	31.235	39.8	30	2	2	30	12	48	0
11	321	21.755	42.5	31	4	1	30	12	48	0
12	322	21.328	42.7	32	7	1	30	12	48	0
13	323	20.863	43.6	33	20	2	30	12	48	0
14	324	20.374	44.1	34	6	1	30	12	48	0
15	325	19.902	44.4	35	-19	1	30	12	48	0
16	326	19.426	44.9	36	0	1	30	12	48	0
17	327	18.953	45.1	37	3	1	30	12	48	2
18	328	18.428	41.4	38	3	2	30	12	48	0
19	329	17.848	41.4	39	1	2	30	12	48	0
20	330	17.418	41.6	40	3	1	30	12	88	0

FIELD DATA TABLE

SHOT NUMBER 15 SHOT POINT 2 TEAM 4
 SHOT TIME: 312: 6: 8: 0.013

LOC	DIST(KM)	AZIM	UNIT	CHRON	CHAN	C1	C2	C3	TAPE	GRADE
1	311	26.595	39.3	61	6	2	30	12	48	0
2	312	26.136	40.1	62	5	2	30	12	48	0
3	313	25.719	40.7	63	5	2	30	12	48	0
4	314	25.292	41.4	64	--		30	12	48	1
5	315	24.700	41.2	65	-18		30	12	48	2
6	316	24.068	39.0	66	3	1	30	12	48	0
7	317	23.608	39.9	67	0	1	30	12	48	0
8	318	23.178	41.1	68	-3	1	30	12	48	0
9	319	22.808	41.7	69	3	1	30	12	48	0
10	320	22.270	42.6	70	8	1	30	12	48	0
11	331	16.905	44.8	71	3	1	30	12	88	0
12	332	16.291	45.9	72	6	1	30	12	88	0
13	333	15.919	45.5	73	2	1	30	12	88	0
14	334	15.421	45.9	74	1	1	30	12	88	0
15	335	14.940	46.2	75	5	1	30	12	88	0
16	336	14.447	46.6	76	--		30	12	68	1
17	337	13.928	46.4	77	2	1	30	12	68	3
18	338	13.425	46.7	78	13	1	30	12	68	0
19	339	12.916	47.7	79	-64		30	12	68	3
20	340	12.401	47.6	80	3	1	30	12	68	0

FIELD DATA TABLE

SHOT NUMBER 15 SHOT POINT 2 TEAM 5
 SHOT TIME: 312: 6: 8: 0.015

LOC	DIST(KM)	AZIM	UNIT	CHRON	CHAN	C1	C2	C3	TAPE	GRADE
1	398	17.621	196.4	81	87	1	30	12 48	0	0
2	399	18.191	196.3	82	-6	1	30	12 48	1	1
3	400	18.675	196.4	83	3	3	30	12 68	2	2
4	401	19.124	197.5	84	-8	1	30	12 88	0	0
5	402	19.515	198.8	85	-11	2	30	12 88	0	0
6	403	19.967	199.6	86	0	1	30	12 88	0	0
7	404	20.323	199.8	87	-8	1	30	12 88	0	0
8	405	20.884	200.8	88	13	1	30	12 88	0	0
9	406	21.528	201.8	89	0	2	30	12 88	0	0
10	407	21.795	202.7	90	3	3	30	12 68	2	2
11	408	22.215	203.6	91	4	2	30	12 68	0	0
12	409	22.629	204.8	92	-2	1	30	12 68	0	0
13	410	23.126	205.1	93	-3	2	30	12 68	0	0
14	411	23.642	205.1	94	11	2	30	12 68	0	0
15	413	24.608	206.0	95	-19	2	30	12 48	0	0
16	415	25.594	207.7	96	1	2	30	12 48	0	0
17	417	26.479	209.7	97	3	1	30	12 48	0	0
18	419	27.488	208.8	98	-16	2	30	12 48	0	0
19	14	52.939	216.4	99	10	10	30	12 48	1	1
20	12	140.492	44.0	100	6	6	30	12 48	3	3

FIELD DATA TABLE

SHOT NUMBER 16 SHOT POINT 3 TEAM 1
 SHOT TIME: 312: 6:30: 0.011

LOC	DIST(KM)	AZIM	UNIT	CHRON	CHAN	C1	C2	C3	TAPE	GRADE
1	381	24.344	217.2	1	3	2	30	12 48	0	0
2	382	24.852	216.9	2	-8	1	30	12 48	1	1
3	383	25.333	216.6	3	5	2	30	12 48	0	0
4	384	25.854	216.3	4	-33	4	30	12 48	0	0
5	385	26.335	216.0	5	-7	2	30	12 48	0	0
6	386	26.814	215.7	6	2	2	30	12 48	0	0
7	387	27.324	215.5	7	-15	2	30	12 48	0	0
8	388	27.814	215.2	8	-20	2	30	12 48	0	0
9	389	28.421	214.9	9	17	2	30	12 48	0	0
10	390	28.913	214.3	10	26	2	30	12 48	0	0
11	391	29.392	213.7	11	-15	2	30	12 48	0	0
12	392	29.895	213.0	12	0	2	30	12 48	0	0
13	393	30.374	212.4	13	-5	2	30	12 48	0	0
14	394	30.851	211.9	14	1	1	30	12 48	1	1
15	395	31.378	211.4	15	0	2	30	12 48	0	0
16	396	31.857	211.6	16	8	8	30	12 48	3	3
17	397	32.344	210.8	17	4	2	30	12 48	0	0
18	5	35.635	38.4	18	-15	18	30	12 88	2	2
19	6	52.149	39.9	19	-15	19	30	12 88	2	2
20	7	83.917	39.2	20	0	0	30	12 88	2	2

FIELD DATA TABLE

SHOT NUMBER 16 SHOT POINT 3 TEAM 2
 SHOT TIME: 312: 6:30: 0.011

LOC	DIST(KM)	AZIM	UNIT	CHRON	CHAN	C1	C2	C3	TAPE	GRADE
1	310	11.074	31.7	21	0	2	30	12 88	0	0
2	309	11.616	29.9	22	5	2	30	12 88	0	0
3	308	12.150	28.4	23	4	2	30	12 88	0	0
4	307	12.613	31.4	24	-5	2	30	12 48	0	0
5	306	13.118	32.7	25	-10	2	30	12 48	0	0
6	305	13.585	32.1	26	5	2	30	12 48	0	0
7	304	14.071	33.3	27	0	2	30	12 48	0	0
8	303	14.577	33.1	28	-25	2	30	12 48	3	3
9	142	15.593	33.1	29	5	2	30	12 48	0	0
10	302	15.103	33.3	30	2	2	30	12 48	0	0
11	321	5.542	32.8	31	4	1	30	12 48	0	0
12	322	5.109	32.8	32	8	1	30	12 48	0	0
13	323	4.597	36.0	33	20	3	30	12 48	0	0
14	324	4.092	37.2	34	6	1	30	12 48	0	0
15	325	3.611	37.9	35	-20	3	30	12 48	0	0
16	326	3.120	40.0	36	0	3	30	12 48	0	0
17	327	2.581	41.0	37	4	3	30	12 48	2	2
18	328	2.149	33.9	38	3	3	30	12 48	0	0
19	329	1.586	29.6	39	1	3	30	12 48	0	0
20	330	1.153	27.5	40	3	3	30	12 88	0	0

FIELD DATA TABLE

SHOT NUMBER 15 SHOT POINT 2 TEAM 6
 SHOT TIME: 312: 6: 8: 0.013

LOC	DIST(KM)	AZIM	UNIT	CHRON	CHAN	C1	C2	C3	TAPE	GRADE
1	361	1.544	31.6	101	8	3	30	12 68	0	0
2	362	1.080	18.8	102	1	3	30	12 88	0	0
3	363	0.577	16.8	103	2	3	30	12 88	0	0
4	364	0.063	336.7	104	-3	3	30	12 88	0	0
5	365	0.492	179.9	105	4	3	30	12 88	0	0
6	366	0.984	188.6	106	-4	3	30	12 88	0	0
7	367	1.483	193.3	107	3	1	30	12 68	0	0
8	368	1.989	195.0	108	4	3	30	12 68	0	0
9	369	2.510	197.1	109	1	3	30	12 68	0	0
10	370	3.030	197.8	110	5	3	30	12 68	0	0
11	371	3.533	198.0	111	17	3	30	12 68	0	0
12	372	4.054	198.1	112	-3	1	30	12 68	0	0
13	373	4.571	198.5	113	4	1	30	12 88	0	0
14	374	5.050	199.1	114	0	1	30	12 88	0	0
15	375	5.590	199.6	115	2	1	30	12 88	0	0
16	376	6.028	199.7	116	0	1	30	12 88	0	0
17	377	6.563	200.1	117	4	1	30	12 68	0	0
18	378	7.054	200.2	118	-2	1	30	12 68	0	0
19	379	7.566	200.3	119	1	1	30	12 68	0	0
20	380	8.062	200.4	120	0	1	30	12 68	0	0

FIELD DATA TABLE

SHOT NUMBER 16 SHOT POINT 3 TEAM 5
 SHOT TIME: 5:30: 0.011

LOC	DIST(KM)	AZIM	UNIT	CHRON	CHAN	C1	C2	C3	TAPE	GRADE
1	398	32.831	210.6	81	8	2	30	12 48	0	0
2	399	33.337	210.3	82	-6	2	30	12 48	0	0
3	400	33.852	210.2	83	9	2	30	12 68	0	0
4	401	34.372	210.6	84	-9	2	30	12 88	0	0
5	402	34.853	211.2	85	-11	2	30	12 88	0	0
6	403	35.354	211.5	86	0	2	30	12 88	0	0
7	404	35.710	211.4	87	-8	2	30	12 88	0	0
8	405	36.335	211.8	88	13	2	30	12 88	0	0
9	406	36.840	212.3	89	0	2	30	12 88	0	0
10	407	37.356	212.6	90	3	2	30	12 68	0	0
11	408	37.829	213.0	91	4	2	30	12 68	0	0
12	409	38.311	213.6	92	-2	2	30	12 68	0	0
13	410	38.821	213.7	93	-3	2	30	12 68	0	0
14	411	39.335	213.6	94	11	2	30	12 68	0	0
15	413	40.346	214.0	95	-20	2	30	12 48	0	0
16	415	41.415	214.8	96	2	2	30	12 48	0	0
17	417	42.399	215.9	97	3	2	30	12 48	0	0
18	419	43.358	215.2	98	-16	2	30	12 48	0	0
19	14	62.090	218.7	99	11	1	30	12 48	1	3
20	12	124.181	43.8	100	6	2	30	12 48	3	3

FIELD DATA TABLE

SHOT NUMBER 16 SHOT POINT 3 TEAM 3
 SHOT TIME: 6:30: 0.011

LOC	DIST(KM)	AZIM	UNIT	CHRON	CHAN	C1	C2	C3	TAPE	GRADE
1	341	4.480	222.4	41	14	2	30	12 48	0	0
2	342	4.950	222.9	42	1	1	30	12 48	0	0
3	343	5.438	223.7	43	2	2	30	12 48	3	3
4	344	5.936	224.2	44	9	1	30	12 48	0	0
5	345	6.539	224.7	45	0	0	30	12 48	3	3
6	346	7.048	225.1	46	10	1	30	12 48	0	0
7	347	7.573	225.5	47	17	1	30	12 48	0	0
8	348	8.091	225.6	48	-19	1	30	12 48	0	0
9	349	8.591	226.0	49	2	2	30	12 48	0	0
10	350	9.128	226.2	50	6	1	30	12 48	0	0
11	351	9.672	226.4	51	73	3	30	12 48	4	4
12	352	10.180	226.5	52	-4	1	30	12 48	0	0
13	353	10.712	226.7	53	3	2	30	12 48	0	0
14	354	11.223	226.8	54	3	2	30	12 48	0	0
15	355	11.715	227.0	55	-13	2	30	12 68	0	0
16	356	12.258	227.2	56	5	2	30	12 68	0	0
17	357	12.755	227.3	57	3	2	30	12 68	0	0
18	358	13.315	228.3	58	5	2	30	12 68	0	0
19	359	13.810	228.4	59	-2	2	30	12 68	0	0
20	360	14.269	227.5	60	-4	2	30	12 68	0	0

FIELD DATA TABLE

SHOT NUMBER 16 SHOT POINT 3 TEAM 6
 SHOT TIME: 6:30: 0.011

LOC	DIST(KM)	AZIM	UNIT	CHRON	CHAN	C1	C2	C3	TAPE	GRADE
1	361	14.828	227.3	101	9	2	30	12 68	0	0
2	362	15.366	227.7	102	2	2	30	12 88	0	0
3	363	15.818	226.9	103	2	2	30	12 88	0	0
4	364	16.297	226.1	104	-3	2	30	12 88	0	0
5	365	16.671	224.6	105	4	2	30	12 88	0	0
6	366	17.114	223.9	106	-4	2	30	12 88	0	0
7	367	17.589	223.3	107	3	2	30	12 88	0	0
8	368	18.057	222.6	108	4	1	30	12 68	0	0
9	369	18.560	222.2	109	2	2	30	12 68	0	0
10	370	19.047	221.6	110	5	1	30	12 68	0	0
11	371	19.516	221.0	111	17	2	30	12 68	0	0
12	372	19.997	220.5	112	-3	2	30	12 68	0	0
13	373	20.489	220.0	113	4	2	30	12 88	0	0
14	374	20.954	219.7	114	4	2	30	12 88	0	0
15	375	21.477	219.3	115	2	2	30	12 88	0	0
16	376	21.895	218.9	116	0	1	30	12 68	0	0
17	377	22.414	218.6	117	4	1	30	12 68	0	0
18	378	22.883	218.2	118	-2	2	30	12 68	0	0
19	379	23.375	217.9	119	1	2	30	12 68	0	0
20	380	23.853	217.5	120	0	2	30	12 68	0	0

FIELD DATA TABLE

SHOT NUMBER 16 SHOT POINT 3 TEAM 4
 SHOT TIME: 6:30: 0.011

LOC	DIST(KM)	AZIM	UNIT	CHRON	CHAN	C1	C2	C3	TAPE	GRADE
1	311	10.545	23.2	61	6	2	30	12 48	0	0
2	312	10.091	30.8	62	5	2	30	12 48	0	0
3	313	9.573	32.1	63	5	2	30	12 48	0	0
4	314	9.108	33.5	64	--	--	30	12 48	1	1
5	315	8.536	32.4	65	-19	3	30	12 48	2	2
6	316	8.093	25.4	66	3	1	30	12 48	0	0
7	317	7.565	27.1	67	0	1	30	12 48	0	0
8	318	7.040	30.3	68	-3	1	30	12 48	0	0
9	319	6.635	31.6	69	3	1	30	12 48	0	0
10	320	6.046	33.9	70	3	1	30	12 48	0	0
11	331	0.650	19.5	71	3	3	30	12 88	0	0
12	332	0.041	180.0	72	6	3	30	12 88	0	0
13	333	0.409	237.1	73	2	3	30	12 88	0	0
14	334	0.839	224.0	74	1	3	30	12 88	0	0
15	335	1.384	221.9	75	6	3	30	12 88	0	0
16	336	1.887	219.5	76	--	--	30	12 68	1	1
17	337	2.397	222.7	77	2	2	30	12 68	3	3
18	338	2.904	221.6	78	1	1	30	12 68	0	0
19	339	3.437	219.3	79	-66	1	30	12 68	3	3
20	340	3.945	230.2	80	3	1	30	12 68	0	0

FIELD DATA TABLE

SHOT NUMBER 17 SHOT POINT 2 TEAM 3
SHOT TIME: 312: 6:34: 0.013

LOC	DIST(KM)	AZIM	UNIT	CHRON	CHAN	C1	C2	C3	TAPE	GRADE
1	341	47.1	14	1	30	12	48	0		
2	342	47.1	42	1	30	12	48	0		
3	343	46.9	43	2	30	12	48	3		
4	344	46.8	44	9	30	12	48	3		
5	345	46.6	45	0	30	12	48	0		
6	346	46.4	46	10	30	12	48	0		
7	347	46.2	47	17	30	12	48	0		
8	348	46.1	48	-19	30	12	48	0		
9	349	45.7	49	2	30	12	48	0		
10	350	45.4	50	6	30	12	48	0		
11	351	45.0	51	74	30	12	48	4		
12	352	44.7	52	-4	30	12	48	0		
13	353	44.2	53	3	30	12	48	0		
14	354	43.8	54	3	30	12	48	0		
15	355	43.0	55	-13	30	12	48	0		
16	356	41.9	56	5	30	12	68	0		
17	357	40.6	57	3	30	12	68	0		
18	358	35.2	58	5	30	12	68	0		
19	359	32.4	59	-2	30	12	68	0		
20	360	2.094	60	-4	30	12	68	0		

FIELD DATA TABLE

SHOT NUMBER 17 SHOT POINT 2 TEAM 1
SHOT TIME: 312: 6:34: 0.013

LOC	DIST(KM)	AZIM	UNIT	CHRON	CHAN	C1	C2	C3	TAPE	GRADE
1	361	200.4	1	3	2	30	12	48	0	
2	362	200.5	2	-8	2	30	12	48	1	
3	363	200.6	3	5	2	30	12	48	0	
4	364	200.6	4	-33	2	30	12	48	0	
5	365	200.7	5	-7	2	30	12	48	0	
6	366	200.7	6	2	2	30	12	48	0	
7	367	200.8	7	-15	2	30	12	48	0	
8	368	200.8	8	-20	2	30	12	48	0	
9	369	200.8	9	17	2	30	12	48	0	
10	370	200.0	10	26	2	30	12	48	0	
11	371	199.2	11	-15	2	30	12	48	0	
12	372	198.3	12	0	2	30	12	48	0	
13	373	197.6	13	-5	2	30	12	48	0	
14	374	197.2	14	1	2	30	12	48	1	
15	375	196.6	15	0	2	30	12	48	0	
16	376	197.4	16	8	2	30	12	48	3	
17	377	196.5	17	4	2	30	12	48	0	
18	378	40.7	18	-15	2	30	12	68	0	
19	379	41.2	19	-15	2	30	12	68	0	
20	380	40.2	20	0	2	30	12	68	0	

FIELD DATA TABLE

SHOT NUMBER 17 SHOT POINT 2 TEAM 4
SHOT TIME: 312: 6:34: 0.013

LOC	DIST(KM)	AZIM	UNIT	CHRON	CHAN	C1	C2	C3	TAPE	GRADE
1	311	39.3	61	6	2	30	12	48	0	
2	312	40.1	62	5	2	30	12	48	0	
3	313	40.7	63	5	2	30	12	48	0	
4	314	41.4	64	--	--	30	12	48	1	
5	315	41.2	65	-19	2	30	12	48	2	
6	316	39.9	66	3	2	30	12	48	0	
7	317	41.1	67	0	2	30	12	48	0	
8	318	41.7	68	-3	2	30	12	48	0	
9	319	42.6	69	3	2	30	12	48	0	
10	320	44.8	70	8	2	30	12	48	0	
11	321	44.8	71	3	2	30	12	88	0	
12	322	45.9	72	6	2	30	12	88	0	
13	323	45.5	73	2	2	30	12	88	0	
14	324	45.9	74	1	2	30	12	88	0	
15	325	46.2	75	6	2	30	12	88	0	
16	326	46.6	76	--	--	30	12	68	1	
17	327	46.4	77	2	2	30	12	68	3	
18	328	46.7	78	13	1	30	12	68	0	
19	329	47.7	79	-66	--	30	12	68	3	
20	330	47.6	80	3	1	30	12	68	0	

FIELD DATA TABLE

SHOT NUMBER 17 SHOT POINT 2 TEAM 2
SHOT TIME: 312: 6:34: 0.013

LOC	DIST(KM)	AZIM	UNIT	CHRON	CHAN	C1	C2	C3	TAPE	GRADE
1	310	40.1	21	0	2	30	12	88	0	
2	309	39.2	22	5	2	30	12	88	0	
3	308	38.4	23	4	2	30	12	88	0	
4	307	39.5	24	-5	2	30	12	48	0	
5	306	40.0	25	-10	2	30	12	48	0	
6	305	39.5	26	5	2	30	12	48	0	
7	304	40.0	27	0	2	30	12	48	0	
8	303	39.8	28	-25	2	30	12	48	3	
9	142	39.6	29	5	2	30	12	48	0	
10	302	39.8	30	2	2	30	12	48	0	
11	321	42.5	31	4	2	30	12	48	0	
12	322	42.7	32	8	2	30	12	48	0	
13	323	43.6	33	20	2	30	12	48	0	
14	324	44.1	34	6	2	30	12	48	0	
15	325	44.4	35	-20	2	30	12	48	0	
16	326	44.9	36	0	2	30	12	48	0	
17	327	45.1	37	4	2	30	12	48	2	
18	328	44.4	38	3	2	30	12	48	0	
19	329	44.4	39	1	2	30	12	48	0	
20	330	44.6	40	3	2	30	12	68	0	

FIELD DATA TABLE

SHOT NUMBER 17 SHOT POINT 2 TEAM 5
 SHOT TIME: 6:34: 0.013

LOC	DIST(KM)	AZIM	UNIT	CHRON	CHAN	C1	C2	C3	TAPE	GRADE
1	398	17.621	196.4	81	8	2	30	12	48	0
2	399	18.151	196.3	82	-6	2	30	12	48	0
3	400	18.675	196.4	83	9	2	30	12	68	0
4	401	19.124	197.5	84	-9	2	30	12	88	0
5	402	19.515	198.8	85	-11	2	30	12	88	0
6	403	19.967	199.6	86	0	2	30	12	88	0
7	404	20.323	199.8	87	-8	2	30	12	88	0
8	405	20.884	200.8	88	13	2	30	12	88	0
9	406	21.328	201.6	89	0	2	30	12	88	0
10	407	21.795	202.7	90	3	2	30	12	68	2
11	408	22.215	203.6	91	4	2	30	12	68	0
12	409	22.629	204.8	92	-2	2	30	12	68	0
13	410	23.126	205.1	93	-3	2	30	12	68	0
14	411	23.642	205.1	94	11	2	30	12	68	0
15	413	24.608	206.0	95	-20	2	30	12	48	0
16	415	25.594	207.7	96	2	2	30	12	48	0
17	417	26.479	209.7	97	3	2	30	12	48	0
18	419	27.488	208.8	98	-16	2	30	12	48	0
19	14	52.932	216.4	99	11		30	12	48	1
20	12	140.492	44.0	100	6		30	12	48	3

FIELD DATA TABLE

SHOT NUMBER 18 SHOT POINT 7 TEAM 1
 SHOT TIME: 9: 0: 0.007

LOC	DIST(KM)	AZIM	UNIT	CHRON	CHAN	C1	C2	C3	TAPE	GRADE
1	381	108.249	219.1	1	4	2	30	12	48	0
2	382	108.753	219.0	2	-10		30	12	48	1
3	383	109.230	218.9	3	6	2	30	12	48	0
4	384	109.745	218.9	4	-38	2	30	12	48	0
5	385	110.221	218.8	5	-8	2	30	12	48	0
6	386	110.694	218.7	6	3	2	30	12	48	0
7	387	111.197	218.6	7	-17	2	30	12	48	0
8	388	111.680	218.6	8	-23	2	30	12	48	0
9	389	112.278	218.5	9	20	2	30	12	48	0
10	390	112.750	218.3	10	31	2	30	12	48	0
11	391	113.207	218.1	11	-17	2	30	12	48	0
12	392	113.681	217.9	12	0	2	30	12	48	0
13	393	114.133	217.7	13	-6	2	30	12	48	0
14	394	114.586	217.6	14	1		30	12	48	1
15	395	115.081	217.4	15	0	2	30	12	48	0
16	396	115.569	217.5	16	9		30	12	48	3
17	397	116.012	217.2	17	5	1	30	12	48	0
18	5	48.289	220.2	18	-18	2	30	12	88	0
19	6	31.776	218.5	19	-17	1	30	12	88	0
20	7			20	-2		30	12	88	3

FIELD DATA TABLE

SHOT NUMBER 17 SHOT POINT 2 TEAM 6
 SHOT TIME: 6:34: 0.013

LOC	DIST(KM)	AZIM	UNIT	CHRON	CHAN	C1	C2	C3	TAPE	GRADE
1	361	1.544	31.6	101	9	3	30	12	68	0
2	362	1.080	18.8	102	2	1	30	12	88	6
3	363	0.577	16.8	103	2	1	30	12	88	6
4	364	0.063	336.7	104	-3	3	30	12	88	0
5	365	0.499	179.9	105	4	3	30	12	88	0
6	366	0.984	188.6	106	-4	1	30	12	88	0
7	367	1.483	193.3	107	3	1	30	12	88	0
8	368	1.989	195.0	108	4	1	30	12	68	0
9	362	2.510	197.1	109	2	3	30	12	68	0
10	370	3.030	197.8	110	5	1	30	12	68	0
11	371	3.533	198.0	111	17	3	30	12	68	0
12	372	4.054	198.1	112	-3	1	30	12	68	0
13	373	4.571	198.5	113	4	1	30	12	88	0
14	374	5.050	199.1	114	0	1	30	12	88	0
15	375	5.590	199.6	115	2	1	30	12	88	0
16	376	6.028	199.7	116	0	1	30	12	88	0
17	377	6.563	200.1	117	4	1	30	12	68	0
18	378	7.054	200.2	118	-2	1	30	12	68	0
19	379	7.566	200.3	119	1	1	30	12	68	0
20	390	9.052	200.4	120	0	1	30	12	68	0

FIELD DATA TABLE

SHOT NUMBER 18 SHOT POINT 7 TEAM 2
 SHOT TIME: 9: 0: 0.007

LOC	DIST(KM)	AZIM	UNIT	CHRON	CHAN	C1	C2	C3	TAPE	GRADE
1	310	72.951	220.7	21	1	2	30	12	88	0
2	309	72.480	221.0	22	6	2	30	12	88	0
3	308	72.017	221.4	23	5	1	30	12	88	0
4	307	71.443	220.9	24	-6	1	30	12	48	0
5	306	70.898	220.7	25	-11	2	30	12	48	0
6	305	70.457	220.9	26	6	2	30	12	48	0
7	304	69.938	220.8	27	0	2	30	12	48	0
8	303	69.439	220.8	28	-29	2	30	12	48	0
9	142	68.432	220.9	29	6	2	30	12	48	0
10	302	68.911	220.8	30	3	1	30	12	48	0
11	321	78.412	220.0	31	5	2	30	12	48	0
12	322	78.842	220.0	32	9	2	30	12	48	0
13	323	79.329	219.7	33	24	1	30	12	48	0
14	324	79.828	219.7	34	7	1	30	12	48	0
15	325	80.307	219.6	35	-23	1	30	12	48	0
16	326	80.797	219.5	36	0	1	30	12	48	0
17	327	81.337	219.5	37	5		30	12	48	2
18	328	81.777	219.7	38	4	2	30	12	48	0
19	329	82.353	219.7	39	2	2	30	12	48	0
20	330	82.788	219.7	40	4	2	30	12	88	0

FIELD DATA TABLE

SHOT NUMBER 18 SHOT POINT 7 TEAM 5
SHOT TIME: 312: 9: 0: 0.007

LOC	DIST(KM)	AZIM	UNIT	CHRON	CHAN	C1	C2	C3	TAPE	GRADE
1	398	116.481	81	10	1	30	12	48	0	0
2	399	116.965	82	-7	1	30	12	48	0	0
3	400	117.467	83	10	1	30	12	68	2	2
4	401	118.010	84	-10	1	30	12	88	0	0
5	402	118.525	85	-13	2	30	12	88	0	0
6	403	119.042	86	0	2	30	12	88	0	0
7	404	119.394	87	-9	2	30	12	88	0	0
8	405	120.041	88	15	2	30	12	88	0	0
9	406	120.568	89	0	2	30	12	88	0	0
10	407	121.102	90	4	4	30	12	68	2	2
11	408	121.594	91	5	1	30	12	68	0	0
12	409	122.103	92	-2	1	30	12	68	0	0
13	410	122.615	93	-3	2	30	12	68	0	0
14	411	123.125	94	13	2	30	12	68	0	0
15	413	124.148	95	-23	2	30	12	48	0	0
16	415	125.248	96	2	2	30	12	48	0	0
17	417	126.268	97	4	2	30	12	48	0	0
18	419	127.204	98	-19	2	30	12	48	0	0
19	14	153.005	99	12	12	30	12	48	1	1
20	12	41.095	100	7	2	30	12	48	0	0

FIELD DATA TABLE

SHOT NUMBER 18 SHOT POINT 7 TEAM 3
SHOT TIME: 312: 9: 0: 0.007

LOC	DIST(KM)	AZIM	UNIT	CHRON	CHAN	C1	C2	C3	TAPE	GRADE
1	341	88.390	41	16	1	30	12	48	0	0
2	342	88.857	42	1	2	30	12	48	0	0
3	343	89.400	43	2	2	30	12	48	3	3
4	344	89.881	44	11	1	30	12	48	0	0
5	345	90.428	45	0	0	30	12	48	3	3
6	346	90.930	46	12	2	30	12	48	0	0
7	347	91.449	47	20	1	30	12	48	0	0
8	348	91.962	48	-23	2	30	12	48	0	0
9	349	92.454	49	3	2	30	12	48	0	0
10	350	92.984	50	7	1	30	12	48	0	0
11	351	93.521	51	87	1	30	12	48	4	4
12	352	94.023	52	-5	1	30	12	48	0	0
13	353	94.547	53	3	1	30	12	48	0	0
14	354	95.053	54	4	1	30	12	48	0	0
15	355	95.538	55	-16	2	30	12	48	0	0
16	356	96.072	56	6	2	30	12	68	0	0
17	357	96.561	57	3	2	30	12	68	0	0
18	358	97.088	58	6	2	30	12	68	0	0
19	359	97.576	59	-3	2	30	12	68	0	0
20	360	98.060	60	-5	2	30	12	68	0	0

FIELD DATA TABLE

SHOT NUMBER 18 SHOT POINT 7 TEAM 6
SHOT TIME: 312: 9: 0: 0.007

LOC	DIST(KM)	AZIM	UNIT	CHRON	CHAN	C1	C2	C3	TAPE	GRADE
1	361	98.619	101	10	2	30	12	68	0	0
2	362	99.140	102	2	2	30	12	88	0	0
3	363	99.616	103	3	2	30	12	88	0	0
4	364	100.116	104	-3	2	30	12	88	0	0
5	365	100.525	105	4	2	30	12	88	0	0
6	366	100.984	106	-5	1	30	12	88	0	0
7	367	101.469	107	4	1	30	12	88	0	0
8	368	101.948	108	5	1	30	12	68	0	0
9	369	102.457	109	2	1	30	12	68	0	0
10	370	102.951	110	6	1	30	12	68	0	0
11	371	103.425	111	20	1	30	12	68	0	0
12	372	103.911	112	-3	2	30	12	68	0	0
13	373	104.404	113	5	2	30	12	88	0	0
14	374	104.871	114	0	2	30	12	88	0	0
15	375	105.394	115	2	2	30	12	88	0	0
16	376	105.812	116	0	2	30	12	88	0	0
17	377	106.330	117	5	1	30	12	68	0	0
18	378	106.798	118	-2	2	30	12	68	0	0
19	379	107.286	119	2	2	30	12	68	0	0
20	380	107.762	120	0	2	30	12	68	0	0

FIELD DATA TABLE

SHOT NUMBER 18 SHOT POINT 7 TEAM 4
SHOT TIME: 312: 9: 0: 0.007

LOC	DIST(KM)	AZIM	UNIT	CHRON	CHAN	C1	C2	C3	TAPE	GRADE
1	311	73.555	61	7	7	30	12	48	0	0
2	312	73.949	62	6	2	30	12	48	0	0
3	313	74.427	63	6	1	30	12	48	0	0
4	314	74.859	64	--	--	30	12	48	1	1
5	315	75.449	65	-22	2	30	12	48	2	2
6	316	76.084	66	4	2	30	12	48	0	0
7	317	76.538	67	0	2	30	12	48	0	0
8	318	76.970	68	-4	2	30	12	48	0	0
9	319	77.346	69	3	2	30	12	48	0	0
10	320	77.899	70	9	2	30	12	48	0	0
11	331	83.506	71	3	1	30	12	88	0	0
12	332	83.949	72	7	2	30	12	88	0	0
13	333	84.307	73	2	2	30	12	88	0	0
14	334	84.813	74	1	2	30	12	88	0	0
15	335	85.299	75	7	1	30	12	88	0	0
16	336	85.804	76	--	--	30	12	68	1	1
17	337	86.309	77	2	2	30	12	68	3	3
18	338	86.819	78	15	1	30	12	68	0	0
19	339	87.353	79	-7	3	30	12	68	3	3
20	340	87.861	80	9	3	30	12	68	3	3

FIELD DATA TABLE

SHOT NUMBER 19 SHOT POINT 1 TEAM 3
 SHOT TIME: 312: 9: 2: 0.006

LOC	DIST(KM)	AZIM	UNIT	CHRON	CHAN	C1	C2	C3	TAPE	GRADE
1	341	31.302	41	16	2	30	12	48	0	0
2	342	30.854	42	1	1	30	12	48	0	0
3	343	30.339	43	2	1	30	12	48	3	3
4	344	29.883	44	11	1	30	12	48	0	0
5	345	29.365	45	0	1	30	12	48	3	3
6	346	28.893	46	12	1	30	12	48	0	0
7	347	28.405	47	20	1	30	12	48	0	0
8	348	27.917	48	-23	1	30	12	48	0	0
9	349	27.463	49	3	1	30	12	48	0	0
10	350	26.968	50	7	1	30	12	48	0	0
11	351	26.469	51	87	1	30	12	48	4	4
12	352	26.001	52	-5	1	30	12	48	0	0
13	353	25.519	53	3	1	30	12	48	0	0
14	354	25.052	54	4	1	30	12	48	0	0
15	355	24.612	55	-16	2	30	12	48	0	0
16	356	24.130	56	6	2	30	12	68	0	0
17	357	23.690	57	3	2	30	12	68	0	0
18	358	23.280	58	6	2	30	12	68	0	0
19	359	22.846	59	-3	1	30	12	68	0	0
20	360	22.337	60	-5	2	30	12	68	0	0

FIELD DATA TABLE

SHOT NUMBER 19 SHOT POINT 1 TEAM 1
 SHOT TIME: 312: 9: 2: 0.006

LOC	DIST(KM)	AZIM	UNIT	CHRON	CHAN	C1	C2	C3	TAPE	GRADE
1	381	11.733	18.9	1	4	1	30	12	48	0
2	382	11.214	18.8	2	-10	1	30	12	48	1
3	383	10.716	18.7	3	6	1	30	12	48	0
4	384	10.177	18.5	4	-38	1	30	12	48	0
5	385	9.682	18.4	5	-8	1	30	12	48	0
6	386	9.189	18.2	6	3	1	30	12	48	0
7	387	8.664	18.0	7	-17	1	30	12	48	0
8	388	8.163	17.7	8	-23	1	30	12	48	0
9	389	7.535	17.5	9	20	1	30	12	48	0
10	390	6.977	18.8	10	31	3	30	12	48	0
11	391	6.433	20.4	11	-17	3	30	12	48	0
12	392	5.870	22.7	12	0	3	30	12	48	0
13	393	5.349	25.0	13	-6	1	30	12	48	0
14	394	4.849	27.2	14	1	1	30	12	48	1
15	395	4.309	30.7	15	0	3	30	12	48	0
16	396	3.834	28.8	16	9	3	30	12	48	3
17	397	3.354	35.7	17	5	3	30	12	48	0
18	5	71.186	34.7	18	-18	2	30	12	88	0
19	6	87.601	36.3	19	-17	2	30	12	88	0
20	7	113.366	36.8	20	-2	2	30	12	88	0

FIELD DATA TABLE

SHOT NUMBER 19 SHOT POINT 1 TEAM 4
 SHOT TIME: 312: 9: 2: 0.006

LOC	DIST(KM)	AZIM	UNIT	CHRON	CHAN	C1	C2	C3	TAPE	GRADE
1	311	46.226	30.7	61	7	2	30	12	48	0
2	312	45.778	31.1	62	6	2	30	12	48	0
3	313	45.259	31.4	63	6	2	30	12	48	0
4	314	44.790	31.7	64	--		30	12	48	1
5	315	44.221	31.4	65	-22		30	12	48	2
6	316	43.744	30.1	66	4	2	30	12	48	0
7	317	43.235	30.5	67	0	2	30	12	48	0
8	318	42.726	31.0	68	-4	2	30	12	48	0
9	319	42.322	31.2	69	3	2	30	12	48	0
10	320	41.728	31.6	70	9	2	30	12	48	0
11	321	36.323	31.0	71	3	3	30	12	88	0
12	322	35.651	31.2	72	7	1	30	12	88	0
13	323	35.319	30.9	73	2	1	30	12	88	0
14	324	34.810	30.9	74	1	1	30	12	88	0
15	325	34.327	30.8	75	7	1	30	12	88	0
16	326	33.820	30.7	76	--		30	12	68	1
17	327	33.341	30.4	77	2		30	12	68	3
18	328	32.834	30.3	78	15	1	30	12	68	0
19	329	32.283	30.4	79	-77		30	12	68	3
20	340	31.795	30.1	80	3		30	12	68	3

FIELD DATA TABLE

SHOT NUMBER 19 SHOT POINT 1 TEAM 2
 SHOT TIME: 312: 9: 2: 0.006

LOC	DIST(KM)	AZIM	UNIT	CHRON	CHAN	C1	C2	C3	TAPE	GRADE
1	310	46.761	31.3	21	1	2	30	12	88	0
2	309	47.300	30.8	22	6	2	30	12	88	0
3	308	47.826	30.5	23	5	2	30	12	88	0
4	307	48.300	31.2	24	-6	2	30	12	48	0
5	306	48.802	31.6	25	-11	2	30	12	48	0
6	305	49.271	31.4	26	6	2	30	12	48	0
7	304	49.751	31.8	27	0	2	30	12	48	0
8	303	50.259	31.7	28	-29	2	30	12	48	0
9	142	51.274	31.8	29	6	2	30	12	48	0
10	302	50.783	31.8	30	3	2	30	12	48	0
11	321	41.227	31.4	31	5	2	30	12	48	0
12	322	40.734	31.4	32	9	2	30	12	48	0
13	323	40.269	31.7	33	24	2	30	12	48	0
14	324	39.760	31.8	34	7	2	30	12	48	0
15	325	39.276	31.8	35	-23	1	30	12	48	0
16	326	38.774	31.9	36	0	1	30	12	48	0
17	327	38.233	31.9	37	5	1	30	12	48	2
18	328	37.634	31.4	38	4	2	30	12	48	0
19	329	37.272	31.1	39	2	2	30	12	48	0
20	330	36.838	31.1	40	4	2	30	12	68	0

FIELD DATA TABLE

SHOT NUMBER 20 SHOT POINT 4 TEAM 1
SHOT TIME: 312: 9: 4: 0.010

LOC	DIST(KM)	AZIM	UNIT	CHRON	CHAN	C1	C2	C3	TAPE	GRADE
1	381	40.057	215.6	1	4	2	30	12	48	0
2	382	40.568	215.5	2	-10		30	12	48	1
3	383	41.053	215.3	3	6	2	30	12	48	0
4	384	41.577	215.1	4	-38	2	30	12	48	0
5	385	42.060	215.0	5	8	2	30	12	48	0
6	386	42.541	214.8	6	3	2	30	12	48	0
7	387	43.054	214.7	7	-17	2	30	12	48	0
8	388	43.544	214.5	8	-23	2	30	12	48	0
9	389	44.154	214.3	9	20	2	30	12	48	0
10	390	44.648	213.9	10	31	2	30	12	48	0
11	391	45.129	213.5	11	17	2	30	12	48	0
12	392	45.632	213.1	12	0	2	30	12	48	0
13	393	46.111	212.7	13	-6	2	30	12	48	0
14	394	46.587	212.4	14	1	2	30	12	48	1
15	395	47.111	212.0	15	0	2	30	12	48	0
16	396	47.591	212.1	16	9	2	30	12	48	3
17	397	48.074	211.6	17	5	2	30	12	48	0
18	5	20.018	42.6	18	-18	2	30	12	88	0
19	6	36.570	42.8	19	-17	2	30	12	88	0
20	7	68.291	40.7	20	-2	2	30	12	88	0

FIELD DATA TABLE

SHOT NUMBER 19 SHOT POINT 1 TEAM 5
SHOT TIME: 312: 9: 2: 0.006

LOC	DIST(KM)	AZIM	UNIT	CHRON	CHAN	C1	C2	C3	TAPE	GRADE
1	398	2.887	39.3	81	10	3	30	12	48	0
2	399	2.426	45.0	82	-7	3	30	12	48	0
3	400	1.965	51.6	83	10	3	30	12	68	2
4	401	1.393	50.1	84	-10	3	30	12	88	0
5	402	0.840	37.9	85	-13	3	30	12	88	0
6	403	0.343	16.9	86	0	3	30	12	88	0
7	404	0.060	277.6	87	-9	3	30	12	88	0
8	405	0.722	237.5	88	15	3	30	12	88	0
9	406	1.299	239.1	89	0	3	30	12	88	0
10	407	1.865	238.4	90	4	3	30	12	68	2
11	408	2.413	239.5	91	5	3	30	12	68	0
12	409	3.021	242.1	92	-2	3	30	12	68	0
13	410	3.499	238.8	93	-3	3	30	12	68	0
14	411	3.951	235.0	94	13	3	30	12	68	0
15	413	4.981	233.3	95	-23	1	30	12	48	0
16	415	6.182	235.1	96	2	1	30	12	48	0
17	417	7.395	238.4	97	4	1	30	12	48	0
18	419	8.122	232.4	98	-19	1	30	12	48	0
19	14	34.006	226.3	99	12	2	30	12	48	1
20	12	159.207	40.9	100	7	2	30	12	48	0

FIELD DATA TABLE

SHOT NUMBER 20 SHOT POINT 4 TEAM 2
SHOT TIME: 312: 9: 4: 0.010

LOC	DIST(KM)	AZIM	UNIT	CHRON	CHAN	C1	C2	C3	TAPE	GRADE
1	310	4.673	216.3	21	1	3	30	12	88	0
2	309	4.191	222.0	22	6	1	30	12	88	0
3	308	3.758	228.3	23	5	3	30	12	88	0
4	307	3.152	219.9	24	-6	3	30	12	48	0
5	306	2.620	214.8	25	-11	3	30	12	48	0
6	305	2.167	219.3	26	6	3	30	12	48	0
7	304	1.668	211.6	27	0	3	30	12	48	0
8	303	1.160	212.2	28	-29	3	30	12	48	0
9	142	0.146	205.5	29	6	3	30	12	48	0
10	302	0.639	206.6	30	3	3	30	12	48	0
11	321	10.195	213.3	31	5	1	30	12	48	0
12	322	10.629	213.2	32	9	1	30	12	48	0
13	323	11.150	211.9	33	24	1	30	12	48	0
14	324	11.660	211.7	34	7	1	30	12	48	0
15	325	12.193	211.7	35	-23	1	30	12	48	0
16	326	12.646	211.4	36	0	1	30	12	48	0
17	327	13.186	211.6	37	5	5	30	12	48	2
18	328	13.588	213.0	38	4	2	30	12	48	0
19	329	14.155	213.5	39	2	1	30	12	48	0
20	330	14.590	213.6	40	4	1	30	12	88	0

FIELD DATA TABLE

SHOT NUMBER 19 SHOT POINT 1 TEAM 6
SHOT TIME: 312: 9: 2: 0.006

LOC	DIST(KM)	AZIM	UNIT	CHRON	CHAN	C1	C2	C3	TAPE	GRADE
1	361	21.823	20.4	101	10	1	30	12	68	0
2	362	21.390	19.5	102	12	2	30	12	88	0
3	363	20.887	19.5	103	3	1	30	12	88	0
4	364	20.357	19.4	104	-3	2	30	12	88	0
5	365	19.842	20.0	105	4	1	30	12	88	0
6	366	19.346	20.1	106	-5	1	30	12	88	0
7	367	18.837	20.0	107	4	1	30	12	88	0
8	368	18.328	20.0	108	5	1	30	12	68	0
9	369	17.803	19.9	109	2	1	30	12	68	0
10	370	17.282	19.9	110	6	1	30	12	68	0
11	371	16.778	19.9	111	20	1	30	12	68	0
12	372	16.258	19.9	112	-3	1	30	12	68	0
13	373	15.741	19.9	113	5	1	30	12	88	0
14	374	15.261	19.7	114	0	1	30	12	88	0
15	375	14.721	19.5	115	2	1	30	12	88	0
16	376	14.282	19.5	116	0	1	30	12	88	0
17	377	13.748	19.3	117	5	1	30	12	68	0
18	378	13.257	19.2	118	-2	1	30	12	68	0
19	379	12.745	19.1	119	2	1	30	12	68	0
20	380	12.249	19.0	120	0	1	30	12	68	0

FIELD DATA TABLE

SHOT NUMBER 20 SHOT POINT 4 TEAM 5
SHOT TIME: 312: 9: 4: 0.010

LOC	DIST(KM)	AZIM	UNIT	CHRON	CHAN	C1	C2	C3	TAPE	GRADE
1	398	48.539	81	10	2	30	12	48	0	0
2	399	49.062	82	-7	2	30	12	48	0	0
3	400	49.576	83	10	2	30	12	68	2	2
4	401	50.099	84	-10	2	30	12	88	0	0
5	402	50.584	85	-13	2	30	12	88	0	0
6	403	51.087	86	0	2	30	12	88	0	0
7	404	51.444	87	-9	2	30	12	88	0	0
8	405	52.071	88	15	2	30	12	88	0	0
9	406	52.577	89	0	2	30	12	88	0	0
10	407	53.094	90	4	2	30	12	68	2	2
11	408	53.567	91	5	2	30	12	68	0	0
12	409	54.049	92	-2	2	30	12	68	0	0
13	410	54.558	93	-3	2	30	12	68	0	0
14	411	55.072	94	13	2	30	12	68	0	0
15	413	56.082	95	-23	2	30	12	48	0	0
16	415	57.148	96	2	2	30	12	48	0	0
17	417	58.123	97	4	2	30	12	48	0	0
18	419	59.088	98	-19	2	30	12	48	0	0
19	14	84.766	99	12	2	30	12	48	1	1
20	12	108.760	100	7	2	30	12	48	0	0

FIELD DATA TABLE

SHOT NUMBER 20 SHOT POINT 4 TEAM 3
SHOT TIME: 312: 9: 4: 0.010

LOC	DIST(KM)	AZIM	UNIT	CHRON	CHAN	C1	C2	C3	TAPE	GRADE
1	341	20.171	41	16	1	30	12	48	0	0
2	342	20.632	42	1	1	30	12	48	0	0
3	343	21.166	43	2	1	30	12	48	3	3
4	344	21.641	44	11	2	30	12	48	0	0
5	345	22.182	45	0	2	30	12	48	3	3
6	346	22.677	46	12	2	30	12	48	0	0
7	347	23.191	47	20	2	30	12	48	0	0
8	348	23.701	48	-23	2	30	12	48	0	0
9	349	24.188	49	3	2	30	12	48	0	0
10	350	24.714	50	7	2	30	12	48	0	0
11	351	25.248	51	87	3	30	12	48	4	4
12	352	25.747	52	-5	2	30	12	48	0	0
13	353	26.269	53	3	2	30	12	48	0	0
14	354	26.773	54	4	2	30	12	48	0	0
15	355	27.255	55	-16	2	30	12	48	0	0
16	356	27.787	56	6	2	30	12	68	0	0
17	357	28.275	57	3	2	30	12	68	0	0
18	358	28.798	58	6	2	30	12	68	0	0
19	359	29.286	59	-3	1	30	12	68	0	0
20	360	29.771	60	-5	2	30	12	68	0	0

FIELD DATA TABLE

SHOT NUMBER 20 SHOT POINT 4 TEAM 6
SHOT TIME: 312: 9: 4: 0.010

LOC	DIST(KM)	AZIM	UNIT	CHRON	CHAN	C1	C2	C3	TAPE	GRADE
1	361	30.329	101	10	2	30	12	68	0	0
2	362	30.850	102	2	2	30	12	88	0	0
3	363	31.326	103	3	2	30	12	88	0	0
4	364	31.829	104	-3	2	30	12	88	0	0
5	365	32.243	105	4	2	30	12	88	0	0
6	366	32.706	106	-5	1	30	12	88	0	0
7	367	33.194	107	4	1	30	12	88	0	0
8	368	33.678	108	5	2	30	12	68	0	0
9	369	34.190	109	2	2	30	12	68	0	0
10	370	34.690	110	6	1	30	12	68	0	0
11	371	35.170	111	20	2	30	12	68	0	0
12	372	35.662	112	-3	2	30	12	68	0	0
13	373	36.161	113	5	2	30	12	88	0	0
14	374	36.632	114	0	2	30	12	88	0	0
15	375	37.161	115	2	2	30	12	88	0	0
16	376	37.585	116	0	1	30	12	88	0	0
17	377	38.109	117	5	1	30	12	68	0	0
18	378	38.583	118	-2	2	30	12	68	0	0
19	379	39.079	119	2	2	30	12	68	0	0
20	380	39.562	120	0	2	30	12	68	0	0

FIELD DATA TABLE

SHOT NUMBER 20 SHOT POINT 4 TEAM 4
SHOT TIME: 312: 9: 4: 0.010

LOC	DIST(KM)	AZIM	UNIT	CHRON	CHAN	C1	C2	C3	TAPE	GRADE
1	311	5.264	61	7	3	30	12	48	0	0
2	312	5.668	62	6	3	30	12	48	0	0
3	313	6.168	63	6	3	30	12	48	0	0
4	314	6.630	64	--	--	30	12	48	1	1
5	315	7.204	65	-22	1	30	12	48	2	2
6	316	7.794	66	4	1	30	12	48	0	0
7	317	8.232	67	0	1	30	12	48	0	0
8	318	8.713	68	-4	2	30	12	48	0	0
9	319	9.107	69	3	3	30	12	48	0	0
10	320	9.693	70	9	1	30	12	48	0	0
11	331	15.107	71	3	1	30	12	68	0	0
12	332	15.773	72	7	1	30	12	88	0	0
13	333	16.112	73	2	1	30	12	88	0	0
14	334	16.621	74	1	2	30	12	88	0	0
15	335	17.107	75	7	1	30	12	88	0	0
16	336	17.614	76	--	--	30	12	68	1	1
17	337	18.105	77	2	2	30	12	68	3	3
18	338	18.614	78	15	3	30	12	68	3	3
19	339	19.160	79	-77	--	30	12	68	3	3
20	340	19.659	80	3	3	30	12	68	3	3

FIELD DATA TABLE

SHOT NUMBER 21 SHOT POINT 15 TEAM 3
SHOT TIME: 312: 9: 6: 0.013

LOC	DIST(KM)	AZIM	UNIT	CHRON	CHAN	C1	C2	C3	TAPE	GRADE
1	341	16.953	41	16	2	30	12	48	0	0
2	342	16.487	42	1	1	30	12	48	0	0
3	343	15.947	43	2	2	30	12	48	0	3
4	344	15.468	44	11	2	30	12	48	0	0
5	345	14.925	45	0	0	30	12	48	0	3
6	346	14.428	46	12	2	30	12	48	0	0
7	347	13.915	47	20	2	30	12	48	0	0
8	348	13.407	48	-23	2	30	12	48	0	0
9	349	12.925	49	3	2	30	12	48	0	0
10	350	12.405	50	7	2	30	12	48	0	4
11	351	11.880	51	87	1	30	12	48	0	0
12	352	11.389	52	-5	1	30	12	48	0	0
13	353	10.880	53	3	1	30	12	48	0	0
14	354	10.390	54	4	1	30	12	48	0	0
15	355	9.926	55	-16	2	30	12	48	0	0
16	356	9.419	56	6	2	30	12	48	0	0
17	357	8.957	57	3	2	30	12	48	0	0
18	358	8.511	58	6	2	30	12	48	0	0
19	359	8.063	59	-3	1	30	12	48	0	0
20	360	7.554	60	-5	1	30	12	48	0	0

FIELD DATA TABLE

SHOT NUMBER 21 SHOT POINT 15 TEAM 1
SHOT TIME: 312: 9: 6: 0.013

LOC	DIST(KM)	AZIM	UNIT	CHRON	CHAN	C1	C2	C3	TAPE	GRADE
1	381	3.065	200.4	1	4	30	12	48	0	0
2	382	3.591	200.7	2	-10	30	12	48	0	1
3	383	4.090	200.8	3	6	30	12	48	0	0
4	384	4.629	200.8	4	-38	1	30	12	48	0
5	385	5.125	201.0	5	-8	1	30	12	48	0
6	386	5.619	201.0	6	3	1	30	12	48	0
7	387	6.144	201.1	7	-17	1	30	12	48	0
8	388	6.647	201.1	8	-23	1	30	12	48	0
9	389	7.275	201.1	9	20	2	30	12	48	0
10	390	7.826	199.7	10	31	1	30	12	48	0
11	391	8.372	198.4	11	-17	1	30	12	48	0
12	392	8.951	197.0	12	0	2	30	12	48	0
13	393	9.496	196.0	13	-6	2	30	12	48	0
14	394	10.023	195.4	14	1	2	30	12	48	1
15	395	10.616	194.6	15	0	2	30	12	48	0
16	396	11.041	196.0	16	9	30	12	48	0	3
17	397	11.625	194.6	17	5	2	30	12	48	0
18	5	57.058	38.7	18	-18	30	12	88	2	2
19	6	73.575	39.7	19	-17	30	12	88	2	2
20	7	105.343	39.2	20	-2	30	12	88	2	2

FIELD DATA TABLE

SHOT NUMBER 21 SHOT POINT 15 TEAM 4
SHOT TIME: 312: 9: 6: 0.013

LOC	DIST(KM)	AZIM	UNIT	CHRON	CHAN	C1	C2	C3	TAPE	GRADE
1	311	31.856	61	7	2	30	12	48	0	0
2	312	31.438	62	6	2	30	12	48	0	0
3	313	30.943	63	6	2	30	12	48	0	1
4	314	30.499	64	--	--	30	12	48	2	2
5	315	29.913	65	-22	4	2	30	12	48	0
6	316	29.339	66	4	0	1	30	12	48	0
7	317	28.859	67	0	2	30	12	48	0	0
8	318	28.396	68	-4	2	30	12	48	0	0
9	319	28.012	69	3	2	30	12	48	0	0
10	320	27.449	70	9	2	30	12	48	0	0
11	321	22.037	71	3	2	30	12	88	0	0
12	322	21.393	72	2	2	30	12	88	0	0
13	323	21.036	73	1	2	30	12	88	0	0
14	324	20.529	74	1	2	30	12	88	0	0
15	325	20.043	75	7	2	30	12	88	0	0
16	326	19.539	76	--	--	30	12	68	1	3
17	327	19.034	77	2	2	30	12	68	0	0
18	328	18.524	78	15	2	30	12	68	0	3
19	329	17.989	79	-78	3	30	12	68	0	3
20	340	17.481	80	39.3	3	30	12	68	0	3

FIELD DATA TABLE

SHOT NUMBER 21 SHOT POINT 15 TEAM 2
SHOT TIME: 312: 9: 6: 0.013

LOC	DIST(KM)	AZIM	UNIT	CHRON	CHAN	C1	C2	C3	TAPE	GRADE
1	310	32.432	36.8	21	1	2	30	12	88	0
2	309	32.934	36.1	22	6	2	30	12	88	0
3	308	33.430	35.4	23	5	2	30	12	88	0
4	307	33.958	36.4	24	-6	2	30	12	48	0
5	306	34.487	36.9	25	-11	2	30	12	48	0
6	305	34.941	36.6	26	6	2	30	12	48	0
7	304	35.445	37.0	27	0	2	30	12	48	0
8	303	35.949	36.9	28	-29	2	30	12	48	0
9	142	36.962	36.8	29	6	2	30	12	48	0
10	302	36.476	36.9	30	3	2	30	12	48	0
11	321	26.937	38.1	31	5	2	30	12	48	0
12	322	26.507	38.2	32	9	2	30	12	48	0
13	323	26.015	38.8	33	24	2	30	12	48	0
14	324	25.515	39.1	34	7	1	30	12	48	0
15	325	25.035	39.2	35	-23	1	30	12	48	0
16	326	24.546	39.5	36	0	1	30	12	48	0
17	327	24.006	39.6	37	5	30	12	48	2	2
18	328	23.566	39.0	38	4	2	30	12	48	0
19	329	22.989	38.8	39	2	2	30	12	48	0
20	330	22.555	38.9	40	4	2	30	12	88	0

FIELD DATA TABLE

SHOT NUMBER 22 SHOT POINT 12 TEAM 1
 SHOT TIME: 317: 6: 0: 2.930

LOC	DIST(KM)	AZIM	UNIT	CHRON	CHAN	C1	C2	C3	TAPE	GRADE
1	142	108.898	225.9	1	20	30	12	88	3	0
2	502	108.203	226.0	2	17	2	30	12	88	0
3	503	107.460	226.0	3	15	2	30	12	88	0
4	504	106.934	226.0	4	-16	2	30	12	88	0
5	505	106.261	225.9	5	21	2	30	12	68	0
6	506	105.703	225.8	6	6	2	30	12	68	0
7	507	105.191	225.8	7	-7	2	30	12	68	0
8	508	104.494	226.0	8	1	2	30	12	68	0
9	509	103.937	226.0	9	84	2	30	12	48	0
10	510	103.365	226.0	10	115	2	30	12	48	0
11	511	102.899	226.1	11	13	2	30	12	48	0
12	512	102.092	226.1	12	13	2	30	12	48	2
13	513	101.563	226.1	13	17	2	30	12	48	0
14	514	100.941	226.2	14	11	2	30	12	48	0
15	515	100.238	226.2	15	13	3	30	12	48	4
16	516	99.726	226.2	16	16	2	30	12	48	1
17	517	99.198	226.4	17	17	2	30	12	48	0
18	518	98.632	226.4	18	-27	2	30	12	48	0
19	519	97.953	226.4	19	99	2	30	12	48	0
20	520	97.496	226.3	20	39	2	30	12	48	0

LOC	DIST(KM)	AZIM	UNIT	CHRON	CHAN	C1	C2	C3	TAPE	GRADE
1	398	12.133	194.6	81	10	1	30	12	48	0
2	399	12.664	194.5	82	-7	1	30	12	48	0
3	400	13.185	194.7	83	10	30	12	68	2	0
4	401	13.626	196.3	84	-10	2	30	12	88	0
5	402	14.010	198.2	85	-13	2	30	12	88	0
6	403	14.460	199.3	86	0	2	30	12	88	0
7	404	14.815	199.3	87	-9	1	30	12	88	0
8	405	15.377	200.9	88	15	2	30	12	88	0
9	406	15.822	202.3	89	0	2	30	12	88	0
10	407	16.293	203.4	90	4	4	30	12	68	2
11	408	16.718	204.6	91	5	2	30	12	68	0
12	409	17.142	206.2	92	-2	2	30	12	68	0
13	410	17.642	206.5	93	-3	2	30	12	68	0
14	411	18.198	206.6	94	13	2	30	12	68	0
15	413	19.135	207.6	95	-23	2	30	12	48	0
16	415	20.143	209.6	96	2	2	30	12	48	0
17	417	21.062	212.1	97	4	2	30	12	48	0
18	419	22.054	210.9	98	-19	2	30	12	48	0
19	14	47.668	218.2	99	12	30	12	48	1	1
20	12	145.556	43.1	100	.7	30	12	48	3	3

SHOT NUMBER 21 SHOT POINT 15 TEAM 5
 SHOT TIME: 312: 9: 6: 0.013

FIELD DATA TABLE

SHOT NUMBER 22 SHOT POINT 12 TEAM 2
 SHOT TIME: 317: 6: 0: 2.930

LOC	DIST(KM)	AZIM	UNIT	CHRON	CHAN	C1	C2	C3	TAPE	GRADE
1	521	96.857	226.1	21	-5	2	30	12	48	0
2	522	96.191	226.3	22	11	2	30	12	48	0
3	523	95.742	226.4	23	21	1	30	12	48	0
4	524	95.032	226.4	24	-2	2	30	12	48	0
5	525	94.434	226.8	25	10	2	30	12	48	2
6	526	93.921	227.2	26	8	2	30	12	48	0
7	527	93.354	227.2	27	7	2	30	12	48	0
8	528	92.886	227.3	28	-27	1	30	12	48	0
9	529	92.195	227.4	29	14	1	30	12	48	0
10	530	91.710	227.1	30	6	2	30	12	48	0
11	531	90.999	226.9	31	7	2	30	12	48	0
12	532	90.305	226.6	32	29	2	30	12	48	1
13	533	89.787	226.6	33	4	2	30	12	48	0
14	534	89.099	226.6	34	13	2	30	12	48	0
15	535	88.717	226.6	35	-33	2	30	12	48	0
16	536	88.487	226.2	36	3	2	30	12	48	0
17	537	87.807	226.1	37	6	2	30	12	48	0
18	538	87.377	226.2	38	6	2	30	12	48	0
19	539	86.433	226.4	39	--	2	30	12	48	1
20	540	85.975	226.5	40	6	2	30	12	48	1

FIELD DATA TABLE

SHOT NUMBER 21 SHOT POINT 15 TEAM 6
 SHOT TIME: 312: 9: 6: 0.013

LOC	DIST(KM)	AZIM	UNIT	CHRON	CHAN	C1	C2	C3	TAPE	GRADE
1	361	7.029	22.8	101	10	1	30	12	68	0
2	362	6.588	20.1	102	2	1	30	12	88	0
3	363	6.085	20.0	103	3	1	30	12	88	0
4	364	5.554	19.9	104	-3	1	30	12	88	0
5	365	5.044	22.4	105	4	1	30	12	88	0
6	366	4.550	22.9	106	-5	1	30	12	88	0
7	367	4.040	23.0	107	4	1	30	12	88	0
8	368	3.532	23.4	108	5	3	30	12	68	0
9	369	3.006	23.2	109	2	3	30	12	68	0
10	370	2.485	23.6	110	7	3	30	12	68	0
11	371	1.982	24.6	111	20	3	30	12	68	0
12	372	1.466	26.8	112	3	3	30	12	68	0
13	373	0.952	29.6	113	5	3	30	12	88	0
14	374	0.474	34.4	114	0	3	30	12	88	0
15	375	0.113	156.3	115	2	3	30	12	88	0
16	376	0.525	192.7	116	0	3	30	12	88	0
17	377	1.055	198.6	117	5	3	30	12	68	0
18	378	1.546	199.3	118	-2	3	30	12	68	0
19	379	2.058	199.9	119	2	3	30	12	68	0
20	380	2.555	200.3	120	0	3	30	12	68	0

FIELD DATA TABLE

SHOT NUMBER 22 SHOT POINT 12 TEAM 5
 SHOT TIME: 317: 6: 0: 2.930

LOC	DIST(KM)	AZIM	UNIT	CHRON	CHAN	C1	C2	C3	TAPE	GRADE
1	591	54.645	227.6	81	13	2	30	12	88	0
2	592	54.059	227.7	82	-7	2	30	12	88	0
3	593	53.474	227.9	83	25	2	30	12	88	0
4	594	52.951	228.0	84	-2	2	30	12	68	0
5	595	52.276	228.0	85	17	2	30	12	68	0
6	596	51.663	227.9	86	-4	2	30	12	68	0
7	597	51.063	227.8	87	-8	1	30	12	68	0
8	598	50.434	227.7	88	21	2	30	12	68	0
9	599	49.899	228.2	89	-4	2	30	12	48	3
10	600	49.364	228.9	90	16	2	30	12	48	0
11	601	48.848	229.6	91	8	2	30	12	48	0
12	602	48.319	230.3	92	0	2	30	12	48	0
13	603	47.773	230.8	93	25	2	30	12	48	0
14	604	47.194	231.0	94	24	2	30	12	48	0
15	605	46.613	231.2	95	9	2	30	12	48	0
16	1	159.207	221.6	96	-8	2	30	12	48	0
17	3	124.181	224.4	97	-11	2	30	12	48	0
18	2	140.492	224.6	98	23	1	30	12	48	0
19	14	193.091	222.5	99	23	1	30	12	48	0
20	12	0.000	180.0	100	10	2	30	12	48	3

FIELD DATA TABLE

SHOT NUMBER 22 SHOT POINT 12 TEAM 3
 SHOT TIME: 317: 6: 0: 2.930

LOC	DIST(KM)	AZIM	UNIT	CHRON	CHAN	C1	C2	C3	TAPE	GRADE
1	571	66.649	226.8	41	29	2	30	12	48	0
2	572	66.009	225.9	42	11	2	30	12	48	0
3	573	65.353	225.9	43	10	2	30	12	48	0
4	574	64.739	225.9	44	33	2	30	12	48	0
5	575	64.161	226.1	45	-2	2	30	12	48	0
6	576	63.592	226.3	46	25	2	30	12	48	0
7	577	63.033	226.9	47	33	2	30	12	48	0
8	578	62.509	227.5	48	36	2	30	12	48	0
9	579	61.898	227.4	49	15	2	30	12	48	0
10	580	61.271	227.4	50	-18	2	30	12	48	0
11	581	60.647	227.2	51	29	2	30	12	48	0
12	582	60.069	227.1	52	15	2	30	12	48	0
13	583	59.441	227.1	53	11	2	30	12	68	0
14	584	58.854	227.2	54	11	2	30	12	68	0
15	585	58.214	227.1	55	-8	2	30	12	68	0
16	586	57.623	227.1	56	13	2	30	12	68	0
17	587	57.083	227.4	57	32	2	30	12	68	0
18	588	56.451	226.9	58	14	2	30	12	68	0
19	589	55.858	227.3	59	1	2	30	12	88	0
20	590	55.248	227.5	60	-5	2	30	12	88	0

FIELD DATA TABLE

SHOT NUMBER 22 SHOT POINT 12 TEAM 6
 SHOT TIME: 317: 6: 0: 2.930

LOC	DIST(KM)	AZIM	UNIT	CHRON	CHAN	C1	C2	C3	TAPE	GRADE
1	541	85.283	226.5	101	19	2	30	12	68	0
2	542	84.775	226.1	102	7	2	30	12	68	0
3	543	83.474	226.5	103	2	2	30	12	48	0
4	544	82.818	226.5	104	0	1	30	12	48	0
5	545	82.263	226.3	105	21	2	30	12	48	0
6	546	81.646	226.3	106	0	2	30	12	48	0
7	547	80.999	226.2	107	34	2	30	12	48	0
8	548	80.358	226.1	108	15	2	30	12	48	0
9	549	79.905	226.1	109	6	1	30	12	48	0
10	550	79.245	226.1	110	14	2	30	12	48	0
11	606	46.042	231.4	111	69	2	30	12	48	0
12	607	45.460	231.7	112	13	2	30	12	48	0
13	608	44.868	231.9	113	8	2	30	12	68	0
14	609	44.312	232.2	114	6	2	30	12	68	0
15	610	43.744	232.5	115	10	2	30	12	68	0
16	611	43.179	232.7	116	13	2	30	12	68	0
17	612	42.586	233.0	117	22	2	30	12	68	0
18	613	42.028	233.3	118	17	1	30	12	88	0
19	614	41.466	233.7	119	7	1	30	12	88	0
20	615	41.058	233.8	120	4	2	30	12	88	0

FIELD DATA TABLE

SHOT NUMBER 22 SHOT POINT 12 TEAM 4
 SHOT TIME: 317: 6: 0: 2.930

LOC	DIST(KM)	AZIM	UNIT	CHRON	CHAN	C1	C2	C3	TAPE	GRADE
1	551	78.618	226.4	61	14	2	30	12	48	0
2	552	78.037	226.4	62	4	2	30	12	48	0
3	553	77.270	226.3	63	10	2	30	12	48	0
4	554	76.751	226.3	64	12	1	30	12	48	0
5	555	76.095	226.4	65	-11	1	30	12	68	0
6	556	75.577	226.5	66	13	1	30	12	68	0
7	557	74.990	226.7	67	31	1	30	12	68	3
8	558	74.359	226.8	68	1	1	30	12	68	0
9	559	73.854	226.9	69	6	1	30	12	68	0
10	560	73.406	227.2	70	31	1	30	12	68	0
11	561	72.752	227.3	71	39	2	30	12	88	0
12	562	72.208	227.2	72	18	2	30	12	88	0
13	563	71.612	227.1	73	-3	2	30	12	88	0
14	564	70.918	226.9	74	3	2	30	12	88	0
15	565	70.283	226.9	75	15	1	30	12	68	1
16	566	69.679	226.9	76	19	1	30	12	68	0
17	567	69.073	226.9	77	14	2	30	12	68	0
18	568	68.497	227.0	78	10	1	30	12	68	0
19	569	67.857	226.9	79	-7	1	30	12	68	0
20	570	67.262	226.9	80	7	1	30	12	48	0

FIELD DATA TABLE

SHOT NUMBER 23 SHOT POINT 14 TEAM 3
SHOT TIME: 317: 6: 2: 0.011

LOC	DIST(KM)	AZIM	UNIT	CHRON	CHAN	C1	C2	C3	TAPE	GRADE
1	571	126.721	39.5	41	29	2	30	12 48	0	0
2	572	127.259	40.0	42	11	1	30	12 48	0	0
3	573	127.913	40.0	43	10	1	30	12 48	0	0
4	574	128.525	40.0	44	33	2	30	12 48	0	0
5	575	129.117	40.0	45	-2	1	30	12 48	0	0
6	576	129.708	39.9	46	29	1	30	12 48	0	0
7	577	130.324	39.6	47	33	1	30	12 48	0	0
8	578	130.935	39.3	48	36	2	30	12 48	0	0
9	579	131.525	39.4	49	15	1	30	12 48	0	0
10	580	132.141	39.5	50	-18	1	30	12 48	0	0
11	581	132.732	39.6	51	29	1	30	12 48	0	0
12	582	133.297	39.7	52	15	1	30	12 48	0	0
13	583	133.919	39.7	53	11	1	30	12 68	0	0
14	584	134.513	39.7	54	11	2	30	12 68	0	0
15	585	135.139	39.8	55	-8	1	30	12 68	0	0
16	586	135.733	39.8	56	13	1	30	12 68	0	0
17	587	136.305	39.7	57	32	1	30	12 68	0	0
18	588	136.873	39.9	58	14	1	30	12 68	0	0
19	589	137.506	39.8	59	1	1	30	12 88	0	0
20	590	138.132	39.8	60	-5	1	30	12 88	0	0

FIELD DATA TABLE

SHOT NUMBER 23 SHOT POINT 14 TEAM 1
SHOT TIME: 317: 6: 2: 0.011

LOC	DIST(KM)	AZIM	UNIT	CHRON	CHAN	C1	C2	C3	TAPE	GRADE
1	142	84.624	37.4	1	20	3	30	12 88	0	3
2	502	85.343	37.3	2	17	1	30	12 88	0	0
3	503	86.068	37.4	3	15	1	30	12 88	0	0
4	504	86.589	37.5	4	-16	1	30	12 68	0	0
5	505	87.245	37.6	5	21	1	30	12 68	0	0
6	506	87.774	37.8	6	6	1	30	12 68	0	0
7	507	88.284	37.8	7	-7	1	30	12 68	0	0
8	508	89.009	37.7	8	1	2	30	12 68	0	0
9	509	89.574	37.7	9	84	2	30	12 48	0	0
10	510	90.127	37.8	10	115	2	30	12 48	0	0
11	511	90.616	37.7	11	13	1	30	12 48	0	2
12	512	91.408	37.8	12	13	2	30	12 48	0	0
13	513	91.942	37.8	13	17	2	30	12 48	0	0
14	514	92.582	37.7	14	11	2	30	12 48	0	4
15	515	93.273	37.8	15	13	30	12 48	0	1	0
16	516	93.792	37.8	16	16	30	12 48	0	0	0
17	517	94.360	37.7	17	17	2	30	12 48	0	0
18	518	94.922	37.7	18	-27	2	30	12 48	0	0
19	519	95.580	37.8	19	100	2	30	12 48	0	0
20	520	96.010	38.0	20	39	2	30	12 48	0	0

FIELD DATA TABLE

SHOT NUMBER 23 SHOT POINT 14 TEAM 4
SHOT TIME: 317: 6: 2: 0.011

LOC	DIST(KM)	AZIM	UNIT	CHRON	CHAN	C1	C2	C3	TAPE	GRADE
1	551	114.782	39.1	61	14	1	30	12 48	0	0
2	552	115.350	39.1	62	4	1	30	12 48	0	0
3	553	116.098	39.2	63	10	1	30	12 48	0	0
4	554	116.619	39.2	64	12	1	30	12 48	0	0
5	555	117.279	39.2	65	-11	1	30	12 68	0	0
6	556	117.816	39.2	66	13	1	30	12 68	0	3
7	557	118.419	39.1	67	31	1	30	12 68	0	0
8	558	119.061	39.1	68	1	1	30	12 68	0	0
9	559	119.591	39.0	69	6	1	30	12 68	0	0
10	560	120.085	38.9	70	31	089	30	12 88	0	0
11	561	120.737	38.9	71	39	2	30	12 88	0	0
12	562	121.271	38.9	72	18	1	30	12 88	0	0
13	563	121.835	39.1	73	-3	2	30	12 88	0	0
14	564	122.502	39.2	74	3	1	30	12 88	0	0
15	565	123.129	39.2	75	15	1	30	12 68	1	0
16	566	123.731	39.3	76	19	1	30	12 68	0	0
17	567	124.332	39.3	77	14	1	30	12 68	0	0
18	568	124.921	39.3	78	10	1	30	12 68	3	0
19	569	125.536	39.4	79	-7	1	30	12 68	0	0
20	570	126.122	39.4	80	7	1	30	12 48	0	0

FIELD DATA TABLE

SHOT NUMBER 23 SHOT POINT 14 TEAM 2
SHOT TIME: 317: 6: 2: 0.011

LOC	DIST(KM)	AZIM	UNIT	CHRON	CHAN	C1	C2	C3	TAPE	GRADE
1	521	96.617	38.1	21	-5	12	30	12 48	0	0
2	522	97.311	38.0	22	11	2	30	12 48	0	0
3	523	97.793	37.9	23	21	1	30	12 48	0	0
4	524	98.493	38.0	24	-2	1	30	12 48	0	0
5	525	99.167	37.7	25	10	1	30	12 48	0	0
6	526	99.768	37.4	26	8	1	30	12 48	0	0
7	527	100.346	37.3	27	7	2	30	12 48	0	0
8	528	100.826	37.3	28	-27	1	30	12 48	0	0
9	529	101.525	37.3	29	15	2	30	12 48	0	0
10	530	101.932	37.6	30	6	2	30	12 48	0	0
11	531	102.600	37.8	31	7	2	30	12 48	0	1
12	532	103.208	38.2	32	29	4	30	12 48	0	0
13	533	103.733	38.2	33	4	2	30	12 48	0	0
14	534	104.402	38.3	34	13	1	30	12 48	0	0
15	535	104.779	38.3	35	-33	1	30	12 48	0	0
16	536	104.947	38.5	36	3	1	30	12 48	0	0
17	537	105.593	38.8	37	6	1	30	12 48	0	0
18	538	106.044	38.7	38	6	2	30	12 48	0	0
19	539	107.015	38.6	39	--	1	30	12 48	1	0
20	540	107.486	38.6	40	6	6	30	12 48	2	0

FIELD DATA TABLE

SHOT NUMBER 24 SHOT POINT 5 TEAM 1
 SHOT TIME: 317: 6: 4: 0.154

LOC	DIST(KM)	AZIM	UNIT	CHRON	CHAN	C1	C2	C3	TAPE	GRADE
1	20.158	222.6	1	20	1	30	12	88	3	0
2	19.453	223.2	2	17	1	30	12	88	0	0
3	18.715	222.8	3	15	1	30	12	88	0	0
4	18.189	222.7	4	-16	1	30	12	68	0	0
5	17.520	222.4	5	21	1	30	12	68	0	0
6	16.976	221.6	6	6	1	30	12	68	0	0
7	16.464	221.5	7	-7	1	30	12	68	0	0
8	15.752	222.3	8	1	1	30	12	68	0	0
9	15.190	222.6	9	84	1	30	12	48	0	0
10	14.626	222.0	10	115	1	30	12	48	0	0
11	14.149	222.7	11	13	1	30	12	48	0	0
12	13.347	222.3	12	13	1	30	12	48	0	0
13	12.814	222.5	13	17	1	30	12	48	0	0
14	12.183	223.1	14	11	1	30	12	48	0	0
15	11.484	222.8	15	13	1	30	12	48	4	4
16	10.968	223.0	16	16	1	30	12	48	1	1
17	10.429	224.7	17	17	1	30	12	48	0	0
18	9.863	224.8	18	-27	1	30	12	48	0	0
19	9.187	224.0	19	100	1	30	12	48	0	0
20	8.738	222.7	20	39	1	30	12	48	0	0

FIELD DATA TABLE

SHOT NUMBER 23 SHOT POINT 14 TEAM 5
 SHOT TIME: 317: 6: 2: 0.011

LOC	DIST(KM)	AZIM	UNIT	CHRON	CHAN	C1	C2	C3	TAPE	GRADE
1	138.746	39.7	81	13	1	30	12	88	0	0
2	139.341	39.7	82	-7	1	30	12	88	0	0
3	139.937	39.7	83	25	1	30	12	88	0	0
4	140.477	39.7	84	-2	1	30	12	68	0	0
5	141.138	39.7	85	17	1	30	12	68	0	0
6	141.737	39.8	86	-4	1	30	12	68	0	0
7	142.323	39.8	87	-8	1	30	12	68	0	0
8	142.938	39.8	88	21	1	30	12	68	0	0
9	143.518	39.8	89	-4	1	30	12	48	3	3
10	144.132	39.6	90	16	1	30	12	48	0	0
11	144.736	39.4	91	8	1	30	12	48	0	0
12	145.359	39.2	92	25	2	30	12	48	0	0
13	145.969	39.1	93	24	2	30	12	48	0	0
14	146.574	39.0	94	9	2	30	12	48	0	0
15	147.174	39.0	95	-8	1	30	12	48	0	0
16	147.774	38.4	96	4	1	30	12	48	0	0
17	148.374	38.4	97	-11	1	30	12	48	3	3
18	148.974	36.2	98	23	2	30	12	48	3	3
19	149.574	180.0	99	10	2	30	12	48	0	0
20	150.174	41.7	100	10	2	30	12	48	0	0

FIELD DATA TABLE

SHOT NUMBER 24 SHOT POINT 5 TEAM 2
 SHOT TIME: 317: 6: 4: 0.154

LOC	DIST(KM)	AZIM	UNIT	CHRON	CHAN	C1	C2	C3	TAPE	GRADE
1	8.115	221.0	21	-5	3	30	12	48	0	0
2	7.432	222.6	22	11	1	30	12	48	0	0
3	6.972	224.6	23	21	1	30	12	48	0	0
4	6.263	224.3	24	-2	1	30	12	48	0	0
5	5.673	230.0	25	10	3	30	12	48	2	2
6	5.240	237.2	26	8	3	30	12	48	0	0
7	4.708	239.8	27	7	3	30	12	48	0	0
8	4.281	242.6	28	-27	3	30	12	48	0	0
9	3.657	247.2	29	15	3	30	12	48	0	0
10	3.052	242.2	30	6	3	30	12	48	0	0
11	2.306	241.4	31	7	3	30	12	48	0	0
12	1.533	227.1	32	29	3	30	12	48	1	1
13	1.021	232.3	33	4	3	30	12	48	0	0
14	0.327	227.3	34	13	3	30	12	48	0	0
15	0.055	47.8	35	-33	3	30	12	48	0	0
16	0.560	105.4	36	3	3	30	12	48	0	0
17	1.214	83.3	37	6	3	30	12	48	0	0
18	1.493	66.8	38	6	3	30	12	48	0	0
19	2.352	52.0	39	-	6	30	12	48	1	1
20	2.799	48.2	40	-	6	30	12	48	2	2

FIELD DATA TABLE

SHOT NUMBER 23 SHOT POINT 14 TEAM 6
 SHOT TIME: 317: 6: 2: 0.011

LOC	DIST(KM)	AZIM	UNIT	CHRON	CHAN	C1	C2	C3	TAPE	GRADE
1	108.180	38.6	101	19	1	30	12	68	0	0
2	108.601	39.0	102	7	2	30	12	68	0	0
3	109.976	38.7	103	2	1	30	12	48	0	0
4	110.626	38.7	104	0	1	30	12	48	0	0
5	111.145	38.9	105	21	1	30	12	48	0	0
6	111.753	39.0	106	0	1	30	12	48	0	0
7	112.377	39.1	107	34	1	30	12	48	0	0
8	113.005	39.2	108	15	1	30	12	48	0	0
9	113.449	39.2	109	6	1	30	12	48	0	0
10	114.106	39.3	110	14	1	30	12	48	0	0
11	147.777	39.0	111	69	1	30	12	48	0	0
12	148.388	38.9	112	13	2	30	12	48	0	0
13	149.006	38.9	113	8	2	30	12	68	0	0
14	149.595	38.9	114	6	1	30	12	68	0	0
15	150.197	38.8	115	10	1	30	12	68	0	0
16	150.788	38.8	116	13	2	30	12	68	0	0
17	151.414	38.8	117	22	1	30	12	68	0	0
18	152.006	38.8	118	17	1	30	12	88	0	0
19	152.618	38.7	119	7	1	30	12	88	0	0
20	153.043	38.7	120	4	2	30	12	88	0	0

FIELD DATA TABLE

SHOT NUMBER 24 SHOT POINT 5 TEAM 5
SHOT TIME: 317: 6: 4: 0.154

LOC	DIST(KM)	AZIM	UNIT	CHRON	CHAN	C1	C2	C3	TAPE	GRADE
1	591	34.151	81	13	2	30	12	88	0	0
2	592	34.742	82	-7	2	30	12	88	0	0
3	593	35.333	83	25	2	30	12	88	0	0
4	594	35.865	84	-2	2	30	12	68	0	0
5	595	36.535	85	17	2	30	12	68	0	0
6	596	37.143	86	-4	2	30	12	68	0	0
7	597	37.738	87	-8	2	30	12	68	0	0
8	598	38.363	88	21	2	30	12	68	0	0
9	599	38.918	89	-4	2	30	12	48	0	0
10	600	39.499	90	16	2	30	12	48	3	3
11	601	40.074	91	8	2	30	12	48	0	0
12	602	40.676	92	0	2	30	12	48	0	0
13	603	41.275	93	25	2	30	12	48	0	0
14	604	41.877	94	24	2	30	12	48	0	0
15	605	42.476	95	9	2	30	12	48	0	0
16	1	71.186	96	-8	2	30	12	48	0	0
17	2	35.635	97	4	2	30	12	48	0	0
18	3	51.859	98	-11	2	30	12	48	0	0
19	14	104.725	99	23	1	30	12	48	0	0
20	12	88.772	100	10	2	30	12	48	3	3

FIELD DATA TABLE

SHOT NUMBER 24 SHOT POINT 5 TEAM 3
SHOT TIME: 317: 6: 4: 0.154

LOC	DIST(KM)	AZIM	UNIT	CHRON	CHAN	C1	C2	C3	TAPE	GRADE
1	571	22.125	41	29	2	30	12	48	0	0
2	572	22.779	42	11	2	30	12	48	0	0
3	573	23.434	43	10	2	30	12	48	0	0
4	574	24.047	44	33	2	30	12	48	0	0
5	575	24.618	45	-2	2	30	12	48	0	0
6	576	25.182	46	29	1	30	12	48	0	0
7	577	25.742	47	33	2	30	12	48	0	0
8	578	26.294	48	36	1	30	12	48	0	0
9	579	26.897	49	15	1	30	12	48	0	0
10	580	27.521	50	-18	2	30	12	48	0	0
11	581	28.136	51	29	1	30	12	48	0	0
12	582	28.711	52	15	1	30	12	48	0	0
13	583	29.338	53	11	2	30	12	68	0	0
14	584	29.928	54	11	2	30	12	68	0	0
15	585	30.565	55	-8	2	30	12	68	0	0
16	586	31.158	56	13	2	30	12	68	0	0
17	587	31.708	57	32	2	30	12	68	0	0
18	588	32.324	58	14	2	30	12	68	0	0
19	589	32.927	59	1	2	30	12	88	0	0
20	590	33.543	60	-5	2	30	12	88	0	0

FIELD DATA TABLE

SHOT NUMBER 24 SHOT POINT 5 TEAM 6
SHOT TIME: 317: 6: 4: 0.154

LOC	DIST(KM)	AZIM	UNIT	CHRON	CHAN	C1	C2	C3	TAPE	GRADE
1	541	3.489	101	19	3	30	12	68	0	0
2	542	4.070	102	7	1	30	12	68	0	0
3	543	5.299	103	2	3	30	12	48	0	0
4	544	5.955	104	0	3	30	12	48	0	0
5	545	6.517	105	21	1	30	12	48	0	0
6	546	7.135	106	0	1	30	12	48	0	0
7	547	7.792	107	34	1	30	12	48	0	0
8	548	8.437	108	15	1	30	12	48	0	0
9	549	8.894	109	6	1	30	12	48	0	0
10	550	9.552	110	14	3	30	12	48	0	0
11	606	43.075	111	69	2	30	12	48	0	0
12	607	43.684	112	13	2	30	12	48	0	0
13	608	44.301	113	9	2	30	12	68	0	0
14	609	44.887	114	6	2	30	12	68	0	0
15	610	45.487	115	10	2	30	12	68	0	0
16	611	46.077	116	13	2	30	12	68	0	0
17	612	46.701	117	22	2	30	12	68	0	0
18	613	47.292	118	17	2	30	12	68	0	0
19	614	47.901	119	7	2	30	12	88	0	0
20	615	48.327	120	4	2	30	12	88	0	0

FIELD DATA TABLE

SHOT NUMBER 24 SHOT POINT 5 TEAM 4
SHOT TIME: 317: 6: 4: 0.154

LOC	DIST(KM)	AZIM	UNIT	CHRON	CHAN	C1	C2	C3	TAPE	GRADE
1	551	10.155	61	14	1	30	12	48	0	0
2	552	10.738	62	4	1	30	12	48	0	0
3	553	11.310	63	10	1	30	12	48	0	0
4	554	12.026	64	12	1	30	12	48	0	0
5	555	12.680	65	-11	1	30	12	68	0	0
6	556	13.195	66	13	1	30	12	68	0	0
7	557	13.782	67	31	1	30	12	68	2	2
8	558	14.416	68	1	1	30	12	68	0	0
9	559	14.928	69	6	2	30	12	68	0	0
10	560	15.396	70	31	1	30	12	88	0	0
11	561	16.050	71	39	2	30	12	88	2	2
12	562	16.521	72	18	2	30	12	88	0	0
13	563	17.174	73	-3	2	30	12	88	0	0
14	564	17.862	74	3	2	30	12	88	0	0
15	565	18.495	75	15	1	30	12	68	1	1
16	566	19.099	76	19	1	30	12	68	0	0
17	567	19.705	77	14	1	30	12	68	0	0
18	568	20.285	78	10	1	30	12	68	3	3
19	569	20.920	79	-7	1	30	12	68	0	0
20	570	21.514	80	7	2	30	12	48	0	0

FIELD DATA TABLE

SHOT NUMBER 25 SHOT POINT 11 TEAM 1
 SHOT TIME: 317: 6: 6: 0.010

LOC	DIST(KM)	AZIM	UNIT	CHRON	CHAN	C1	C2	C3	TAPE	GRADE
1	142	116.055	144.5	1	20	30	12	88	3	0
2	502	115.713	144.2	2	17	2	30	12	88	0
3	503	115.682	143.8	3	15	2	30	12	88	0
4	504	115.606	143.6	4	-16	2	30	12	68	0
5	505	115.563	143.3	5	21	2	30	12	68	0
6	506	115.698	143.0	6	6	2	30	12	68	0
7	507	115.612	142.7	7	-7	2	30	12	68	0
8	508	115.257	142.4	8	1	2	30	12	68	0
9	509	115.092	142.1	9	84	2	30	12	48	0
10	510	115.131	141.8	10	116	2	30	12	48	0
11	511	114.867	141.6	11	13	2	30	12	48	0
12	512	114.845	141.2	12	13	2	30	12	48	2
13	513	114.715	140.9	13	17	2	30	12	48	0
14	514	114.489	140.6	14	11	2	30	12	48	0
15	515	114.458	140.3	15	13	30	12	48	4	0
16	516	114.335	140.0	16	16	30	12	48	1	0
17	517	113.960	139.8	17	17	2	30	12	48	0
18	518	113.905	139.5	18	-27	2	30	12	48	0
19	519	113.972	139.2	19	100	2	30	12	48	0
20	520	114.112	138.9	20	39	2	30	12	48	0

FIELD DATA TABLE

SHOT NUMBER 25 SHOT POINT 11 TEAM 3
 SHOT TIME: 317: 6: 6: 0.010

LOC	DIST(KM)	AZIM	UNIT	CHRON	CHAN	C1	C2	C3	TAPE	GRADE
1	571	115.739	123.5	41	29	2	30	12	48	0
2	572	116.834	123.3	42	11	2	30	12	48	0
3	573	116.964	123.0	43	10	2	30	12	48	0
4	574	117.080	122.7	44	33	2	30	12	48	0
5	575	117.034	122.4	45	-2	2	30	12	48	0
6	576	116.911	122.1	46	29	2	30	12	48	0
7	577	116.492	121.8	47	33	2	30	12	48	0
8	578	115.893	121.4	48	36	2	30	12	48	0
9	579	116.171	121.2	49	15	2	30	12	48	0
10	580	116.386	120.9	50	-18	2	30	12	48	0
11	581	116.788	120.6	51	29	2	30	12	48	0
12	582	117.024	120.3	52	15	2	30	12	48	0
13	583	117.203	120.0	53	11	2	30	12	48	0
14	584	117.282	119.8	54	11	2	30	12	68	0
15	585	117.548	119.5	55	-8	2	30	12	68	0
16	586	117.664	119.2	56	13	2	30	12	68	0
17	587	117.527	118.9	57	32	2	30	12	68	0
18	588	118.222	118.7	58	14	2	30	12	68	0
19	589	118.024	118.3	59	1	2	30	12	88	0
20	590	118.057	118.0	60	-5	2	30	12	88	0

FIELD DATA TABLE

SHOT NUMBER 25 SHOT POINT 11 TEAM 2
 SHOT TIME: 317: 6: 6: 0.010

LOC	DIST(KM)	AZIM	UNIT	CHRON	CHAN	C1	C2	C3	TAPE	GRADE
1	521	114.283	138.6	21	-5	2	30	12	48	0
2	522	113.985	138.3	22	11	2	30	12	48	0
3	523	113.691	138.1	23	21	2	30	12	48	0
4	524	113.682	137.7	24	-2	2	30	12	48	0
5	525	113.083	137.4	25	10	2	30	12	48	2
6	526	112.444	137.2	26	8	2	30	12	48	0
7	527	112.320	136.9	27	7	2	30	12	48	0
8	528	112.208	136.6	28	-27	2	30	12	48	0
9	529	112.101	136.3	29	15	2	30	12	48	0
10	530	112.565	136.0	30	6	2	30	12	48	0
11	531	112.800	135.7	31	7	2	30	12	48	0
12	532	113.384	135.3	32	29	2	30	12	48	1
13	533	113.304	135.1	33	4	2	30	12	48	0
14	534	113.415	134.7	34	13	2	30	12	48	0
15	535	113.431	134.5	35	-33	2	30	12	48	0
16	536	113.915	134.4	36	3	2	30	12	48	0
17	537	114.123	134.1	37	6	2	30	12	48	0
18	538	113.989	133.8	38	6	2	30	12	48	0
19	539	113.736	133.4	39	--	2	30	12	48	1
20	540	113.616	133.1	40	6	2	30	12	48	2

FIELD DATA TABLE

SHOT NUMBER 25 SHOT POINT 11 TEAM 4
 SHOT TIME: 317: 6: 6: 0.010

LOC	DIST(KM)	AZIM	UNIT	CHRON	CHAN	C1	C2	C3	TAPE	GRADE
1	551	114.240	129.4	61	14	2	30	12	48	0
2	552	114.381	129.2	62	4	2	30	12	48	0
3	553	114.603	128.8	63	10	2	30	12	48	0
4	554	114.613	128.5	64	12	2	30	12	48	0
5	555	114.621	128.2	65	-11	2	30	12	68	0
6	556	114.491	127.9	66	13	2	30	12	68	0
7	557	114.398	127.6	67	31	2	30	12	68	3
8	558	114.360	127.3	68	1	2	30	12	68	0
9	559	114.210	127.0	69	6	2	30	12	68	0
10	560	113.893	126.8	70	31	2	30	12	88	0
11	561	113.982	126.4	71	39	2	30	12	88	0
12	562	114.113	126.2	72	18	2	30	12	88	0
13	563	114.430	125.9	73	-3	2	30	12	88	0
14	564	114.729	125.6	74	3	2	30	12	88	0
15	565	114.865	125.3	75	15	2	30	12	68	1
16	566	114.962	125.0	76	19	2	30	12	68	0
17	567	115.085	124.7	77	14	2	30	12	68	0
18	568	115.063	124.4	78	10	1	30	12	68	0
19	569	115.360	124.1	79	-7	2	30	12	68	0
20	570	115.529	123.8	80	7	2	30	12	48	0

FIELD DATA TABLE

SHOT NUMBER 26 SHOT POINT 16 TEAM 1
 SHOT TIME: 317: 6: 8: 0.010

LOC	DIST(KM)	AZIM	UNIT	CHRON	CHAN	C1	C2	C3	TAPE	GRADE
1	142	54.277	224.0	1	20	30	12	88	3	
2	502	53.576	224.2	2	17	2	30	12	88	0
3	503	52.836	224.1	3	15	2	30	12	88	0
4	504	52.310	224.1	4	-16	2	30	12	68	0
5	505	51.639	224.0	5	21	2	30	12	68	0
6	506	51.088	223.7	6	6	2	30	12	68	0
7	507	50.575	223.7	7	-7	2	30	12	68	0
8	508	49.871	224.0	8	1	2	30	12	68	0
9	509	49.311	224.1	9	84	2	30	12	48	0
10	510	48.742	223.9	10	116	2	30	12	48	0
11	511	48.270	224.2	11	13	2	30	12	48	0
12	512	47.466	224.1	12	13	30	12	48	2	
13	513	46.935	224.1	13	17	2	30	12	48	0
14	514	46.307	224.3	14	11	2	30	12	48	0
15	515	45.606	224.2	15	13	30	12	48	4	
16	516	45.092	224.3	16	16	30	12	48	1	
17	517	44.555	224.7	17	17	2	30	12	48	0
18	518	43.989	224.7	18	-27	2	30	12	48	0
19	519	43.313	224.6	19	100	2	30	12	48	0
20	520	42.861	224.3	20	39	2	30	12	48	0

FIELD DATA TABLE

SHOT NUMBER 25 SHOT POINT 11 TEAM 5
 SHOT TIME: 317: 6: 6: 0.010

LOC	DIST(KM)	AZIM	UNIT	CHRON	CHAN	C1	C2	C3	TAPE	GRADE
1	591	118.137	117.7	81	13	2	30	12	88	0
2	592	118.223	117.4	82	-7	2	30	12	88	0
3	593	118.239	117.2	83	25	2	30	12	88	0
4	594	118.322	116.9	84	-2	2	30	12	68	0
5	595	118.616	116.6	85	17	2	30	12	68	0
6	596	118.902	116.3	86	-4	2	30	12	68	0
7	597	119.180	116.1	87	-8	2	30	12	68	0
8	598	119.472	115.8	88	21	2	30	12	68	0
9	599	119.306	115.5	89	-4	2	30	12	48	3
10	600	118.954	115.2	90	16	2	30	12	48	0
11	601	118.609	114.8	91	8	2	30	12	48	0
12	602	118.280	114.5	92	0	2	30	12	48	0
13	603	118.153	114.1	93	25	2	30	12	48	0
14	604	118.237	113.8	94	24	2	30	12	48	0
15	605	118.353	113.6	95	9	2	30	12	48	0
16	1	144.058	163.7	96	-8	2	30	12	48	0
17	3	122.692	151.3	97	4	2	30	12	48	0
18	2	128.100	158.4	98	-11	2	30	12	48	0
19	14	162.636	174.3	99	23	1	30	12	48	0
20	12	145.397	96.9	100	10	2	30	12	48	0

FIELD DATA TABLE

SHOT NUMBER 26 SHOT POINT 16 TEAM 2
 SHOT TIME: 317: 6: 8: 0.010

LOC	DIST(KM)	AZIM	UNIT	CHRON	CHAN	C1	C2	C3	TAPE	GRADE	
1	521	42.229	224.0	21	-5	2	30	12	48	0	
2	522	41.555	224.3	22	11	2	30	12	48	0	
3	523	41.098	224.7	23	21	2	30	12	48	0	
4	524	40.389	224.7	24	-2	2	30	12	48	0	
5	525	39.778	225.5	25	10	2	30	12	48	2	
6	526	39.257	226.4	26	8	2	30	12	48	0	
7	527	38.689	226.5	27	7	2	30	12	48	0	
8	528	38.220	226.7	28	-27	2	30	12	48	0	
9	529	37.528	226.8	29	15	2	30	12	48	0	
10	530	37.047	226.1	30	6	2	30	12	48	0	
11	531	36.340	225.7	31	7	2	30	12	48	0	
12	532	35.658	224.8	32	29	4	2	30	12	48	1
13	533	35.138	224.9	33	4	2	30	12	48	0	
14	534	34.453	224.7	34	13	2	30	12	48	0	
15	535	34.072	224.7	35	-33	2	30	12	48	0	
16	536	33.858	223.9	36	3	2	30	12	48	0	
17	537	33.188	223.4	37	6	2	30	12	48	0	
18	538	32.750	223.7	38	6	2	30	12	48	0	
19	539	31.796	224.1	39	--	2	30	12	48	1	
20	540	31.334	224.4	40	6	2	30	12	48	2	

FIELD DATA TABLE

SHOT NUMBER 25 SHOT POINT 11 TEAM 6
 SHOT TIME: 317: 6: 6: 0.010

LOC	DIST(KM)	AZIM	UNIT	CHRON	CHAN	C1	C2	C3	TAPE	GRADE
1	541	113.585	132.8	101	19	2	30	12	68	0
2	542	114.325	132.5	102	7	2	30	12	68	0
3	543	113.698	131.9	103	2	2	30	12	48	0
4	544	113.744	131.5	104	0	2	30	12	48	0
5	545	114.050	131.3	105	21	2	30	12	48	0
6	546	114.140	131.0	106	0	2	30	12	48	0
7	547	114.360	130.6	107	34	2	30	12	48	0
8	548	114.497	130.3	108	15	2	30	12	48	0
9	549	114.598	130.1	109	6	2	30	12	48	0
10	550	114.653	129.8	110	14	2	30	12	48	0
11	606	118.421	113.3	111	69	2	30	12	48	0
12	607	118.514	113.0	112	13	2	30	12	48	0
13	608	118.623	112.7	113	6	2	30	12	68	0
14	609	118.701	112.4	114	8	2	30	12	68	0
15	610	118.793	112.1	115	10	2	30	12	68	0
16	611	118.914	111.8	116	13	2	30	12	68	0
17	612	119.039	111.5	117	22	2	30	12	68	0
18	613	119.135	111.2	118	17	1	30	12	68	0
19	614	119.134	110.9	119	7	2	30	12	68	0
20	615	119.307	110.7	120	4	2	30	12	68	0

FIELD DATA TABLE

SHOT NUMBER 26 SHOT POINT 16 TEAM 5
 SHOT TIME: 317: 6: 8: 0.010

LOC	DIST(KM)	AZIM	UNIT	CHRON	CHAN	C1	C2	C3	TAPE	GRADE
1	591	0.044	348.6	81	13	3	30	12	88	0
2	592	0.627	33.5	82	-7	3	30	12	88	0
3	593	1.225	34.3	83	25	3	30	12	88	0
4	594	1.773	33.0	84	-2	3	30	12	68	0
5	595	2.422	38.5	85	17	3	30	12	68	0
6	596	3.020	41.8	86	-4	3	30	12	68	0
7	597	3.612	43.9	87	-8	3	30	12	68	0
8	598	4.236	45.4	88	21	1	30	12	68	0
9	599	4.800	41.0	89	-4	3	30	12	48	0
10	600	5.433	35.4	90	16	3	30	12	48	3
11	601	6.092	31.1	91	8	3	30	12	48	0
12	602	6.796	27.7	92	0	1	30	12	48	0
13	603	7.455	26.5	93	25	1	30	12	48	0
14	604	8.061	27.0	94	24	1	30	12	48	0
15	605	8.657	27.5	95	9	1	30	12	48	0
16		104.992	218.2	96	-8	2	30	12	48	0
17	3	69.665	221.6	97	4	2	30	12	48	0
18	2	85.944	222.5	98	-11	2	30	12	48	0
19	14	138.718	220.3	99	23	1	30	12	48	0
20	12	54.667	47.3	100	10	2	30	12	48	0

FIELD DATA TABLE

SHOT NUMBER 26 SHOT POINT 16 TEAM 3
 SHOT TIME: 317: 6: 8: 0.010

LOC	DIST(KM)	AZIM	UNIT	CHRON	CHAN	C1	C2	C3	TAPE	GRADE
1	571	12.011	222.9	41	29	2	30	12	48	0
2	572	11.471	217.8	42	11	2	30	12	48	0
3	573	10.820	217.4	43	10	2	30	12	48	0
4	574	10.212	217.0	44	33	2	30	12	48	0
5	575	9.614	217.5	45	-2	2	30	12	48	0
6	576	9.014	218.6	46	29	1	30	12	48	0
7	577	8.398	221.9	47	33	1	30	12	48	0
8	578	7.841	227.1	48	36	2	30	12	48	0
9	579	7.232	226.1	49	15	2	30	12	48	0
10	580	6.606	225.6	50	-18	2	30	12	48	0
11	581	5.993	223.1	51	29	1	30	12	48	0
12	582	5.424	221.8	52	15	1	30	12	48	0
13	583	4.800	221.1	53	11	1	30	12	48	0
14	584	4.206	221.5	54	11	2	30	12	68	0
15	585	3.580	219.2	55	-8	1	30	12	68	0
16	586	2.986	218.8	56	13	1	30	12	68	0
17	587	2.419	224.3	57	32	1	30	12	68	0
18	588	1.896	207.2	58	14	1	30	12	68	0
19	589	1.216	215.4	59	1	1	30	12	88	0
20	590	0.586	219.3	60	-5	1	30	12	88	0

FIELD DATA TABLE

SHOT NUMBER 26 SHOT POINT 16 TEAM 6
 SHOT TIME: 317: 6: 8: 0.010

LOC	DIST(KM)	AZIM	UNIT	CHRON	CHAN	C1	C2	C3	TAPE	GRADE
1	541	30.641	224.4	101	19	2	30	12	68	0
2	542	30.161	223.1	102	7	2	30	12	68	0
3	543	28.832	224.3	103	2	2	30	12	48	0
4	544	28.176	224.3	104	0	2	30	12	48	0
5	545	27.633	223.7	105	21	2	30	12	48	0
6	546	27.019	223.5	106	0	2	30	12	48	0
7	547	26.379	223.1	107	34	2	30	12	48	0
8	548	25.744	222.8	108	15	2	30	12	48	0
9	549	25.295	222.6	109	6	2	30	12	48	0
10	550	24.635	222.6	110	14	2	30	12	48	0
11	606	9.267	27.7	111	69	1	30	12	48	0
12	607	9.880	28.0	112	13	1	30	12	48	0
13	608	10.500	28.4	113	18	1	30	12	68	0
14	609	11.095	28.5	114	6	1	30	12	68	0
15	610	11.701	28.6	115	10	2	30	12	68	0
16	611	12.292	28.9	116	13	2	30	12	68	0
17	612	12.920	29.1	117	22	1	30	12	68	0
18	613	13.516	29.3	118	17	1	30	12	88	0
19	614	14.142	29.2	119	17	2	30	12	88	0
20	615	14.563	29.4	120	4	2	30	12	88	0

FIELD DATA TABLE

SHOT NUMBER 26 SHOT POINT 16 TEAM 4
 SHOT TIME: 317: 6: 8: 0.010

LOC	DIST(KM)	AZIM	UNIT	CHRON	CHAN	C1	C2	C3	TAPE	GRADE
1	551	23.986	223.6	61	14	2	30	12	48	0
2	552	23.408	223.4	62	4	2	30	12	48	0
3	553	22.649	222.9	63	10	2	30	12	48	0
4	554	22.129	223.0	64	12	2	30	12	48	0
5	555	21.469	223.1	65	-11	2	30	12	68	0
6	556	20.942	223.6	66	13	2	30	12	68	0
7	557	20.348	224.0	67	31	2	30	12	68	2
8	558	19.712	224.3	68	1	2	30	12	68	0
9	559	19.199	224.9	69	6	2	30	12	68	0
10	560	18.742	226.1	70	31	2	30	12	88	0
11	561	18.088	226.1	71	39	2	30	12	88	0
12	562	17.544	225.9	72	18	2	30	12	88	0
13	563	16.954	225.2	73	-3	2	30	12	88	0
14	564	16.265	224.5	74	3	2	30	12	88	0
15	565	15.632	224.3	75	15	2	30	12	68	1
16	566	15.028	224.3	76	15	2	30	12	68	0
17	567	14.423	224.2	77	14	2	30	12	68	0
18	568	13.842	224.5	78	10	1	30	12	68	3
19	569	13.209	223.8	79	-7	1	30	12	68	0
20	570	12.617	223.5	80	7	2	30	12	48	0

FIELD DATA TABLE

SHOT NUMBER 27 SHOT POINT 7 TEAM 1
 SHOT TIME: 317: 9: 0: 0.008

LOC	DIST(KM)	AZIM	UNIT	CHRON	CHAN	C1	C2	C3	TAPE	GRADE
1	142	68.432	220.9	1	22	30	12	88	3	0
2	502	67.720	221.1	2	19	30	12	88	0	0
3	503	66.987	221.0	3	16	30	12	88	0	0
4	504	66.463	220.9	4	-18	30	12	68	0	0
5	505	65.797	220.9	5	23	30	12	68	0	0
6	506	65.260	220.6	6	7	30	12	68	0	0
7	507	64.748	220.6	7	-7	30	12	68	0	0
8	508	64.031	220.7	8	1	30	12	68	0	0
9	509	63.468	220.8	9	91	30	12	68	0	0
10	510	62.907	220.6	10	125	2	30	12	48	0
11	511	62.424	220.8	11	15	2	30	12	48	0
12	512	61.627	220.7	12	14	30	12	48	2	0
13	513	61.093	220.7	13	19	2	30	12	48	0
14	514	60.458	220.8	14	12	2	30	12	48	0
15	515	59.761	220.7	15	14	30	12	48	4	0
16	516	59.244	220.7	16	17	30	12	48	1	0
17	517	58.688	221.0	17	18	2	30	12	48	0
18	518	58.123	221.0	18	-29	2	30	12	48	0
19	519	57.457	220.8	19	108	2	30	12	48	0
20	520	57.018	220.6	20	43	2	30	12	48	0

FIELD DATA TABLE

SHOT NUMBER 27 SHOT POINT 7 TEAM 3
 SHOT TIME: 317: 9: 0: 0.008

LOC	DIST(KM)	AZIM	UNIT	CHRON	CHAN	C1	C2	C3	TAPE	GRADE
1	571	26.353	215.5	41	32	1	30	12	48	0
2	572	25.926	213.1	42	12	2	30	12	48	0
3	573	25.285	212.8	43	11	1	30	12	48	0
4	574	24.684	212.5	44	37	1	30	12	48	0
5	575	24.081	212.6	45	-2	1	30	12	48	0
6	576	23.468	212.9	46	33	1	30	12	48	0
7	577	22.796	214.0	47	37	1	30	12	48	0
8	578	22.124	215.6	48	40	1	30	12	48	0
9	579	21.552	215.0	49	17	1	30	12	48	0
10	580	20.950	214.5	50	-20	1	30	12	48	0
11	581	20.397	213.4	51	32	1	30	12	48	0
12	582	19.896	212.8	52	16	1	30	12	48	0
13	583	19.250	212.3	53	12	1	30	12	48	0
14	584	18.659	212.1	54	12	2	30	12	68	0
15	585	18.063	211.3	55	-9	1	30	12	68	0
16	586	17.479	211.0	56	14	1	30	12	68	0
17	587	16.874	211.5	57	35	1	30	12	68	0
18	588	16.420	209.1	58	16	1	30	12	68	0
19	589	15.736	209.9	59	1	1	30	12	88	0
20	590	15.103	209.8	60	-6	1	30	12	88	0

FIELD DATA TABLE

SHOT NUMBER 27 SHOT POINT 7 TEAM 2
 SHOT TIME: 317: 9: 0: 0.008

LOC	DIST(KM)	AZIM	UNIT	CHRON	CHAN	C1	C2	C3	TAPE	GRADE
1	521	56.402	220.3	21	-5	2	30	12	48	0
2	522	55.714	220.5	22	19	2	30	12	48	0
3	523	55.240	220.8	23	23	2	30	12	48	0
4	524	54.536	220.7	24	-2	2	30	12	48	0
5	525	53.885	221.2	25	11	2	30	12	48	2
6	526	53.317	221.9	26	9	2	30	12	48	0
7	527	52.742	221.9	27	9	2	30	12	48	0
8	528	52.266	222.0	28	-29	2	30	12	48	0
9	529	51.563	222.0	29	16	2	30	12	48	2
10	530	51.128	221.5	30	7	2	30	12	48	0
11	531	50.443	221.1	31	9	2	30	12	48	0
12	532	49.810	220.4	32	32	2	30	12	48	1
13	533	49.236	220.4	33	4	2	30	12	48	0
14	534	48.613	220.2	34	14	2	30	12	48	0
15	535	48.234	220.2	35	-36	2	30	12	48	0
16	536	48.058	219.6	36	4	2	30	12	48	0
17	537	47.412	219.2	37	7	2	30	12	48	0
18	538	46.961	219.4	38	7	2	30	12	48	0
19	539	45.991	219.5	39	-	2	30	12	48	1
20	540	45.520	219.7	40	-	2	30	12	48	2

FIELD DATA TABLE

SHOT NUMBER 27 SHOT POINT 7 TEAM 4
 SHOT TIME: 317: 9: 0: 0.008

LOC	DIST(KM)	AZIM	UNIT	CHRON	CHAN	C1	C2	C3	TAPE	GRADE
1	551	38.232	218.3	61	16	1	30	12	48	2
2	552	37.667	218.1	62	4	1	30	12	48	0
3	553	36.927	217.7	63	11	1	30	12	48	0
4	554	36.407	217.6	64	14	1	30	12	48	0
5	555	35.747	217.6	65	-12	1	30	12	68	0
6	556	35.205	217.8	66	14	1	30	12	68	0
7	557	34.599	217.9	67	34	1	30	12	68	2
8	558	33.956	218.0	68	1	1	30	12	68	0
9	559	33.421	218.3	69	6	1	30	12	68	0
10	560	32.922	218.8	70	34	1	30	12	88	0
11	561	32.271	218.7	71	43	2	30	12	88	0
12	562	31.738	218.5	72	20	1	30	12	88	0
13	563	31.182	217.9	73	-3	2	30	12	88	0
14	564	30.524	217.4	74	3	1	30	12	88	0
15	565	29.902	217.2	75	17	1	30	12	68	1
16	566	29.303	217.0	76	21	1	30	12	68	0
17	567	28.707	216.8	77	15	1	30	12	68	0
18	568	28.116	216.9	78	11	1	30	12	68	3
19	569	27.515	216.3	79	-8	1	30	12	68	0
20	570	26.939	216.0	80	8	1	30	12	48	0

FIELD DATA TABLE

SHOT NUMBER 28 SHOT POINT 1 TEAM 1
 SHOT TIME: 317: 9: 2: 0.011

LOC	DIST(KM)	AZIM	UNIT	CHRON	CHAN	C1	C2	C3	TAPE	GRADE
1	51.274	31.8	1	22	2	30	12	88	3	0
2	52.004	31.7	2	19	2	30	12	88	0	0
3	52.707	32.0	3	16	2	30	12	88	0	0
4	53.218	32.1	4	-18	2	30	12	68	0	0
5	53.861	32.3	5	23	2	30	12	68	0	0
6	54.357	32.7	6	7	2	30	12	68	0	0
7	54.861	32.8	7	-7	2	30	12	68	0	0
8	55.599	32.7	8	1	2	30	12	68	0	0
9	56.164	32.7	9	91	2	30	12	48	0	0
10	56.699	32.9	10	123	2	30	12	48	0	0
11	57.199	32.8	11	15	2	30	12	48	0	0
12	57.972	33.1	12	14	2	30	12	48	2	2
13	58.506	33.1	13	19	2	30	12	48	0	0
14	59.150	33.1	14	12	2	30	12	48	0	0
15	59.829	33.2	15	14	2	30	12	48	4	4
16	60.346	33.3	16	17	2	30	12	48	1	1
17	60.934	33.1	17	18	2	30	12	48	0	0
18	61.489	33.2	18	-29	2	30	12	48	0	0
19	62.128	33.4	19	108	2	30	12	48	0	0
20	62.539	33.7	20	43	2	30	12	48	0	0

FIELD DATA TABLE

SHOT NUMBER 27 SHOT POINT 7 TEAM 5
 SHOT TIME: 317: 9: 0: 0.003

LOC	DIST(KM)	AZIM	UNIT	CHRON	CHAN	C1	C2	C3	TAPE	GRADE
1	14.492	209.5	81	15	1	30	12	88	0	0
2	13.901	209.2	92	-8	1	30	12	88	0	0
3	13.306	208.9	83	28	1	30	12	88	0	0
4	12.757	208.9	84	-2	1	30	12	68	0	0
5	12.141	207.6	85	19	1	30	12	68	0	0
6	11.535	206.2	86	-4	1	30	12	68	0	0
7	11.066	204.7	87	-9	1	30	12	68	0	0
8	10.520	203.0	88	23	1	30	12	68	0	0
9	9.872	203.8	89	-4	1	30	12	48	3	3
10	9.142	205.8	90	18	3	30	12	48	0	0
11	8.438	208.1	91	9	3	30	12	48	0	0
12	7.735	210.8	92	0	1	30	12	48	0	0
13	7.030	212.4	93	26	3	30	12	48	0	0
14	6.480	212.4	94	27	3	30	12	48	0	0
15	5.879	212.4	95	10	3	30	12	48	0	0
16	119.365	217.2	96	-9	2	30	12	48	0	0
17	83.917	219.6	97	4	2	30	12	48	0	0
18	100.145	220.6	98	-13	2	30	12	48	0	0
19	153.005	219.3	99	25	1	30	12	48	0	0
20	41.095	33.6	100	12	2	30	12	48	0	0

FIELD DATA TABLE

SHOT NUMBER 28 SHOT POINT 1 TEAM 2
 SHOT TIME: 317: 9: 2: 0.011

LOC	DIST(KM)	AZIM	UNIT	CHRON	CHAN	C1	C2	C3	TAPE	GRADE
1	63.122	34.0	21	-5	2	30	12	48	0	0
2	63.828	33.9	22	13	2	30	12	48	0	0
3	64.324	33.7	23	23	2	30	12	48	0	0
4	65.014	33.8	24	-2	2	30	12	48	0	0
5	65.722	33.5	25	11	2	30	12	48	2	2
6	66.364	33.0	26	9	2	30	12	48	0	0
7	66.942	33.0	27	8	2	30	12	48	0	0
8	67.423	33.0	28	-29	2	30	12	48	0	0
9	68.119	33.1	29	16	2	30	12	48	0	0
10	68.486	33.6	30	7	2	30	12	48	2	2
11	69.128	33.9	31	9	2	30	12	48	0	0
12	69.688	34.5	32	32	2	30	12	48	1	1
13	70.212	34.5	33	5	2	30	12	48	0	0
14	70.867	34.7	34	14	2	30	12	48	0	0
15	71.240	34.7	35	-36	2	30	12	48	0	0
16	71.376	35.2	36	4	2	30	12	48	0	0
17	72.000	35.5	37	7	2	30	12	48	0	0
18	72.459	35.4	38	7	2	30	12	48	0	0
19	73.438	35.3	39	--	2	30	12	48	1	1
20	73.913	35.2	40	7	2	30	12	48	2	2

FIELD DATA TABLE

SHOT NUMBER 27 SHOT POINT 7 TEAM 6
 SHOT TIME: 317: 9: 0: 0.008

LOC	DIST(KM)	AZIM	UNIT	CHRON	CHAN	C1	C2	C3	TAPE	GRADE
1	44.826	219.6	101	21	2	30	12	68	0	0
2	44.408	218.7	102	7	2	30	12	68	0	0
3	43.030	219.4	103	3	1	30	12	48	0	0
4	42.379	219.2	104	-2	1	30	12	48	0	0
5	41.863	218.8	105	23	1	30	12	48	0	0
6	41.256	218.6	106	1	1	30	12	48	0	0
7	40.637	218.3	107	37	1	30	12	48	0	0
8	40.013	218.0	108	16	1	30	12	48	0	0
9	39.574	217.8	109	7	1	30	12	48	0	0
10	38.919	217.7	110	15	1	30	12	48	0	0
11	5.269	212.3	111	76	3	30	12	48	0	0
12	4.654	212.2	112	14	3	30	12	48	0	0
13	4.032	212.0	113	9	1	30	12	68	0	0
14	3.437	212.2	114	7	3	30	12	68	0	0
15	2.830	215.4	115	11	3	30	12	68	0	0
16	2.237	211.8	116	14	3	30	12	68	0	0
17	1.607	211.3	117	24	3	30	12	68	0	0
18	1.010	210.8	118	19	3	30	12	68	0	0
19	0.388	216.8	119	7	3	30	12	68	0	0
20	0.032	39.3	120	5	3	30	12	88	0	0

FIELD DATA TABLE

SHOT NUMBER 28 SHOT POINT 1 TEAM 5
SHOT TIME: 317: 9: 2: 0.011

LOC	DIST(KM)	AZIM	UNIT	CHRON	CHAN	C1	C2	C3	TAPE	GRADE
1	591	105.021	81	15	2	30	12	88	0	0
2	592	105.617	82	-8	2	30	12	88	0	0
3	593	106.215	83	28	2	30	12	88	0	0
4	594	106.758	84	-2	2	30	12	68	0	0
5	595	107.413	85	19	2	30	12	68	0	0
6	596	108.006	86	-4	2	30	12	68	0	0
7	597	108.587	87	-9	2	30	12	68	0	0
8	598	109.196	88	23	2	30	12	68	0	0
9	599	109.787	89	-4	2	30	12	48	0	0
10	600	110.419	90	18	2	30	12	48	3	3
11	601	111.040	91	9	2	30	12	48	0	0
12	602	111.681	92	0	2	30	12	48	0	0
13	603	112.302	93	28	2	30	12	48	0	0
14	604	112.909	94	27	2	30	12	48	0	0
15	605	113.510	95	10	2	30	12	48	0	0
16	1	0.000	96	-9	2	30	12	48	3	3
17	3	35.686	97	4	1	30	12	48	0	0
18	2	20.310	98	-13	2	30	12	48	0	0
19	14	34.006	99	26	1	30	12	48	0	0
20	12	159.207	100	12	2	30	12	48	0	0

FIELD DATA TABLE

SHOT NUMBER 28 SHOT POINT 1 TEAM 3
SHOT TIME: 317: 9: 2: 0.011

LOC	DIST(KM)	AZIM	UNIT	CHRON	CHAN	C1	C2	C3	TAPE	GRADE
1	571	93.027	37.2	41	32	2	30	12	48	0
2	572	93.522	37.9	42	12	2	30	12	48	0
3	573	94.173	37.9	43	11	2	30	12	48	0
4	574	94.783	38.0	44	37	2	30	12	48	0
5	575	95.379	37.9	45	-2	2	30	12	48	0
6	576	95.978	37.8	46	33	2	30	12	48	0
7	577	96.613	37.5	47	37	2	30	12	48	0
8	578	97.252	37.1	48	40	2	30	12	48	0
9	579	97.833	37.2	49	17	1	30	12	48	0
10	580	98.444	37.3	50	-20	2	30	12	48	0
11	581	99.022	37.5	51	33	2	30	12	48	0
12	582	99.580	37.6	52	16	2	30	12	48	0
13	583	100.199	37.7	53	12	2	30	12	48	0
14	584	100.793	37.7	54	12	2	30	12	68	0
15	585	101.412	37.8	55	-9	2	30	12	68	0
16	586	102.006	37.8	56	14	2	30	12	68	0
17	587	102.587	37.7	57	35	2	30	12	68	0
18	588	103.132	38.0	58	16	2	30	12	68	0
19	589	103.777	37.9	59	1	2	30	12	88	0
20	590	104.406	37.8	60	-6	2	30	12	88	0

FIELD DATA TABLE

SHOT NUMBER 2C SHOT POINT 1 TEAM 4
SHOT TIME: 317: 9: 2: 0.011

LOC	DIST(KM)	AZIM	UNIT	CHRON	CHAN	C1	C2	C3	TAPE	GRADE
1	551	81.144	36.2	61	16	2	30	12	48	0
2	552	81.704	36.4	62	4	2	30	12	48	0
3	553	82.440	36.5	63	11	2	30	12	48	0
4	554	82.960	36.6	64	14	2	30	12	48	0
5	555	83.619	36.6	65	-12	1	30	12	68	0
6	556	84.163	36.5	66	14	2	30	12	68	0
7	557	84.770	36.5	67	34	2	30	12	68	2
8	558	85.414	36.4	68	1	2	30	12	68	0
9	559	85.932	36.3	69	6	2	30	12	68	0
10	560	86.462	36.1	70	34	2	30	12	88	0
11	561	87.109	36.2	71	43	2	30	12	88	3
12	562	87.638	36.3	72	20	2	30	12	88	0
13	563	88.187	36.5	73	-3	2	30	12	88	0
14	564	88.841	36.7	74	3	2	30	12	88	0
15	565	89.463	36.8	75	17	2	30	12	68	1
16	566	90.062	36.8	76	21	2	30	12	68	0
17	567	90.659	36.9	77	15	2	30	12	68	3
18	568	91.250	36.9	78	11	2	30	12	68	0
19	569	91.855	37.0	79	-8	1	30	12	68	0
20	570	92.435	37.1	80	8	2	30	12	48	0

FIELD DATA TABLE

SHOT NUMBER 28 SHOT POINT 1 TEAM 6
SHOT TIME: 317: 9: 2: 0.011

LOC	DIST(KM)	AZIM	UNIT	CHRON	CHAN	C1	C2	C3	TAPE	GRADE
1	541	74.605	35.3	101	21	2	30	12	68	0
2	542	74.980	35.9	102	7	2	30	12	68	0
3	543	76.383	35.5	103	3	2	30	12	48	0
4	544	77.028	35.6	104	-2	2	30	12	48	0
5	545	77.528	35.9	105	23	2	30	12	48	0
6	546	78.128	36.0	106	1	2	30	12	48	0
7	547	78.739	36.2	107	37	2	30	12	48	0
8	548	79.358	36.3	108	16	2	30	12	48	0
9	549	79.796	36.4	109	7	2	30	12	48	0
10	550	80.449	36.5	110	15	2	30	12	48	0
11	606	114.116	37.0	111	76	2	30	12	48	0
12	607	114.730	37.0	112	14	2	30	12	48	0
13	608	115.350	36.9	113	9	2	30	12	68	0
14	609	115.942	36.9	114	7	2	30	12	68	0
15	610	116.546	36.9	115	11	2	30	12	68	0
16	611	117.139	36.9	116	14	2	30	12	68	0
17	612	117.767	36.8	117	24	2	30	12	68	0
18	613	118.362	36.8	118	19	1	30	12	68	0
19	614	118.978	36.8	119	7	2	30	12	88	0
20	615	119.403	36.9	120	5	2	30	12	88	0

FIELD DATA TABLE

SHOT NUMBER 29 SHOT POINT 4 TEAM 3
 SHOT TIME: 317: 9: 4: 0.010

LOC	DIST(KM)	AZIM	UNIT	CHRON	CHAN	C1	C2	C3	TAPE	GRADE
1	571	42.130	41	32	2	30	12	48	0	0
2	572	42.752	42	12	2	30	12	48	0	0
3	573	43.408	43	11	2	30	12	48	0	0
4	574	44.021	44	37	2	30	12	48	0	0
5	575	44.600	45	-2	2	30	12	48	0	0
6	576	45.172	46	33	2	30	12	48	0	0
7	577	45.747	47	37	2	30	12	48	0	0
8	578	46.310	48	40	2	30	12	48	0	0
9	579	46.912	49	17	2	30	12	48	0	0
10	580	47.535	50	-20	2	30	12	48	0	0
11	581	48.146	51	33	2	30	12	48	0	0
12	582	48.718	52	16	2	30	12	48	0	0
13	583	49.345	53	13	2	30	12	48	0	0
14	584	49.936	54	12	2	30	12	68	0	0
15	585	50.572	55	-9	2	30	12	68	0	0
16	586	51.165	56	14	2	30	12	68	0	0
17	587	51.719	57	35	2	30	12	68	0	0
18	588	52.327	58	16	2	30	12	68	0	0
19	589	52.936	59	1	2	30	12	88	0	0
20	590	53.534	60	-6	2	30	12	88	0	0

FIELD DATA TABLE

SHOT NUMBER 29 SHOT POINT 4 TEAM 1
 SHOT TIME: 317: 9: 4: 0.010

LOC	DIST(KM)	AZIM	UNIT	CHRON	CHAN	C1	C2	C3	TAPE	GRADE
1	142	0.146	205.5	1	22	30	12	88	3	3
2	502	0.586	27.3	2	19	3	30	12	88	0
3	503	1.304	41.3	3	16	3	30	12	88	0
4	504	1.829	42.5	4	-18	3	30	12	68	0
5	505	2.492	44.6	5	23	3	30	12	68	0
6	506	3.063	48.8	6	7	3	30	12	68	0
7	507	3.573	48.0	7	-7	1	30	12	68	0
8	508	4.268	44.0	8	1	1	30	12	68	0
9	509	4.828	43.1	9	91	3	30	12	48	0
10	510	5.396	44.5	10	125	3	30	12	48	0
11	511	5.870	42.5	11	15	3	30	12	48	0
12	512	6.672	43.4	12	14	3	30	12	48	0
13	513	7.204	43.0	13	19	3	30	12	48	0
14	514	7.835	42.0	14	12	3	30	12	48	0
15	515	8.534	42.5	15	14	3	30	12	48	0
16	516	9.050	42.2	16	17	3	30	12	48	1
17	517	9.603	40.4	17	18	1	30	12	48	0
18	518	10.168	40.6	18	-22	1	30	12	48	0
19	519	10.835	41.5	19	108	1	30	12	48	0
20	520	11.280	42.6	20	43	1	30	12	48	0

FIELD DATA TABLE

SHOT NUMBER 29 SHOT POINT 4 TEAM 2
 SHOT TIME: 317: 9: 4: 0.010

LOC	DIST(KM)	AZIM	UNIT	CHRON	CHAN	C1	C2	C3	TAPE	GRADE
1	521	11.909	43.8	21	-5	1	30	12	48	1
2	522	12.586	42.7	22	13	1	30	12	48	0
3	523	13.052	41.6	23	23	1	30	12	48	0
4	524	13.759	41.9	24	-2	1	30	12	48	0
5	525	14.408	39.8	25	11	30	12	48	2	2
6	526	15.002	37.6	26	9	1	30	12	48	0
7	527	15.580	37.5	27	8	1	30	12	48	0
8	528	16.060	37.4	28	-29	1	30	12	48	0
9	529	16.758	37.4	29	16	1	30	12	48	0
10	530	17.171	39.2	30	7	30	12	48	2	2
11	531	17.849	40.2	31	9	1	30	12	48	0
12	532	18.490	42.3	32	32	30	12	48	1	1
13	533	19.013	42.1	33	5	1	30	12	48	0
14	534	19.692	42.5	34	14	2	30	12	48	0
15	535	20.073	42.6	35	-36	1	30	12	48	0
16	536	20.281	44.0	36	-4	1	30	12	48	0
17	537	20.955	44.8	37	7	1	30	12	48	0
18	538	21.383	44.2	38	7	2	30	12	48	0
19	539	22.342	43.6	39	--	1	30	12	48	1
20	540	22.805	43.3	40	7	30	12	48	2	2

FIELD DATA TABLE

SHOT NUMBER 29 SHOT POINT 4 TEAM 4
 SHOT TIME: 317: 9: 4: 0.010

LOC	DIST(KM)	AZIM	UNIT	CHRON	CHAN	C1	C2	C3	TAPE	GRADE
1	531	30.194	44.1	61	16	2	30	12	48	0
2	532	30.733	44.3	62	4	2	30	12	48	0
3	533	31.496	44.6	63	11	2	30	12	48	0
4	534	32.015	44.5	64	14	2	30	12	48	0
5	535	32.673	44.4	65	-12	1	30	12	68	0
6	536	33.198	44.1	66	14	2	30	12	68	0
7	537	33.790	43.8	67	34	2	30	12	68	2
8	538	34.426	43.6	68	1	2	30	12	68	0
9	539	34.943	43.3	69	6	2	30	12	68	0
10	560	35.414	42.7	70	34	2	30	12	88	0
11	561	36.068	42.7	71	43	2	30	12	88	0
12	562	36.609	42.9	72	20	2	30	12	88	3
13	563	37.189	43.2	73	-3	2	30	12	88	0
14	564	37.874	43.6	74	3	30	12	88	2	2
15	565	38.506	43.6	75	17	2	30	12	68	1
16	566	39.110	43.7	76	21	2	30	12	68	0
17	567	39.715	43.7	77	15	2	30	12	68	0
18	568	40.298	43.6	78	11	2	30	12	68	3
19	569	40.929	43.8	79	-8	2	30	12	68	0
20	570	41.521	43.9	80	8	2	30	12	48	0

FIELD DATA TABLE

SHOT NUMBER 29 SHOT POINT 4 TEAM 5
 SHOT TIME: 317: 9: 4: 0.010

LOC	DIST(KM)	AZIM	UNIT	CHRON	CHAN	C1	C2	C3	TAPE	GRADE
1	591	54.163	43.7	61	15	2	30	12 88	0	0
2	592	54.755	43.7	82	-8	2	30	12 88	0	0
3	593	55.346	43.6	83	28	2	30	12 88	0	0
4	594	55.880	43.4	84	-2	2	30	12 68	0	0
5	595	56.549	43.5	85	19	2	30	12 68	0	0
6	596	57.156	43.7	86	-4	2	30	12 68	0	0
7	597	57.750	43.8	87	-9	2	30	12 68	0	0
8	598	58.373	43.9	88	23	2	30	12 68	0	0
9	599	58.932	43.5	89	-4	2	30	12 48	0	0
10	600	59.516	43.0	90	18	2	30	12 48	3	3
11	601	60.092	42.5	91	9	2	30	12 48	0	0
12	602	60.692	42.0	92	0	2	30	12 48	0	0
13	603	61.289	41.7	93	28	2	30	12 48	0	0
14	604	61.890	41.6	94	27	2	30	12 48	0	0
15	605	62.488	41.5	95	10	2	30	12 48	0	0
16	1	51.420	211.9	96	-9	2	30	12 48	0	0
17	3	15.738	213.1	97	4	1	30	12 48	0	0
18	2	31.858	219.6	98	-13	2	30	12 48	0	0
19	14	84.766	217.7	99	26	1	30	12 48	0	0
20	12	108.760	45.4	100	12	2	30	12 48	0	0

FIELD DATA TABLE

SHOT NUMBER 30 SHOT POINT 6 TEAM 1
 SHOT TIME: 317: 9: 8: 0.010

LOC	DIST(KM)	AZIM	UNIT	CHRON	CHAN	C1	C2	C3	TAPE	GRADE
1	142	36.709	222.9	1	22	30	12 88	3	3	3
2	502	36.005	223.2	2	19	2	30	12 88	0	0
3	503	35.266	223.0	3	16	2	30	12 88	0	0
4	504	34.741	223.0	4	-18	2	30	12 68	0	0
5	505	34.072	222.9	5	23	2	30	12 68	0	0
6	506	33.525	222.4	6	7	2	30	12 68	0	0
7	507	33.013	222.4	7	-7	2	30	12 68	0	0
8	508	32.303	222.8	8	1	2	30	12 68	0	0
9	509	31.742	223.0	9	91	2	30	12 48	0	0
10	510	31.176	222.7	10	126	2	30	12 48	0	0
11	511	30.701	223.1	11	15	2	30	12 48	0	0
12	512	29.898	222.9	12	14	2	30	12 48	2	2
13	513	29.366	222.9	13	19	2	30	12 48	0	0
14	514	28.736	223.2	14	12	2	30	12 48	0	0
15	515	28.035	223.1	15	14	2	30	12 48	4	4
16	516	27.520	223.2	16	17	2	30	12 48	1	1
17	517	26.978	223.9	17	18	2	30	12 48	0	0
18	518	26.413	223.8	18	-29	2	30	12 48	0	0
19	519	25.739	223.5	19	108	2	30	12 48	0	0
20	520	25.290	223.1	20	43	2	30	12 48	0	0

FIELD DATA TABLE

SHOT NUMBER 29 SHOT POINT 4 TEAM 6
 SHOT TIME: 317: 9: 4: 0.010

LOC	DIST(KM)	AZIM	UNIT	CHRON	CHAN	C1	C2	C3	TAPE	GRADE
1	541	23.499	43.2	101	21	1	30	12 68	0	0
2	542	23.986	45.0	102	7	1	30	12 68	0	0
3	543	25.307	43.4	103	3	1	30	12 48	0	0
4	544	25.962	43.5	104	-2	1	30	12 48	0	0
5	545	26.506	44.1	105	23	2	30	12 48	0	0
6	546	27.122	44.3	106	1	2	30	12 48	0	0
7	547	27.765	44.6	107	37	2	30	12 48	0	0
8	548	28.404	44.8	108	17	2	30	12 48	0	0
9	549	28.856	45.0	109	7	2	30	12 48	0	0
10	550	29.517	45.0	110	15	1	30	12 48	0	0
11	606	63.087	41.4	111	76	1	30	12 48	0	0
12	607	63.695	41.3	112	14	2	30	12 48	0	0
13	608	64.311	41.3	113	19	2	30	12 68	0	0
14	609	64.896	41.2	114	7	2	30	12 68	0	0
15	610	65.494	41.1	115	11	2	30	12 68	0	0
16	611	66.084	41.0	116	14	2	30	12 68	0	0
17	612	66.707	40.9	117	24	2	30	12 68	0	0
18	613	67.296	40.8	118	13	1	30	12 88	0	0
19	614	67.904	40.7	119	7	2	30	12 68	0	0
20	615	68.323	40.7	120	5	2	30	12 68	0	0

FIELD DATA TABLE

SHOT NUMBER 30 SHOT POINT 6 TEAM 2
 SHOT TIME: 317: 9: 8: 0.010

LOC	DIST(KM)	AZIM	UNIT	CHRON	CHAN	C1	C2	C3	TAPE	GRADE
1	521	24.663	222.5	21	-5	2	30	12 48	0	0
2	522	23.984	223.1	22	13	2	30	12 48	0	0
3	523	23.522	223.7	23	23	2	30	12 48	0	0
4	524	22.814	223.6	24	-2	2	30	12 48	0	0
5	525	22.195	225.0	25	11	2	30	12 48	2	2
6	526	21.673	226.6	26	9	2	30	12 48	0	0
7	527	21.107	226.9	27	8	2	30	12 48	0	0
8	528	20.639	227.2	28	-29	1	30	12 48	0	0
9	529	19.948	227.5	29	16	1	30	12 48	0	0
10	530	19.463	226.2	30	7	2	30	12 48	2	2
11	531	18.757	225.5	31	9	2	30	12 48	0	0
12	532	18.082	223.6	32	32	2	30	12 48	1	1
13	533	17.560	223.8	33	5	2	30	12 48	0	0
14	534	16.878	223.3	34	14	1	30	12 48	0	0
15	535	16.497	223.2	35	-37	2	30	12 48	0	0
16	536	16.298	222.5	36	4	1	30	12 48	0	0
17	537	15.642	220.4	37	7	1	30	12 48	0	0
18	538	15.196	221.0	38	7	2	30	12 48	0	0
19	539	14.233	221.8	39	-	-	30	12 48	1	1
20	540	13.766	222.2	40	7	2	30	12 48	2	2

FIELD DATA TABLE

SHOT NUMBER 30 SHOT POINT 6 TEAM 5
 SHOT TIME: 317: 9: 8: 0.010

LOC	DIST(KM)	AZIM	UNIT	CHRON	CHAN	C1	C2	C3	TAPE	GRADE
1	591	17.608	45.8	81	15	2	30	12	88	0
2	592	18.196	45.5	82	-8	1	30	12	88	0
3	593	18.786	45.1	83	28	2	30	12	88	0
4	594	19.316	44.7	84	-2	1	30	12	88	0
5	595	19.987	45.0	85	19	2	30	12	68	0
6	596	20.597	45.3	86	-4	2	30	12	68	0
7	597	21.193	45.5	87	-9	1	30	12	68	0
8	598	21.820	45.8	88	23	1	30	12	68	0
9	599	22.370	44.8	89	-4	2	30	12	48	0
10	600	22.947	43.4	90	18	1	30	12	48	3
11	601	23.524	42.1	91	9	1	30	12	48	0
12	602	24.132	40.8	92	0	1	30	12	48	0
13	603	24.738	40.1	93	28	2	30	12	48	0
14	604	25.341	39.9	94	27	2	30	12	48	0
15	605	25.942	39.8	95	10	2	30	12	48	0
16	1	87.601	216.6	96	-9	2	30	12	48	0
17	3	52.150	220.1	97	4	2	30	12	48	0
18	2	68.401	221.5	98	-13	2	30	12	48	0
19	14	121.233	219.4	99	26	1	30	12	48	0
20	12	72.247	46.9	100	12	2	30	12	48	0

FIELD DATA TABLE

SHOT NUMBER 30 SHOT POINT 6 TEAM 3
 SHOT TIME: 317: 9: 8: 0.010

LOC	DIST(KM)	AZIM	UNIT	CHRON	CHAN	C1	C2	C3	TAPE	GRADE
1	571	5.626	52.4	41	32	1	30	12	48	0
2	572	6.436	60.5	42	12	1	30	12	48	0
3	573	7.070	59.1	43	11	1	30	12	48	0
4	574	7.666	57.9	44	37	1	30	12	48	0
5	575	8.199	55.9	45	-2	1	30	12	48	0
6	576	8.722	53.5	46	33	1	30	12	48	0
7	577	9.226	49.6	47	37	1	30	12	48	0
8	578	9.745	45.0	48	40	1	30	12	48	0
9	579	10.352	45.8	49	17	1	30	12	48	0
10	580	10.978	46.1	50	-20	2	30	12	48	0
11	581	11.602	47.4	51	33	1	30	12	48	0
12	582	12.180	47.7	52	16	1	30	12	48	0
13	583	12.808	47.7	53	13	2	30	12	48	0
14	584	13.394	47.3	54	12	2	30	12	68	0
15	585	14.035	47.6	55	-9	1	30	12	68	0
16	586	14.626	47.4	56	15	1	30	12	68	0
17	587	15.166	46.2	57	35	1	30	12	68	0
18	588	15.801	48.1	58	16	1	30	12	68	0
19	589	16.390	46.7	59	1	1	30	12	88	0
20	590	17.002	46.1	60	-6	2	30	12	88	0

FIELD DATA TABLE

SHOT NUMBER 30 SHOT POINT 6 TEAM 6
 SHOT TIME: 317: 9: 8: 0.010

LOC	DIST(KM)	AZIM	UNIT	CHRON	CHAN	C1	C2	C3	TAPE	GRADE
1	541	13.072	222.3	101	22	1	30	12	68	0
2	542	12.633	218.9	102	7	2	30	12	68	0
3	543	11.267	221.6	103	3	1	30	12	48	0
4	544	10.614	221.3	104	-2	1	30	12	48	0
5	545	10.089	219.6	105	23	1	30	12	48	0
6	546	9.481	218.9	106	1	1	30	12	48	0
7	547	8.862	217.3	107	38	1	30	12	48	0
8	548	8.243	216.1	108	17	1	30	12	48	0
9	549	7.808	215.0	109	7	3	30	12	48	0
10	550	7.159	214.1	110	15	3	30	12	48	0
11	606	26.544	39.6	111	76	2	30	12	48	0
12	607	27.154	39.5	112	14	2	30	12	48	0
13	608	27.773	39.3	113	9	2	30	12	68	0
14	609	28.362	39.1	114	7	2	30	12	68	0
15	610	28.964	39.0	115	11	2	30	12	68	0
16	611	29.556	38.9	116	14	2	30	12	68	0
17	612	30.182	38.8	117	24	1	30	12	68	0
18	613	30.775	38.6	118	19	1	30	12	88	0
19	614	31.388	38.4	119	7	1	30	12	88	0
20	615	31.814	38.4	120	5	2	30	12	88	0

FIELD DATA TABLE

SHOT NUMBER 30 SHOT POINT 6 TEAM 4
 SHOT TIME: 317: 9: 8: 0.010

LOC	DIST(KM)	AZIM	UNIT	CHRON	CHAN	C1	C2	C3	TAPE	GRADE
1	551	6.457	217.1	61	16	1	30	12	48	0
2	552	5.897	215.5	62	4	1	30	12	48	0
3	553	5.175	212.5	63	11	3	30	12	48	0
4	554	4.660	211.6	64	14	3	30	12	48	0
5	555	4.007	210.3	65	-12	1	30	12	68	0
6	556	3.455	211.1	66	14	2	30	12	68	0
7	557	2.842	211.4	67	34	1	30	12	68	2
8	558	2.200	210.4	68	1	2	30	12	68	0
9	559	1.652	213.2	69	6	3	30	12	68	0
10	560	1.159	227.2	70	34	1	30	12	88	0
11	561	0.505	230.0	71	43	3	30	12	88	0
12	562	0.041	60.7	72	20	3	30	12	88	3
13	563	0.674	66.3	73	-3	3	30	12	88	0
14	564	1.389	63.5	74	3	1	30	12	88	0
15	565	2.008	58.8	75	17	3	30	12	68	1
16	566	2.599	55.6	76	21	3	30	12	68	0
17	567	3.200	54.0	77	15	1	30	12	68	3
18	568	3.759	50.8	78	11	1	30	12	68	3
19	569	4.412	52.4	79	-8	1	30	12	68	0
20	570	5.009	52.2	80	8	1	30	12	48	0

APPENDIX B

Archive Tape Data Format

Archive data tapes are written in SEG Y standard format (Barry et al, 1975). Recording density is 1600 bpi, phase encoded (PE). In order to accommodate seismic refraction data, some minor changes have been made to the tape header fields. A complete list of header fields is provided in the card image portion of the reel identification header, shown below:

C 1 REEL IDENTIFICATION HEADER BYTES:
 C 2 3217 -3218 sampling interval (microsecs).
 C 3 3221 -3222 number of samples per trace.
 C 4 3225 -3226 data sample format code.
 C 5 3255 -3256 measurement system (1 = meters; 2 = feet).
 C 6
 C 7
 C 8 TRACE IDENTIFICATION HEADER BYTES:
 C 9 1 - 4 trace sequence number within reel.
 C10 5 - 8 trace sequence number within reel.
 C11 9 - 12 station location number.
 C12 29 - 30 trace ID code (1 = seismic data).
 C13 37 - 40 shotpoint-receiver distance (M).
 C14 41 - 44 station elevation (M).
 C15 45 - 48 shotpoint elevation (M).
 C16 49 - 52 source depth (M).
 C17 69 - 70 scalar to be applied to all elevations.
 C18 71 - 72 scalar to be applies to all coordinates.
 C19 73 - 76 shotpoint coordinate - X.
 C20 77 - 80 shotpoint coordinate - Y.
 C21 81 - 84 receiver coordinate - X.
 C22 85 - 88 receiver coordinate - Y.
 C23 89 - 90 coordinate units (1 = meters; 2 = seconds of arc).
 C24 115 - 116 number of sdamples in this trace.
 C25 117 - 118 sample interval in microseconds for this trace.
 C26 121 - 122 instrument attenuation in db.
 C27 157 - 158 shot time - year.
 C28 159 - 160 shot time - day of year.
 C29 161 - 162 shot time - hour of day (24 hour clock).
 C30 163 - 164 shot time - minute of hour.
 C31 165 - 166 shot time - second of minute.
 C32 167 - 168 time basis code (2 = GMT).
 C33 181 - 182 shot time - milliseconds.
 C34 183 - 184 shotpoint location number.
 C35 185 - 186 recording instrument unit number.

C36 191 - 192 distance weighting exponent (hundredths).
C37 193 - 194 shot sequence number (shot number).
C38 195 - 196 shot size (kg).
C39 197 - 200 shot point - station azimuth (second of arc).
C40 201 - 204 time of first point minus shot time (msec).

The data point format is "32 bit floating point", and the appropriate bytes (3225-3226) of the binary reel id header contain a value of 1. The trace amplitudes have not been adjusted for instrument gain, but the gain correction factor can be estimated from the instrument attenuation value (att) specified in bytes 121-122. To correct for gain, the data should be demeaned and then multiplies by:

$$\frac{(att/20)}{10}$$

The measurement system (bytes 3255-3256 of the binary reel header) is set to 1, meters.

Shot point and receiver coordinates are in seconds of arc (byte field 89-90). The coordinate scalar multiplier (bytes 71-72) is set to -100, so the coordinates (bytes 73-88) are in hundredths of a second of arc.

Bytes 157-166 and bytes 181-182 refer to the shot detonation time. The time of the first data sample is found by adding the shot detonation time to the time specified in bytes 201-204.

Since there is no weighting of amplitudes with distance for archive tapes, the distance weighting exponent (bytes 191-192) is not used.

Shot sequence number (bytes 193-194) refers to the order in which shots were fired during the field campaign.